



# CIVL Paragliding Committee

*Fédération  
Aéronautique  
Internationale*

---

## CIVL Competition Class (CCC)

### Paragliders permitted in FAI Category 1 Cross-Country events

2015 Edition

Revision **3.5**

Approved by CIVL Bureau 01 Sept 2014

*Maison du Sport International  
Av. de Rhodanie 54  
CH-1007 Lausanne  
(Switzerland)  
Tél. +41 (0)21 345 10 70  
Fax +41 (0)21 345 10 77  
E-mail: [sec@fai.org](mailto:sec@fai.org)  
Web: [www.fai.org](http://www.fai.org)*

Editor's note: Hang-gliding and paragliding are sports in which both men and women participate. Throughout this document the words "he", "him" or "his" are intended to apply equally to either sex unless it is specifically stated otherwise.

Revision	Changes
3.0	<ol style="list-style-type: none"> <li>1. Included full descriptions of flight and load tests, based on EN 926, to make this a stand-alone document, without references to external standard definitions (which are not publicly available).</li> <li>2. Adjusted references to the test descriptions in section 5.</li> <li>3. Updated riser measurement definition, to make the measurements easier and more reliable.</li> </ol>
3.1	<ol style="list-style-type: none"> <li>1. Included a sample of the way the maximum weight calculations must be performed.</li> <li>2. Updated timeline in section 2.</li> <li>3. Corrected typo in section 3.</li> <li>4. Simplified language in §5.35.</li> </ol>
3.2	Moved weight range requirements from section 5 to section 6. By doing so, CCC wings of different sizes can now be certified and made available for Category 2 events in a staged manner. The requirements for Category 1 events remains identical to the previous edition.
3.3	<ol style="list-style-type: none"> <li>1. Clean-up: Timeline in section 2, fix calculation error in strength test calculation sample</li> <li>2. Adjusted section 1 to reflect all of the changes made during this revision cycle</li> </ol>
3.4	<ol style="list-style-type: none"> <li>1. <a href="#">Approved by CIVL Bureau on 3 June 2014</a></li> <li>2. <a href="#">Some paragraph numbers made more consistent</a></li> </ol>
3.5	<ol style="list-style-type: none"> <li>1. <a href="#">Addition of Annex B</a></li> <li>2. <a href="#">Clean-up and rewriting in sections 2, 3, 5, 7 and 10 to correct or clarify.</a></li> <li>3. <a href="#">Change of deadline in §6.2.i; of tension applied in 7.1 and 7.2; of measure technic in 7.2 Procedure A</a></li> <li>4. <a href="#">Modification of 9.3.2.1 to insure that collapse line structure is similar to the A structure.</a></li> <li>5. <a href="#">Modifications in section 10 to reflect the process and data information defined in Annex B</a></li> <li>6. <a href="#">Modifications in section 11 to reflect the process and data information defined in Annex B</a></li> </ol>

## FEDERATION AERONAUTIQUE INTERNATIONALE

**Maison du Sport International, Av de Rhodanie 54 – CH-1007 LAUSANNE Switzerland**

Copyright 2014

All rights reserved. Copyright in this document is owned by the Fédération Aéronautique Internationale (FAI). Any people acting on behalf of the FAI or one of its Members is hereby authorized to copy, print, and distribute this document, subject to the following conditions:

1. **The document may be used for information only and may not be exploited for commercial purposes.**

**2. Any copy of this document or portion thereof must include this copyright notice.**

Note that any product, process or technology described in the document may be the subject of other Intellectual Property rights reserved by the Fédération Aéronautique Internationale or other entities and is not licensed hereunder.

## Contents

1	Introduction .....	6
1.1	CIVL Competition Class summary.....	6
2	Timing.....	7
3	Goals.....	8
4	Definitions.....	9
4.1	Paraglider .....	9
4.2	Paraglider design, model and size.....	9
4.3	CIVL Competition Class paraglider .....	10
4.4	Paragliders permitted in competitions .....	10
4.5	Additional definitions .....	10
5	Requirements for CIVL Competition Class .....	11
5.1	General .....	11
5.2	Physical requirements .....	11
5.3	In-flight requirements .....	12
5.4	Documentation requirements.....	12
5.5	Certification.....	12
5.6	Marking .....	12
6	Permitted paragliders in FAI Category 1 competitions.....	14
7	Measurement definition for certification .....	15
7.1	Canopy dimension measurements.....	15
7.2	Line attachment point measurements.....	16
7.3	Line length measurements.....	16
7.4	Riser set measurements.....	16
7.5	Canopy shape measurements .....	18
8	Stability test definition for certification.....	20
8.1	Terms and definitions.....	20
8.2	Structural strength tests.....	20
8.3	Line breaking strength test .....	22
8.4	Test report.....	23
9	Flight test definition for certification .....	24
9.1	Terms and definitions.....	24
9.2	Equipment .....	24
9.3	Test specimen.....	25
9.4	Procedure .....	27
9.5	Test manoeuvres .....	29
9.6	Test report.....	36

10	Documentation requirements definition for certification.....	37
10.1	Test report .....	37
10.2	Additional material .....	37
10.3	User’s manual .....	38
11	Measurement definitions for verification in competitions .....	40
11.1	Canopy dimension verification .....	40
11.2	Line attachment point verification .....	40
11.3	Line length verification .....	40
11.4	Riser length verification.....	41
11.5	Line diameters, profiles and internal structure verification .....	41
Appendix A	Maximum weight calculation example .....	42
Appendix B	Excel Template file for measuring gliders .....	44

## 1 Introduction

This document contains the authoritative definition for paragliders permitted to be flown in FAI Category 1 paragliding cross-country events. Its purpose is to serve as a reference for manufacturers, testing laboratories, competition organizers and competition pilots.

Section 2 of the document shows the timeline which will result in the definition coming into effect, and how future revisions will be handled. Section 3 lists the goals that served as the foundation for the definition of the CIVL competition class paragliders. The CIVL competition class itself is defined in sections 4 and 5. Section 6 then specifies the gliders which will be allowed in FAI Category 1 competitions from 2015: Both EN and CIVL competition class certified gliders, as long as they fulfil certain requirements.

Section 7 through 10 describe the measurement and testing and procedures for CIVL Competition Class certification. Section 11 finally gives the measurement and testing procedures for verification during competitions.

### 1.1 *CIVL Competition Class summary*

The CIVL Competition Class definition can be summarized as follows:

1. Use full EN certification (EN 926-1 and EN 926-2) as the basis
2. Additionally restrict top speed by limiting the maximum accelerator effect
3. Additionally restrict aspect ratio to the maximum flat aspect ratio exhibited by EN certified gliders by December 31<sup>st</sup>, 2013
4. Additionally require riser sets which prevent pilots from exceeding the certified top speed
5. Permit line breaking strength tests to be performed for each model size
6. Forego flight tests that are irrelevant to this class of gliders
7. Set the waiting time until pilot input for collapse tests to three seconds
8. Require flight tests to be conducted at the top of a wing's weight range, using a competition harness where relevant
9. Require the user's manual to contain additional information on the paraglider's operation and maintenance
10. Add clear, precise and simple-to-follow measurements and testing procedures to verify a wing's conformity with certification

Additionally, in order to be allowed in an FAI Category 1 event, CIVL Competition Class certified paragliders must be available in multiple sizes, covering a wide range of pilot weight.

## 2 Timing

February 21/22, 2014: The 2014 CIVL Plenary voted on and accepted the proposed CIVL Competition Class definition.

March/April/May, 2014: The CIVL Paragliding Committee made some adjustments to the measurement and testing procedures, as foreseen by the 2014 Plenary. These changes [were approved 3 June 2014](#). The changes served mainly to make the testing easier and more reliable.

[August 2014: Gliders were controlled during the European Championship according to CCC requirements. Adjustments were proposed by the CIVL Paragliding Committee and approved by the Bureau.](#)

January 1, 2015: The definition becomes effective, meaning that CIVL Competition Class certified gliders will be permitted in FAI Category 1 paragliding cross-country competitions if they fulfil the additional weight range requirements defined in section 6 of this document. The definition will be revised every two years from then on. For safety reasons, the CIVL Bureau can approve modifications outside of this regular revision cycle.

Late 2015: Publication of the 2017 edition draft

Early 2016: CIVL Plenary, decision on acceptance of the 2017 edition proposal

January 1, 2017: If accepted by the 2016 Plenary, the revised definition becomes effective

### 3 Goals

The definition of Competition Class paragliders was created with the purpose of World and Continental Championships in mind: safe, fair and satisfying contest flying. This led to the following goals for the class definition:

1. Safety –
  - a. wings complying with this definition are safe to fly by adequately trained competition pilots in competition conditions
  - b. a wing's conformity with certification can be verified by each pilot with a few simple measurements
2. Fairness –
  - a. ensure that wings are available for a wide range of pilot weights
  - b. prevent pilots from gaining an undue advantage over others through temporary or permanent modification of their glider

3. Satisfaction –

Wings complying with this definition provide a satisfactory flying experience to the world's best competition pilots



## 4 Definitions

### 4.1 *Paraglider*

- §4.1 A paraglider is a hang glider as defined by Section 7B of the FAI Sporting Code. Its main components are the canopy, the suspension lines (short “lines”), and two riser sets.
- §4.2 The canopy is the aerodynamic portion of a paraglider, consisting of fabric and other non-rigid elements. Rigid elements may be used to guide brake lines between attachment point and top-most furcation point.
- §4.3 The suspension and brake lines connect the canopy with two riser sets, one for the left half of the canopy, one for the right half of the canopy.
- §4.4 A riser set consists of one or several individual risers, which each connect a subset of the suspension lines to the pilot harness’ main carabiners. A riser set can include an acceleration system.
- §4.5 A riser is typically a piece of webbing fitted with a line attachment point and connected either directly or through additional webbing structure to the pilot harness’ main carabiners.
- §4.6 The acceleration system is typically a pulley system that is operated by the pilot’s legs and modifies individual riser lengths to decrease the canopy’s angle of attack when activated. It is characterised by its maximum travel.

### 4.2 *Paraglider design, model and size*

- §4.7 A paraglider design (short “design”) is characterised by:
- the canopy, including
    - planform, both when laid out flat and its vertical projection when in flight
    - aerodynamic profiles
    - internal structure
    - number and positions of line attachment points
    - materials used for manufacturing
  - the line set, including
    - total number of lines
    - number of furcation points between riser and canopy line attachment points
    - line materials used for manufacturing, not considering line diameter
  - the riser set, including
    - distance of each line attachment point to the main carabiner attachment point
    - lengths and positions of all elements connecting two or more risers, apart from the carabiner attachment point
    - materials used for manufacturing load-carrying parts
  - any other characteristics that are commonly seen as a distinguishing factor between two paraglider designs
- §4.8 A paraglider model (short “model”) is an instance of a paraglider design which exists in one or more sizes, and where those sizes have been obtained by scaling.
- §4.9 A paraglider model size (short “size”) is an instance of a paraglider model, sized for a specific total take-off weight range. It is characterised by
- its canopy dimensions
  - its line dimensions, both length and diameter
  - its acceleration system’s maximum travel
  - its maximum allowed total take-off weight (short “top weight”)
  - its recommended minimum total take-off weight

### **4.3 CIVL Competition Class paraglider**

- §4.10 A CIVL Competition Class paraglider model size is a paraglider model size that is certified to comply with all the certification requirements defined in section 5 of this document.
- §4.11 A CIVL Competition Class paraglider is a paraglider that is identical in all characteristics listed in §4.7 and §4.9 with a Competition Class paraglider model size and which is flown at or below that Competition Class paraglider model size's maximum allowed total take-off weight.

### **4.4 Paragliders permitted in competitions**

- §4.12 To be permitted in FAI Category 1 paragliding cross-country competitions, a paraglider must be in accordance with section 6 of this document.

### **4.5 Additional definitions**

#### **4.5.1 Main lines**

- §4.13 Main lines are lines that are directly connected to the riser set, and connected to the wing either directly or through one or several furcation points.
- §4.14 Main lines are labelled A, B, C, etc. for each span-wise plane of main lines, with the front-most plane in direction of flight being A.
- §4.15 Main lines are numbered 1, 2, 3, etc. for each chord-wise plane of main lines, with the plane closest to the wing's centre being 1.

#### **4.5.2 Main line count**

- §4.16 The main line count of a paraglider canopy's chord-wise row of attachment points is the number of distinct main lines (not counting brake lines) that are connected, either directly or via furcation points, with any of that row's attachment points.
- §4.17 A paraglider model's main line count is given by the maximum main line count across all its chord-wise rows of attachment points.

#### **4.5.3 Line group**

- §4.18 A line group is defined as a set of lines connected to the canopy where all those lines are connected to main lines with the same number (§4.15), either directly or through furcation points.

#### **4.5.4 CIVL accredited testing laboratory**

- §4.19 A CIVL accredited testing laboratory (short "testing laboratory") is an independent testing laboratory qualified for testing paragliders which has performed a minimum of 3 full EN certifications according to EN 926-1 and 926-2 in the twelve months prior to any certification of Competition Class compliance.

## 5 Requirements for CIVL Competition Class

### 5.1 *General*

- §5.1 In order to be certified as a CIVL Competition Class paraglider model size, test specimens of that exact model size must comply with the following set of requirements in its entirety:
- Physical requirements (§5.3 to §5.12)
  - In-flight requirements (§5.13 to §5.14)
  - Documentation requirements (§5.15 to §5.21)
- §5.2 Compliance with the requirements must be verified and certified by a CIVL accredited testing laboratory (§4.19), using the measurement and testing procedures described in sections 7, 8, 9 and 10 of this document.

### 5.2 *Physical requirements*

#### 5.2.1 **Canopy shape**

- §5.3 The flat aspect ratio of the test specimen's canopy, according to the canopy dimension data provided by the manufacturer and verified during the certification process, does not exceed 7.90.
- §5.4 On the centre half (the middle 50% of its span) of the test specimen's canopy, neither the leading edge nor the trailing edge have any concave sections.

#### 5.2.2 **Structural strength**

- §5.5 The test specimen's model size passed the structural strength tests specified in section 8.2. or  
The test specimen has a top weight of no more than 0.8 times the maximum tested weight that resulted from the successful sustained load test defined in section 8.2.4 on another size of the same model that passed the structural strength tests specified in section 8.2.
- §5.6 Any existing EN certification for the test specimen implicitly satisfies the structural strength requirement (§5.5) for the test specimen's model size.

#### 5.2.3 **Line breaking strength**

- §5.7 The test specimen passed the theoretical line breaking strength test specified in section 8.3.
- §5.8 The breaking strength of each line segment used in the test specimen's construction is equal to or higher than the breaking strength of the equivalent line segment subjected to the structural strength tests (§5.5) which cover the test specimen's size.
- §5.9 For a test specimen with existing EN 926-1 certification, to fulfil the line breaking strength requirements (§5.7 and §5.8), individual lines may be replaced with lines of higher breaking strength without repeating the structural strength tests according to §5.5 or the flight tests according to §5.13.

#### 5.2.4 **Riser set layout**

- §5.10 The test specimen's accelerator system, when fully engaged, shortens the front-most riser by 18 cm or less, in relation to the rear-most riser.
- §5.11 The test specimen's riser sets are designed in a way that prevents a change of relative riser lengths beyond the one achieved by maximum acceleration system travel in the acceleration system configuration presented during certification. In particular, it prevents pilots from achieving speeds beyond the certified maximum speed through application of excessive force on the acceleration system, or through temporary modifications of the riser sets.

- §5.12 The only technical means to alter airspeed in flight are the test specimen's brake and acceleration systems. Specifically, there are no trim tabs or any other devices present which can be used to alter airspeed in flight without maintained pilot input.

### **5.3 In-flight requirements**

- §5.13 The test specimen passed the flight tests specified in section 9.
- §5.14 Any existing EN 926-2 certification for the test specimen implicitly satisfies the flight test requirement (§5.13) for the test specimen.

### **5.4 Documentation requirements**

- §5.15 Certification documentation for the test specimen is complete according to section 10.
- §5.16 The test specimen's canopy dimensions correspond with the dimensions documented in the test specimen's user's manual, with a tolerance of +/- 2% for span measurements, and +/- 1% for chord and trailing edge measurements.
- §5.17 If the test specimen has a rib that is marked for the Chord B measurement, that rib is the closest rib towards the canopy centre from the location halfway between the canopy centre and the canopy tip (75% of span).
- §5.18 The line attachment point positions on the test specimen's canopy correspond with the positions documented in the test specimen's user's manual, with a tolerance of +/- 10 mm for chord-wise position, and no tolerance for span-wise position.
- §5.19 The test specimen's line lengths correspond with the lengths documented in the test specimen's user's manual, with a tolerance of +/- 10 mm.
- §5.20 The test specimen's riser lengths, both at trim speed and when fully accelerated, correspond with the lengths documented in the test specimen's user's manual, with a tolerance of +/- 5 mm.
- §5.21 The maximum shortening of the front-most risers relative to the rear-most riser through the accelerator corresponds with the maximum shortening documented in the test specimen's user's manual, with a tolerance of +/- 5 mm.

### **5.5 Certification**

- §5.22 The testing laboratory, after verifying compliance with all requirements, issues a certification of compliance to the manufacturer, and submits a copy of this certification in electronic form to the CIVL [President email: civil-president@fai.org](mailto:civil-president@fai.org).
- §5.23 The testing laboratory provides CIVL with access to the complete test documentation files in electronic form.
- §5.24 The official certification date is the date when the full certification documentation is received by CIVL.

### **5.6 Marking**

- §5.25 The conformity of a paraglider to the requirements of this document must be stated on a stamp or label permanently fixed to the canopy, which must include the following information:
- Manufacturer's name
  - Paraglider model name
  - Paraglider model size indication
  - "CIVL Competition Class", edition of this document (i.e. "2015") and this document's issue date
  - Harness chest strap dimensions (distance between centre of base of connectors) used during flight tests

- f. Year (four digits) and month of manufacture
  - g. Serial number
  - h. Recommended minimum total weight in flight (kg)
  - i. Permitted maximum total weight in flight (top weight)(kg)
  - j. Paraglider weight (canopy, lines and risers)(kg)
  - k. Projected area (m<sup>2</sup>)
  - l. Number of risers
  - m. Maximum shortening of the front-most risers relative to the rear-most riser through the accelerator (mm)
  - n. Inspection periodicity: Number of hours / number of months (“whichever occurs earlier”)
- §5.26 EN-certified paragliders which are also certified CIVL Competition Class must contain the following information on their EN conformity marking, as defined in EN 926-2:2013, section 9: Under g), list “CIVL Competition Class 2015” and this document’s issue date

## 6 Permitted paragliders in FAI Category 1 competitions

- §6.1 Any EN-certified paraglider with classification A, B or C is permitted.
- §6.2 Any EN-certified paraglider with classification D is permitted if at least one of the following applies:
- a. The flat aspect ratio of the paraglider's canopy, as documented in the user's manual, is 7.0 or less.
  - b. The paraglider's model size is listed on CIVL's Web site as fulfilling all of the following criteria:
    - i. The model size was EN certified [in time for the 2014 European Championship](#)
    - ii. The model's canopy fulfils the CIVL Competition Class canopy shape requirements (§5.3 and §5.4)
    - iii. The model has been replaced by a more recent one.
- §6.3 Any CIVL Competition Class certified paraglider is permitted if the following applies:
- a. The difference in top weights between the smallest and the largest CIVL Competition Class certified sizes of the paraglider's model that are commercially available 90 days prior to the start of the competition, is 25 kg or more.
  - b. The smallest CIVL Competition Class certified size of the paraglider's model that is commercially available 90 days prior to the start of the competition, has a top weight of 100 kg or less.

**Note 1:** The intent of the first two paragraphs in this section is to ensure that the introduction of Competition Class does not exclude existing but superseded wings, as has happened under previous rules. It also serves to ensure that pilots are able to participate in competitions flying low-end wings, without any further requirements from manufacturer or pilots.

**Note 2:** From January 1<sup>st</sup>, 2016, the smallest size must have a top weight of 90 kg or less, and the difference between the smallest and the largest size must be 35 kg or more. Additional measures will be defined as necessary to facilitate the creation of CIVL Competition Class paragliders by manufacturers newly entering competitions or returning to competitions after not having produced a high-end EN D competition wing.

## 7 Measurement definition for certification

These measurement and testing procedures must be applied during certification, to establish that a test specimen complies with the certification requirements. The reference for all these measurements is the data given in the test specimen's user's manual. All measurements must yield results that correspond with that reference, within the tolerance given for each measurement.

### 7.1 Canopy dimension measurements

**Results:** Measurements of Span, Chord A, Chord B, Trailing Edge length (see Figure 1)

**Unit:** Millimeter

**Tolerance:** +/- 2% for span measurement; +/- 1% for chord and trailing edge measurement

**Tension:**

- a. Span and Trailing Edge measurements are conducted under tension of 3 daN in the measurement direction
- b. Chord measurements are conducted under tension of 3 daN in the measurement direction

Span is defined as the distance between the two outermost symmetrical attachment points that are closest to the rearmost span-wise internal band, provided that there are no stiffening elements, such as plastic, Mylar or tension tapes, outboard of those points. If there are stiffening elements then the span is measured to the outermost points on them that are closest to the rearmost span-wise internal band.

Trailing Edge length is defined as twice the distance between the outermost, rearmost attachment point and the trailing edge at the centre of the canopy (50% of span, same as rear measurement point for chord A).

Chord is defined by the distance between the trailing edge (held by a clip or sticky tape) and the farthest point on the leading edge (held by hand), without distorting the profile.

Chord A is defined as the chord length along the rib at the canopy centre (50% of span). If no rib is present at the canopy centre, then Chord A is defined as the chord length along the rib closest to the centre of the canopy centre (50% of span).

Chord B is defined as the chord length along the rib that is located halfway between the canopy centre and the canopy tip (75% of span). If no rib is present at the location halfway between canopy centre and the canopy tip, then Chord B is defined as the chord length along the closest rib towards the canopy centre from that location. Manufacturers are encouraged to clearly mark that rib to facilitate verification.

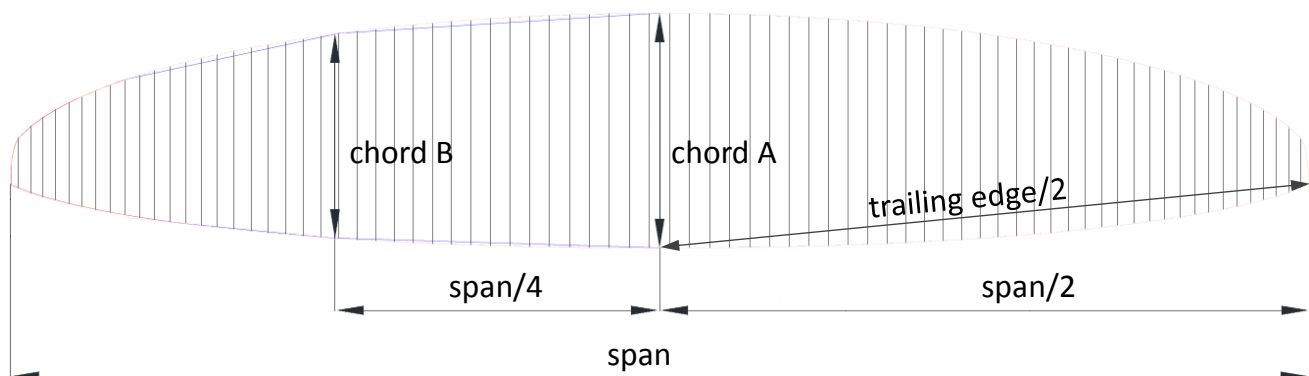

Figure 1: Canopy dimension measurements

## 7.2 *Line attachment point measurements*

### Results:

- a. Exact location of each line attachment points on the test specimen's canopy
- b. Photographic documentation of each different type of line attachment points used on the test specimen's canopy

**Location definition:** An attachment point's location is defined by the rib it is attached to, and its distance from the trailing edge.

**Unit:** span-wise location: rib number (counting from wing centre); chord-wise location: Millimeter

**Tolerance:** none (span-wise); +/- 10 mm (chord-wise)

**Tension:** All measurements are conducted under tension of 3 daN in chord-wise direction

**Procedure A:** For each line attachment point:

1. Record the rib number the attachment point is attached to (counting from the wing's centre)
2. Apply the defined tension to the rib determined in step 1, in chord-wise direction
3. Measure and record the distance from trailing edge to **closest part of** the attachment point along the rib to which the attachment point is connected.

**Procedure B:** For each type of line attachment point (differing in design or construction or materials used) present on the test specimen's canopy: Record a photograph of one specimen, including a scale reference such as a ruler with clearly visible markings.

**Procedure C:** For each brake line attachment point, record the rib number the attachment point is attached to (counting from the wing's centre).

## 7.3 *Line length measurements*

**Results:** Overall suspension line length, as defined by EN 926-2, Annex A, for all attachment points on the canopy

**Unit:** Millimeter

**Tolerance:** +/- 10 mm

**Tension:** All measurements are conducted under tension of 5 daN in the measurement direction

## 7.4 *Riser set measurements*

### 7.4.1 *Trim speed riser measurement*

#### Results:

- a. For each maillon or other line attachment point, the distance between the inside of the maillon loop (the force transfer point between the attachment point and the line loops) and the inside of the main carabiner loop (the force transfer point between main carabiner and main attachment loop) at trim speed. See Figure 2 and Figure 3.
- b. The difference  $\Delta_t$  in riser lengths between front-most and rear-most riser.
- c. Photographic documentation of the riser set in trim configuration

**Unit:** Millimeter

**Tolerance:** +/- 5 mm

**Tension:** All measurements are conducted under tension of 5 daN in measurement direction



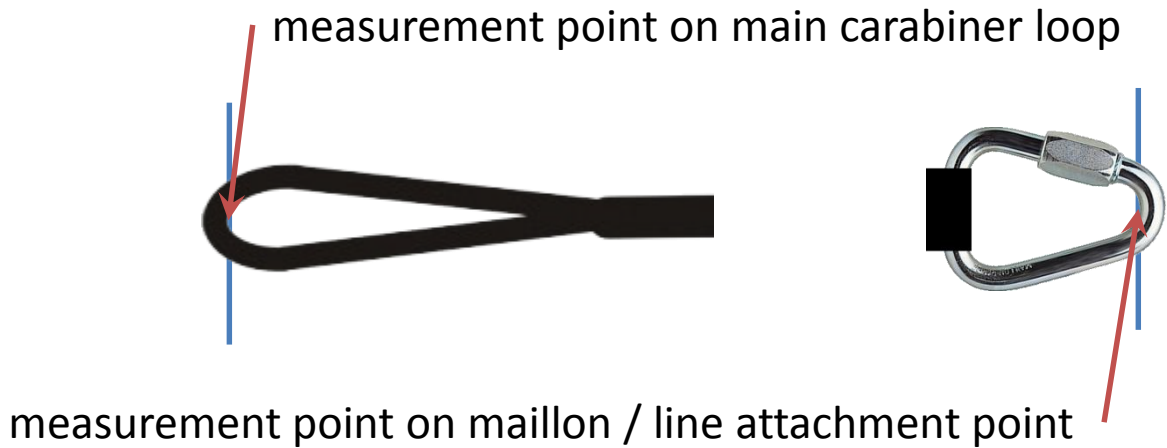

Figure 2: Riser measurement points

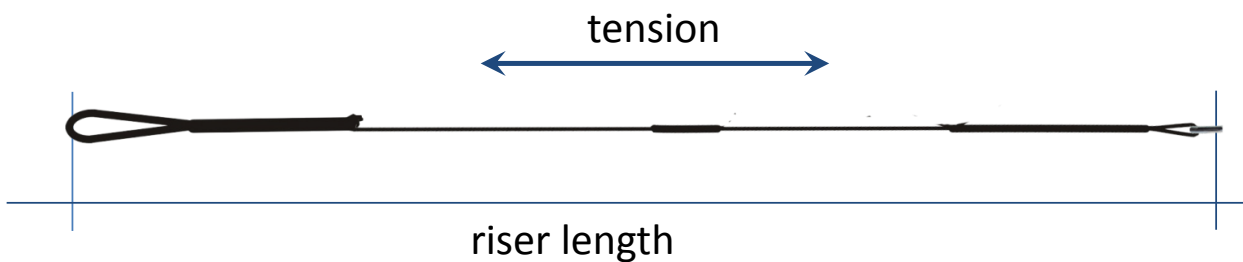

Figure 3: Riser length measurement

**Procedure:**

1. Attach the riser set's main carabiner loop to a fixed point.
2. Apply 5 daN tension to each separate maillon or line attachment point on the riser set. This is done for all maillons or line attachment points at the same time, in the same direction.
3. For each maillon or line attachment point, measure and document the distance between the load-bearing surfaces on the main carabiner loop and the maillon/line attachment point.
4. Calculate the difference in riser-length between front-most ( $l_f$ ) and rear-most ( $l_r$ ) riser:  $\Delta_t = l_r - l_f$ .

**7.4.2 Fully accelerated riser measurement**

**Results:**

- a. For each maillon or other line attachment point, the length difference between the corresponding riser and the front-most riser
- b. The shortening of the front-most riser in relation to the rear-most riser through acceleration
- c. Establish that the riser set is designed in a way that prevents a change of relative riser lengths beyond the one achieved by maximum acceleration system travel in the acceleration system configuration presented during certification
- d. Photographic documentation of the fully accelerated riser set

**Unit:** Millimeter

**Tolerance:** +/- 5 mm

**Tension:** Unless otherwise stated, all measurements are conducted under tension of 5 daN in measurement direction

**Procedure:**

1. Attach the speed system line (or the top pulley if the line is not part of the riser) to a fixed point.

2. Apply 5 daN tension to each separate maillon or line attachment point on the riser set. This is done for all maillons or line attachment points at the same time, in the same direction.
3. Measure the distance  $\Delta_a$  between the front-most and the rear-most maillon or line attachment point. See Figure 4 on the right, in this example,  $\Delta_a$  = distance between B and A1.
4. Calculate the shortening of the front-most riser in relation to the rearmost riser as follows:  
shortening =  $\Delta_t + \Delta_a$

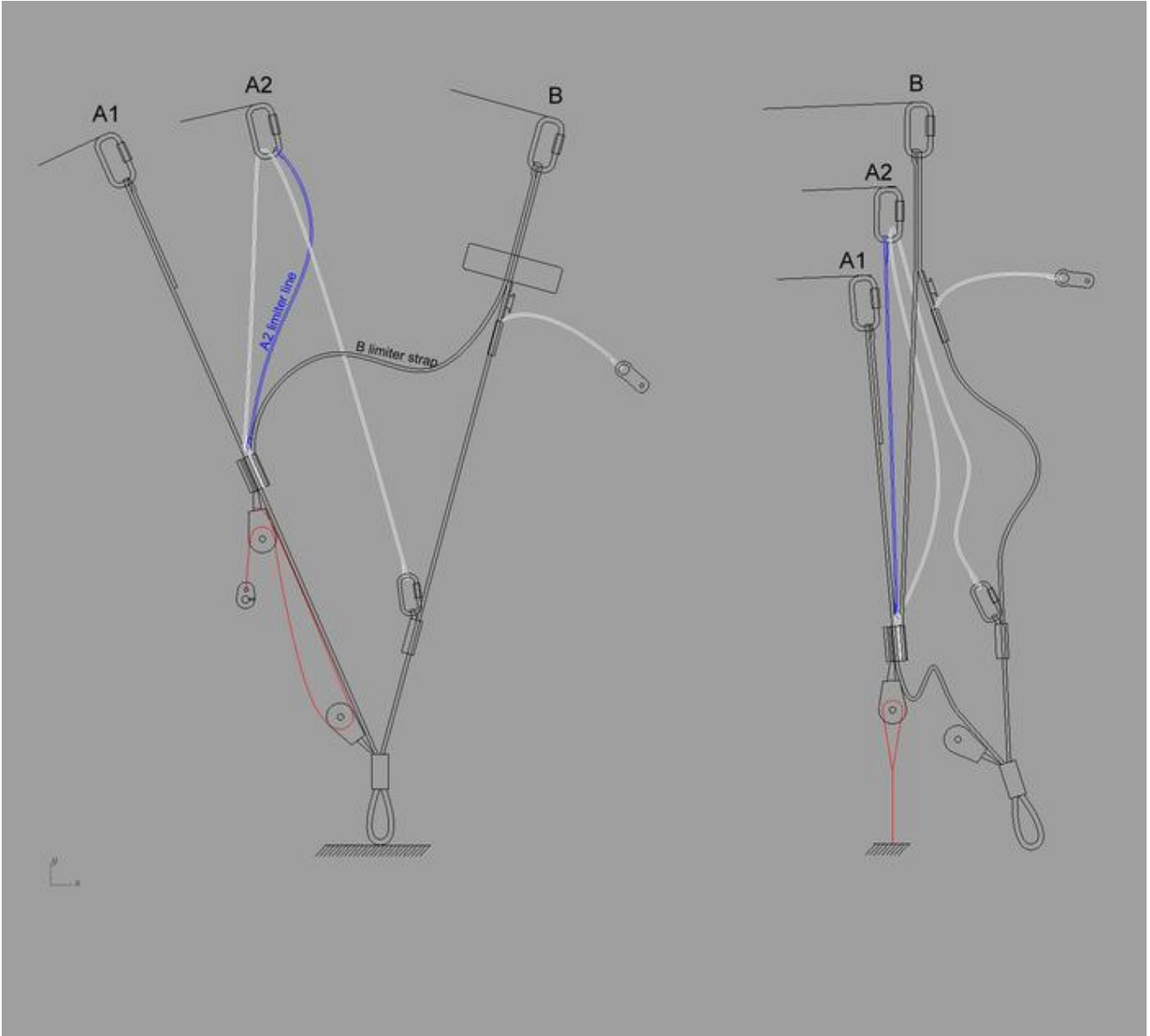

Figure 4: Fully accelerated riser measurement

## 7.5 Canopy shape measurements

### 7.5.1 Flat aspect ratio

**Result:** Approximation of flat aspect ratio ( $AR_{flat}$ )

$$AR_{flat} = \frac{4 * span}{chord(A) + 2.5 * chord(B)}$$

### 7.5.2 Leading and trailing edge shape test

**Results:** Establish that the centre 50% of the canopy's leading and trailing edge do not contain any concave sections.

**Procedure:**

1. Lay out the canopy flat on a flat surface
2. Use a tensioned string or any other straight device of sufficient length to optically mark the connecting line between points  $A_{front}$  and  $B_{front}$  (see Figure 5).
3. The test fails if there is any section where the connecting line between the two points does not run over or exactly alongside the wing (see Figure 6)
4. Repeat for the trailing edge, points  $A_{rear}$  and  $B_{rear}$

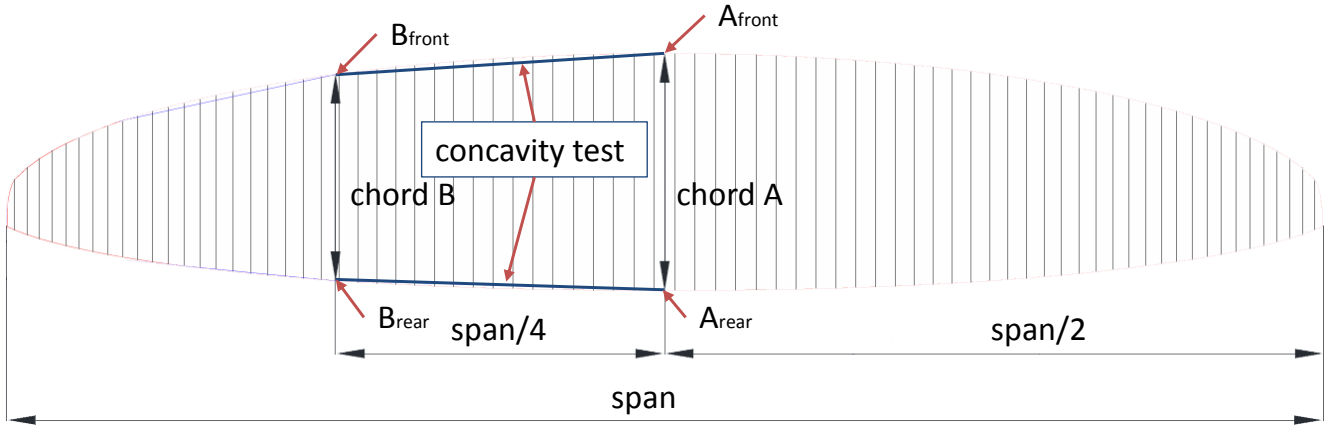

**Figure 5: Position of concavity test**

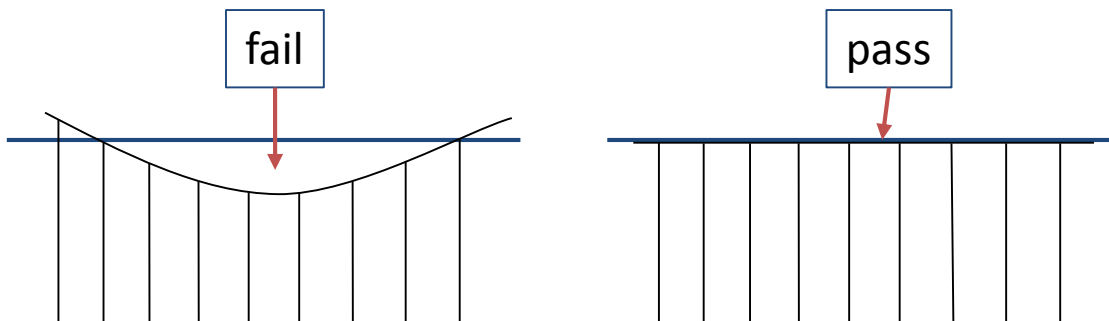

**Figure 6: Detail view of concavity test**

## 8 Stability test definition for certification<sup>1</sup>

### 8.1 Terms and definitions

In the context of this section, the following terms and definitions apply in addition to the general definitions in section 4.

**Identically constructed lines:** lines are identically constructed if the only elements that differ between them are line length and colour.

### 8.2 Structural strength tests

Structural strength of a test specimen is tested through a shock load test (8.2.3) and through a sustained load test (8.2.4).

#### 8.2.1 Equipment

##### 8.2.1.1 Weak link

The weak link used in the shock load test must be calibrated for failure at a load of at least 6.67 times the test specimen's top weight.

##### 8.2.1.2 Cable

The cable used in the shock load test must be a steel cable of 150 m in length, of minimum 6 mm diameter, 18 x 7 all-steel construction, tensile grade 1600 N/mm<sup>2</sup>. The cable may be covered by a non-metallic protective coating.

##### 8.2.1.3 Electronic sensor

The electronic sensor used in the sustained load test must be equipped with an electronic strain gauge for measuring the force. The sampling rate is at least 5 Hz.

##### 8.2.1.4 Measurement circuit

The measurement circuit used in the sustained load test must produce a graph clearly showing the load (in N) against time (in s).

##### 8.2.1.5 Video recording equipment

The video equipment used to document structural strength tests must be mounted on the test vehicle.

#### 8.2.2 Test specimen

The test specimen must be presented ready to fly and conforming in all points to the production model, including production-grade lines (without loops or knots), production-grade riser sets and a user's manual in a language acceptable to the testing laboratory.

#### 8.2.3 Shock load test

##### 8.2.3.1 Principle

The test specimen is subjected to a shock load, and the wing is then visually inspected for damage.

##### 8.2.3.2 Procedure

1. Connect the risers and the control handles to the same point at the weak link specified in 8.2.1.1.
2. Connect one end of the cable specified in 8.2.1.2 to the weak link's free side.
3. Connect the cable's free end to the tow vehicle.

---

<sup>1</sup> This section is based on the EN standard definition EN 926-1.

4. Lay out the cable on the ground so that the test shock load can be applied almost instantaneously.
5. Place the test specimen vertically such that it is supported from close to the leading edge with the trailing edge in the centre touching the ground and the span fully extended. The number of supports must be at least equal to the number of lines in the lowest section of the A lines.
6. Arrange the canopy such as to minimise any slackness (looseness) in the material of the lower surface. The lines and risers must be as straight as possible.
7. The wind speed in the immediate vicinity of the glider must be less than 2 m/s.
8. The tow vehicle accelerates to attain a ground speed of 70 km/h (tolerance +5 km/h / -0 km/h) from the standing start before the cable becomes taut.
9. Continue until either of the following applies:
  - a. the weak link breaks
  - b. the test specimen fails

### **8.2.3.3 Result**

The test specimen fails the shock load test if any damage, such as incipient tears, ruptured suspension lines or deformations, becomes apparent after the test.

## **8.2.4 Sustained load test**

### **8.2.4.1 Principle**

The test specimen is attached to a test vehicle and 'flown' whilst loads are measured. After completion of the sustained loading test, the wing is visually inspected for damage such as incipient tears, ruptured suspension lines or deformations.

### **8.2.4.2 Procedure**

1. Attach the test specimen's riser sets, 0.42 m apart, to the electronic sensors on the tow vehicle.
2. Position a controller on the tow vehicle, to operate the test specimen's control lines to stabilise the wing.
3. Record the test on video from the tow vehicle so as to show the test specimen's behaviour under load.
4. Increase the speed of the vehicle as gradually as possible, enabling the controller to obtain satisfactory stabilisation of the flight path of the test specimen, keeping the load factor less than three times the maximum tested weight, as defined by the manufacturer.
5. When the test specimen has stabilised, continue to increase the speed gradually until either of the following applies:
  - a. The measured load exceeds a load factor of eight times the maximum tested weight, as defined by the manufacturer, for a minimum cumulative duration of 3 s.
  - b. Five peaks separated by at least 0.3 s are obtained above ten times the maximum tested weight, as defined by the manufacturer, in one run.
6. Record the attained maximum tested weight.

### **8.2.4.3 Results**

1. The test specimen fails the shock load test if any damage, such as incipient tears, ruptured suspension lines or deformations, becomes apparent after the test.
2. In the case of a successful test, the result of the sustained load test is the test specimen's maximum tested weight in kg. The test specimen fails the shock load test if this value is less than the test specimen model size's top weight as specified in the user's manual.

## 8.3 Line breaking strength test

### 8.3.1 Principle

The test specimen's top weight is compared with the theoretical breaking strength of the test specimen's complete line system. The theoretical breaking strength is calculated based on the measured breaking strengths of pre-conditioned samples of the line materials actually used for the test specimen.

### 8.3.2 Procedure

**Note:** If identically constructed lines have already been tested, and their breaking strength after pre-conditioning is known, then these previously established values may be used, and steps 1, 2 and 3 of this procedure can be skipped.

1. Obtain three samples of each line type (i.e. three samples of each material and/or processing method) used in test specimen's line system. Each sample must have a length of 0.5 m, with loops on each end.
2. Pre-condition the line samples by bending them  $\pm 180^\circ$  around a cylinder of the same diameter as the line's ( $\pm 0.1$  mm), while under constant tension of 2 N (see Figure 7). The centre point of the bend is to be aligned with the endpoint of the stitching of a line loop (the weakest point of the line). A complete cycle of 2 bending movements takes 2 s. Repeat for 5000 complete bending cycles.

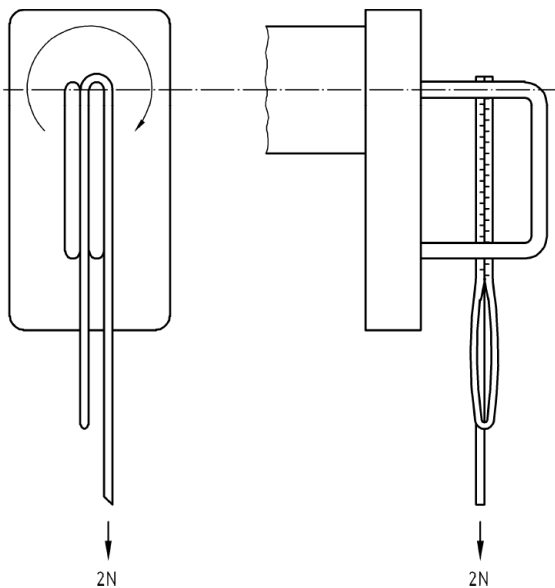

Figure 7: Line pre-conditioning device

3. Measure the pre-conditioned line samples' breaking force. The speed of applying the load must be faster than 0.01666 m/s. For the subsequent calculation,  $F_{break}$  is the lowest value out of the three measurements.
4. Calculate the test specimen's theoretical maximum weight as follows (see also 11.5 Appendix A for an example):

For the lowest line section (the one attached to the risers)

$$W_{max} = \frac{\sum_i F_{break_i} \times n_i}{14g}$$

where

$$g = 9.81 \text{ m/s}^2$$

$F_{break_i}$  is the breaking force of line type  $i$  used in the lowest line section

$n_i$  is the number of lines of line type  $i$  used in the lowest line section

5. For each of the additional line sections above, perform the same calculation.

### **8.3.3 Result**

The test fails if any of the following applies:

- a. The breaking strength measured during the line breaking strength tests of any sample of line material used in the construction of the test specimen, including brake lines, is less than 20 daN
- b.  $W_{max}$  of any line section is less than the test specimen model size's top weight

### **8.4 Test report**

The test report must include the elements specified in 10.1.

## 9 Flight test definition for certification<sup>2</sup>

### 9.1 Terms and definitions

In the context of this section, the following terms and definitions apply in addition to the general definitions in section 4.

**Harness:** assembly composed of straps and fabric for supporting the pilot in a seated or semi-recumbent position. The harness is attached to the wing via two connectors.

**Controls:** primary steering and speed controls which are designated as such by the manufacturer.

**Accelerator:** pitch control mechanism operated by the feet which automatically returns to the initial position when the action of the pilot stops.

**Action of the pilot:** any transfer of weight, action on the controls, the accelerator or on the trimmer.

**Normal flight:** flight condition in which the paraglider is fully inflated and is following a trajectory close to straight flight (at a speed close to trim speed) without any action on the part of the pilot. A small number of cells may still be collapsed.

**Spiral dive:** flight condition in which a paraglider is fully inflated follows a circling, steep, nose down trajectory. The pitch angle of 70° or more. The angle of the span relative to a horizontal line is between 0° and 40°.

**Spontaneous recovery:** without any action on the part of the pilot, the paraglider returns to normal flight.

**Front collapse:** front collapse is considered to have occurred when the top surface is visible from the underside of the paraglider. Deformation of the leading edge is not considered to be a front collapse.

**Cascade:** transition from one involuntary abnormal flight condition to another involuntary abnormal flight condition.

**Minimum speed:** slowest airspeed maintainable without entering a deep stall or full stall.

**Trim speed:** airspeed of the paraglider in straight flight without activating the controls or the accelerator.

**Maximum speed:** airspeed of the paraglider in straight flight with the controls in the zero position and the accelerator fully activated.

**Low speed:** airspeed of the paraglider in straight flight with the controls at 50 % of travel between the zero and the symmetric stall position (i.e. 50 % of the symmetric control travel)

**Folding lines:** A set of lines, going from one riser to attachment points placed in front of the same wing side's or the opposite wing side's A line attachment points.

**Weight in flight:** total weight (mass) of the pilot and his entire paragliding equipment (including the glider) ready to fly. For the purposes of this document masses are indicated in kg, rounded to the nearest integer value. The term "weight" may be used instead of mass.

### 9.2 Equipment

#### 9.2.1 Pilot equipment

The pilot performing the manoeuvres must be equipped with:

- Helmet in accordance with EN 966;

---

<sup>2</sup> This section is based on the EN standard definition EN 926-2.



- Radio communication system for announcing manoeuvres and comments in flight;
- Airspeed indicator;
- Variometer with adjustable acoustic sink alarms;
- Lifejacket (if the flight tests are carried out over water);
- Ballast system for adjusting the load in accordance with the manufacturer's requirements;
- Additional video cameras in the case a of manufacturer pilot performing manoeuvres;
- Emergency parachute which complies with EN 12491.

The total weight of the ballast must not exceed 15 kg or 20 % of the pilot's weight, whichever is larger.

### 9.2.2 Ground equipment

The ground personnel must be equipped with:

- Video camera to review the movements and actions of the pilot and the behaviour of the test specimen;
- Radio link with the test pilot to record his comments directly on the video tape.

## 9.3 Test specimen

The test specimen must be presented ready to fly and conforming in all points to the production model, including production-grade lines (without loops or knots), production-grade riser sets and a user's manual in a language acceptable to the testing laboratory.

### 9.3.1 Marking

#### 9.3.1.1 Canopy

The test specimen's canopy, on its intrados side, must be clearly marked in the following way on the wing half specified by the testing laboratory (see Figure 8):

1. A line must be marked from a point at 50 % of the trailing edge at a 45° angle to the leading edge.
2. Either side of this line, at distances of  $\pm 2.5\%$  of the wingspan (with a minimum of 50 cm and maximum of 75 cm measured between the inside of the parallel marks) parallel marks must be attached, indicating the tolerance area.
3. A line must be marked from a point of 50 % of the leading edge at a 45° angle to the trailing edge.

Marks must be contrasting and easily recognizable from the video documentation. All positions are percentages of the flat (i.e. non-inflated) span, and are determined with the test specimen laid flat.

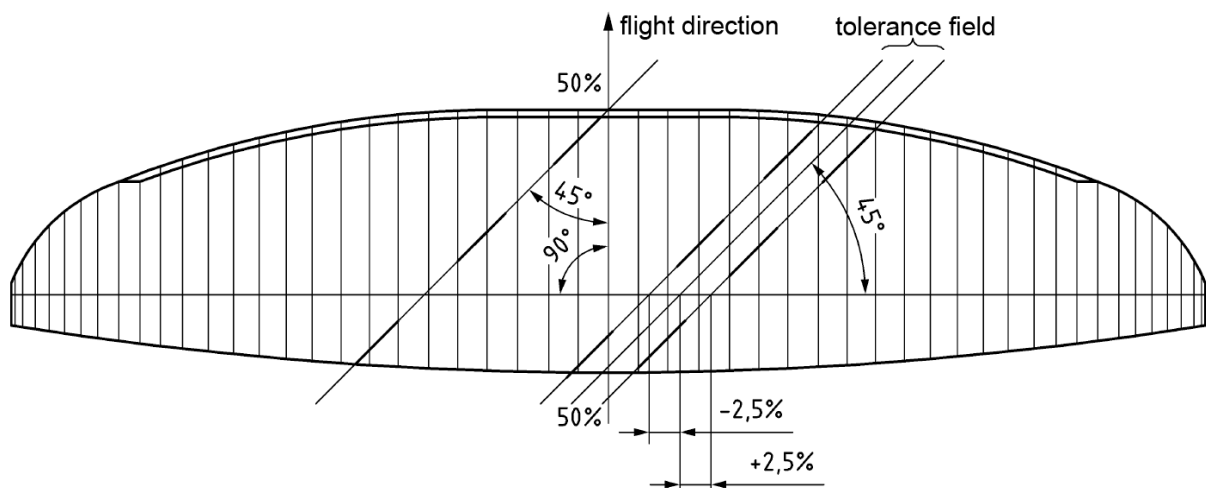

Figure 8: Canopy markingsControl lines

Zero and symmetric stall positions must be marked on the control lines:

1. The zero position mark is placed at the position of the control lines at which the first action on any point of the trailing edge can be observed.
2. To mark zero and symmetric stall positions, it is recommended that manufacturers attach an additional reference line to each side of the test specimen, running from the B riser to the seat of the harness, and incorporating elastic to maintain tension. Each reference line should be fitted with 2 adjustable toggles.
3. When moving the controls to a position to be marked, the pilot moves both the controls and the appropriate toggles down. When releasing the controls again, he lets go of the toggles (refer to the procedure in 9.5.2).

### **9.3.1.2 Streamer**

To help visualize the glide trajectory, a streamer 1 m long and 5 cm wide must be attached to a suitable line or riser.

### **9.3.2 Folding lines**

If due to the geometry of a paraglider's suspension line system any type of deliberate folding as defined in 9.5 cannot be achieved in accordance with the procedure description, the manufacturer is required to attach additional lines, so-called folding lines, to the test specimen, in order to enable the pilot to perform these manoeuvres as specified. If folding lines are used, this must be noted in the test report, and full details included in the user's manual, including attachment positions and line lengths.

Two types of folding lines can be used: symmetric and asymmetric.

#### **9.3.2.1 Symmetric folding lines**

Symmetric folding lines are used for achieving collapses as specified in 9.5 on paragliders where the standard technique of inducing collapses through the regular A risers results in pre-acceleration or pre-rotation to the point where the resulting collapses are no longer in accordance with the test specification. Symmetric folding lines can be used for symmetric and asymmetric collapse tests only: 9.5.5, 9.5.6, 9.5.10, 9.5.11, 9.5.12, 9.5.13 and 9.5.14. They must fulfil the following requirements:

1. For each side: One riser, a number of bottom lines attached to the riser, a number of mid-level lines attached to the bottom lines, a number of top lines attached to the mid-level lines and to the canopy.
2. The number of bottom folding lines attached to the folding line riser is not more than the number of main lines attached to the A riser.
3. From the bottom loop of the main riser, the folding line riser must have a total length of 1m with tolerance +/-1m.
4. From the bottom loop of the main riser, the linked length of folding lines riser plus bottom folding lines must match the corresponding linked length of the A bottom lines and riser, with a tolerance of + 1 m / -1 m at 5 daN tension.
5. There must be no more than 15 top folding lines per side.
6. All collapse lines, when not used to pull a collapse, must be slack in flight at all speed.

### **9.3.2.2 Asymmetric folding lines (also known as “cross line”)**

Asymmetric folding lines can be used for the large asymmetric collapse tests only: 9.5.12 and 9.5.13. They must fulfil the following requirements:

1. The setup consists of a riser, one bottom line attached to the riser, and up to three top lines attached to the bottom line and the canopy on the opposite side from the riser.
2. The minimum length of the bottom asymmetric folding line is the combined length of bottom and mid-level symmetric folding lines that lead to the same folding line attachment points.

### **9.3.2.3 Folding line attachment points**

Attachment points for folding lines must fulfil the following requirements:

1. All folding lines must be attached on the bottom surface of the canopy profile.
2. The minimum distance between leading edge and folding line attachment point must be 1% of the corresponding chord.
3. Folding lines must not be attached further backward than the corresponding top A lines.

## **9.4 Procedure**

### **9.4.1 General**

1. The test specimen’s behaviour in the programme of test manoeuvres defined in 9.5 is demonstrated by a manufacturer pilot in front of a test pilot of the testing laboratory carrying out the flight tests.
2. If this demonstration is satisfactory to the test pilot, the actual test is carried out.
3. The test consists of execution of all the test manoeuvres defined in 9.5 at the maximum weight in flight declared by the manufacturer. The tests are executed by the testing laboratory’s test pilot. Where indicated in the test description, the manoeuvre can be executed by a manufacturer pilot (see also 9.4.3).
4. If a test manoeuvre has not been performed in precise accordance with its procedure in 9.5, the manoeuvre must be repeated. This may be due to an error of the test pilot or due to meteorological influences.
5. The test specimen fails the flight test if either of the following applies:
  - a. As a consequence of any of the tests manoeuvres described in 9.5, any failure of any part or component of the test specimen occurs
  - b. Any of the test manoeuvres described in 9.5 fails

Otherwise the test specimen has passed the in-flight tests.

**Remark:** It is highly recommended that all test manoeuvres be carried out over water, and that appropriate safety measures are taken to pick up the pilot quickly in case of an emergency landing in the water.

### **9.4.2 Meteorological conditions**

The following meteorological conditions must be met during the tests:

1. Wind less than 20 km/h within the test perimeter
2. No turbulence within the test perimeter disturbing the flight tests.

### **9.4.3 Tests executed by manufacturer pilot**

For tests executed by a manufacturer pilot, the following additional requirements apply:

1. The tests are performed under direct observation of a test pilot from the testing laboratory.

2. In addition to the usual video recording equipment used to document the tests, the manufacturer pilot is equipped with one or more on-board video cameras to record control movements and accelerator use.
3. The correct execution of the tests is verified by the testing laboratory's test pilot through direct observation as well as inspection of all recorded video evidence.

#### **9.4.4 In-flight weight**

1. The maximum in-flight weight declared by the manufacturer must not exceed the maximum weight in flight as determined by the test specimen's structural (section 5.2.2) and line breaking (section 5.2.3) strength tests.
2. The test weight in flight must be achieved using a single pilot.
3. All weights are subject to an acceptable tolerance of  $\pm 2$  kg.
4. All speeds are subject to an acceptable tolerance of  $\pm 2$  km/h.

#### **9.4.5 Video documentation**

1. All the tests must be filmed on video. If required explicitly by the procedures 9.5, the test pilot maintains a defined course relative to the camera axis when starting the test manoeuvre.
2. In 9.5 the following terms are used:
  - a. Camera axis: Profile: The pilot maintains a course at a right angle to the horizontal projection of the camera axis.
  - b. Camera axis: Face-on: The pilot is approaching the camera along the horizontal projection of the camera axis.
3. If manoeuvres are executed by a manufacturer pilot, the manufacturer test pilot is equipped with one or more on-board video cameras to record control movements and accelerator use.

#### **9.4.6 Radio documentation**

Any comments of the pilot in flight must be recorded on the video. Using the radio connection to the camera, the test pilot must:

1. Announce which manoeuvre is about to follow;
2. Add any comment helping to evaluate the glider's behaviour (optional);
3. Announce if he is sure any manoeuvre just performed was not valid for some reason.

#### **9.4.7 Harness**

1. The test pilot must use a harness with a distance of between 41 and 43 cm from the riser attachment points (measured from connector centrelines) perpendicular to the seat board top surface.
2. The horizontal distance of the harness' riser attachment points (measured from connector centrelines) must be set to 42 cm.
3. In the case of a pilot's weight of less than 50 kg the horizontal dimension is reduced to 38 cm.
4. In the case of a pilot's weight of more than 80 kg the horizontal dimension is increased to 46 cm.
5. Provided that doing so does not compromise the pilot's safety, the tests manoeuvres 9.5.5 to 9.5.14 must be flown with a competition harness with leg fairing. This harness must have the same distances from riser attachment points to set board top surface and between riser attachment points as the corresponding harness used for the remaining tests manoeuvres.

#### **9.4.8 Ballast**

1. Any ballast must be tightly attached to the pilot and positioned as close as possible to the centre of gravity of a pilot sitting in the harness not carrying any ballast.
2. The use of water ballast is recommended for safety reasons.

### **9.4.9 Pilot position**

1. Unless the test procedure states otherwise, the pilot should adopt a normal upright sitting position, with feet perpendicularly below his or her knees.
2. If a test is executed with a harness with leg fairing, the pilot should initially adopt a normal upright sitting position, with his legs stretched out straight, in the position making optimal use of the leg fairing. Once a manoeuvre is initiated, the pilot should assume a fully upright position, with feet perpendicularly below his or her knees.

### **9.4.10 Controls in hand**

1. Unless the test procedure states otherwise, the pilot always holds the controls in his or her hands.
2. The term 'releasing the controls' means taking all tension off the control lines.

### **9.4.11 Wraps**

The test pilot must never need to use wraps unless the test procedure requires this.

### **9.4.12 Timing when starting test measurements**

In tests 9.5.7, 9.5.8, 9.5.10, 9.5.11, 9.5.12 and 9.5.13, timing starts from the instant that the controls reach the zero position after the pilot releases them.

### **9.4.13 Timing when exiting stalled flight conditions**

The glider is considered to have exited tests 9.5.7 and 9.5.8 when it reaches its furthest forward pitching point. If there is no noticeable pitching, the glider is considered to have exited any of these tests when the streamer reaches 45° to the horizon.

### **9.4.14 Pitch angles**

Measurement is of the change of angle. A straight line taken from the leading edge at the centre of the canopy to the pilot's buttocks is compared to the horizon before and after the manoeuvre.

### **9.4.15 Keep course**

A paraglider is considered to have kept its course throughout a test if it stays within 15° either side of its original course.

### **9.4.16 Twist**

In tests 9.5.10, 9.5.11, 9.5.12 and 9.5.13, a twist has occurred when after 5 s or after a turn of 360° the pilot's position still is rotated more than 180° relative to the glider's flying direction.

### **9.4.17 Collapse on the opposite side**

In tests 9.5.10, 9.5.11, 9.5.12 and 9.5.13, a collapse on the opposite side has occurred when less than 50 % of the span of the test specimen's leading edge is affected. If more than 50 % of the span is affected, this is considered a cascade.

## **9.5 Test manoeuvres**

### **9.5.1 Speeds in straight flight test**

**Performed by:** Testing laboratory test pilot

**Procedure:**

1. Assess the trim speed in 10 s stabilized straight flight.
2. Assess the minimum speed in 10 s stabilized straight flight.
3. Assess the riser configuration during stabilized straight and fully accelerated flight.

**Camera axis:** Camera not required

**Results:** The test fails if either of the following applies:

- a. The measured trim speed is less than 30km/h
- b. The speed range using the controls is less than 10 km/h
- c. The elements on the riser set designed to limit the top speed are not fully loaded and tight when the test specimen is fully accelerated

### 9.5.2 Control movement test

**Performed by:** Testing laboratory test pilot

**Procedure:**

1. Check the zero position and the symmetric stall position reference marks.
2. Stabilize the test specimen in straight flight at trim speed.
3. Over a period of 5 s gradually lower both controls to the symmetric stall position marks, being careful not to induce pitch oscillations.
4. Hold this position until the test specimen rocks back entering a full stall.
5. Assess the control forces throughout the procedure.

**Camera axis:** Camera not required

**Results:** The test fails if either of the following applies:

- a. There is less than 5 cm of free control line travel before the zero position reference mark is reached.
- b. Symmetric control pressure is increasing, symmetric control travel is less than 35cm
- c. Symmetric control pressure is approximately constant and symmetric control travel is less than 40cm for a total weight in flight up to 80kg
- d. Symmetric control pressure is approximately constant and symmetric control travel is less than 45cm for a total weight in flight between 80kg and 100kg
- e. Symmetric control pressure is approximately constant and symmetric control travel is less than 50cm for a total weight in flight greater than 100kg
- f. Symmetric control pressure is decreasing

### 9.5.3 Pitch stability exiting accelerated flight test

**Performed by:** Testing laboratory test pilot

**Procedure:**

1. Stabilise the test specimen in straight flight at maximum speed.
2. Abruptly release the accelerator and assess the behaviour.

**Camera axis:** Profile

**Results:** The test fails if the resulting dive forward is more than 60°

### 9.5.4 Pitch stability operating controls during accelerated flight test

**Performed by:** Testing laboratory test pilot

**Procedure:**

1. Stabilise the test specimen in straight flight at maximum speed.
2. Activate both controls symmetrically to 25 % of the symmetric control range within 2 s.
3. Hold that position for 2 s.
4. Slowly release both controls.

**Camera axis:** Any axis

**Results:** The test fails if a collapse occurs during this manoeuvre.

### 9.5.5 Symmetric front collapse test at trim speed

**Performed by:** Testing laboratory test pilot or manufacturer pilot

**Procedure:**

1. Stabilise the glider in straight flight at trim speed.
2. Release the controls and attach them to the risers (however, for safety reasons, the controls may be kept in the hands if the front collapse is achievable without significantly affecting the trailing edge).
3. By abruptly pulling the appropriate lines or risers, induce a symmetric front collapse over the entire leading edge with as little as possible, but at least 30 % of the centre chord affected. As soon as the collapse is achieved, let go of the lines/risers.
4. If the test specimen has not recovered spontaneously after 3 s or after 180° of turn (which ever happens first), act on the controls to recover (without inducing a deliberate stall).

**Camera axis:** Profile

**Results:** The test fails if either of the following applies:

- a. Recovery through pilot action does not occur within the first 5 s of pilot action
- b. During recovery, the test specimen dives forward more than 60° while entering a turn of more than 90°
- c. During recovery, the test specimen dives forward more than 90°

### 9.5.6 Symmetric front collapse test at maximum speed

**Performed by:** Testing laboratory test pilot or manufacturer pilot

**Procedure:**

1. Stabilise the glider in straight flight at maximum speed.
2. Release the controls and attach them to the risers (however, for safety reasons, the controls may be kept in the hands if the front collapse is achievable without significantly affecting the trailing edge).
3. By abruptly pulling the appropriate lines or risers, induce a symmetric front collapse over the entire leading edge. As soon as the collapse is achieved, let go of the accelerator and the lines/risers.
4. If the test specimen has not recovered spontaneously after 3 s or after 180° of turn (which ever happens first), act on the controls to recover (without inducing a deliberate stall).

**Camera axis:** Profile

**Results:** The test fails if either of the following applies:

- a. Recovery through pilot action does not occur within the first 5 s of pilot action
- b. After exit, the test specimen dives forward more than 60° while entering a turn of more than 90°
- c. After exit, the test specimen dives forward more than 90°

### 9.5.7 Exiting deep stall (parachutal stall) test

**Performed by:** Testing laboratory test pilot or manufacturer pilot

**Procedure:**

1. Slow down the test specimen, using the controls, to obtain a trajectory as close as possible to the vertical without significantly changing the shape of the wing (deep stall). If a deep stall cannot be achieved due to a very long control travel, the pilot takes wraps to shorten the control lines.
2. Once a deep stall is achieved, maintain it for 3 s.

3. Release the controls smoothly and gradually (in about 2 s) to the zero position.
4. If the glider has not recovered spontaneously in 5 s, act on the controls to recover, in accordance with the user's manual.

**Camera axis:** Profile

**Results:** The test fails if either of the following applies:

- a. Recovery through pilot action does not occur within the first 5 s of pilot action
- b. The dive forward on exit is greater than 90°
- c. A cascade occurs

### 9.5.8 High angle of attack recovery test

**Performed by:** Testing laboratory test pilot or manufacturer pilot

**Procedure:**

1. Attain a trajectory as close as possible to the vertical (deep stall), without activating the controls or the accelerator, and with the minimum amount of deformation of the canopy (usually by using the minimum necessary pull-down of the B risers).
2. Maintain this high condition for 3 s.
3. Then release the risers very slowly, symmetrically and continuously.
4. If the glider has not recovered spontaneously in 3 s, act on the controls to recover, in accordance with the user's manual.

**Camera axis:** Profile

**Results:** The test fails if either of the following applies:

- a. Recovery through pilot action does not occur within the first 3 s of pilot action
- b. A cascade occurs

### 9.5.9 Recovery from a developed full stall test

**Performed by:** Testing laboratory test pilot or manufacturer pilot

**Procedure:**

1. Stabilise the glider in straight flight at minimum speed.
2. Fully apply the controls and hold that position until the test specimen is in a maintained full stall. If a full stall cannot be achieved due to a very long control travel, the pilot takes wraps to shorten the control lines.
3. Release the controls slowly and symmetrically, until the canopy has approximately regained its inflated span.
4. Quickly and symmetrically fully release the controls in a period of 1 s. If the canopy's pitch oscillations don't die out, fully released the controls when the canopy, rocking forward, arrives above the pilot.

**Remark:** If an asymmetric collapse occurs, it is assumed that the release has not been sufficiently symmetrical, and the test manoeuvre should be repeated.

**Camera axis:** Profile

**Results:** The test fails if either of the following applies:

- a. The dive forward on exit is greater than 90°
- b. A cascade occurs
- c. Many lines are visibly slack during recovery



### 9.5.10 Small asymmetric collapse test at trim speed

**Performed by:** Testing laboratory test pilot or manufacturer pilot

**Procedure:**

1. Stabilize the glider in straight flight at trim speed.
2. Release the control handle on the side to be collapsed and attach it to the riser.
3. Pull down the appropriate lines on one side as fast as possible to collapse the canopy asymmetrically at approximately 50 % of the span along the marked line.
4. As soon as the collapse is achieved, release the lines quickly.
5. Take no further action and remain passive until the glider either recovers, or changes course by more than 360°, or 3 s elapse.
6. If the glider has not recovered, act to recover the glider.

**Camera axis:** Face-on

**Results:** The test fails if either of the following applies:

- a. Change of course until re-inflation is more than 180°, with dive or roll angle greater than 90°
- b. Re-inflation through pilot action does not occur within the first 5 s of pilot action
- c. A twist occurs
- d. A cascade occurs

### 9.5.11 Small asymmetric collapse test at maximum speed

**Performed by:** Testing laboratory test pilot or manufacturer pilot

**Procedure:**

1. Stabilise the glider in straight flight at maximum speed.
2. Release the control handle on the side to be collapsed and attach it to the riser.
3. Pull down the appropriate lines on one side as fast as possible to collapse the canopy asymmetrically at approximately 50 % of the span along the marked line.
4. As soon as the collapse is achieved, release the lines and the accelerator quickly.
5. Take no further action and remain passive until the glider either recovers, or changes course by more than 360°, or 3 s elapse.
6. If the glider has not recovered, act to recover the glider.

**Camera axis:** Face-on

**Results:** The test fails if either of the following applies:

- a. Change of course until re-inflation is more than 180°, with dive or roll angle greater than 90°
- b. Re-inflation through pilot action does not occur within the first 5 s of pilot action
- c. A twist occurs
- d. A cascade occurs

### 9.5.12 Large asymmetric collapse test at trim speed

**Performed by:** Testing laboratory test pilot or manufacturer pilot

**Procedure:**

1. Stabilize the glider in straight flight at trim speed.
2. Release the control handle on the side to be collapsed and attach it to the riser.
3. Pull down the appropriate lines on one side as fast as possible to collapse the canopy asymmetrically inside the tolerance field in accordance with 9.3.1.1. In the status of the maximum shape of the collapse, the bend line has to be completely (right through to the trailing edge) inside the marked tolerance field.

4. As soon as the collapse is achieved, release the lines quickly.
5. Take no further action and remain passive until the glider either recovers, or changes course by more than 360°, or 3 s elapses.
6. If the glider has not recovered, act to recover the glider.

**Camera axis:** Face-on

**Results:** The test fails if either of the following applies:

- a. Change of course until re-inflation is more than 180°, with dive or roll angle greater than 90°
- b. Re-inflation through pilot action does not occur within the first 5 s of pilot action
- c. A twist occurs
- d. A cascade occurs

### 9.5.13 Large asymmetric collapse test at maximum speed

**Performed by:** Testing laboratory test pilot or manufacturer pilot

**Procedure:**

1. Stabilise the glider in straight flight at maximum speed.
2. Release the control handle on the side to be collapsed and attach it to the riser.
3. Pull down the appropriate lines on one side as fast as possible to collapse the canopy asymmetrically inside the tolerance field in accordance with 9.3.1.1. In the status of the maximum shape of the collapse, the bend line has to be completely (right through to the trailing edge) inside the marked tolerance field.
4. As soon as the collapse is achieved, release the lines and the accelerator quickly.
5. Take no further action and remain passive until the glider either recovers, or changes course by more than 360°, or 3 s elapses.
6. If the glider has not recovered, act to recover the glider.

**Camera axis:** Face-on

**Results:** The test fails if either of the following applies:

- a. Change of course until re-inflation is more than 180°, with dive or roll angle greater than 90°
- b. Re-inflation through pilot action does not occur within the first 5 s of pilot action
- c. A twist occurs
- d. A cascade occurs

### 9.5.14 Directional control with a maintained asymmetric collapse test

**Performed by:** Testing laboratory test pilot or manufacturer pilot

**Procedure A:**

1. Stabilize the glider in straight flight at trim speed.
2. Release the control handle on the side to be collapsed and attach it to the riser.
3. Pull down the appropriate lines on one side as fast as possible to collapse the canopy asymmetrically at approximately 50 % of the leading edge along the marked line and hold the collapse.
4. Attempt to keep course for a period of 3 s, using the control on the inflated side if necessary.
5. From straight flight, further use this control to turn 180° to the inflated side in a period of 10 s without involuntarily entering an abnormal flight condition.
6. Assess the position of the control relative to the symmetric stall position mark.

**Remark:** The pilot must not counteract inertia effects on his or her body at any stage.

**Camera axis:** Face-on

**Results:** The test fails if either of the following applies:

- a. Unable to keep course
- b. 180° turn away from the collapsed side not possible in 10 s

### 9.5.15 Trim speed spin tendency test

**Performed by:** Testing laboratory test pilot

**Procedure:**

1. Stabilise the glider in straight flight at trim speed.
2. Over a period of 2 s activate one control to 25 % of the symmetric control range.
3. Wait 20 s or until the glider has turned 360°, then over a period of 2 s further activate the same control to 50 % of the remaining range, and wait 20 s or until the glider has turned another 360°, or the glider has obviously entered a spin.

**Camera axis:** Camera not required

**Results:** The test fails if a spin occurs.

### 9.5.16 Behaviour exiting a fully developed spiral dive

**Performed by:** Testing laboratory test pilot

**Procedure:**

1. Stabilize the glider in straight flight at trim speed.
2. Without weight-shift, apply a smooth progressive input with one brake until the glider enters a spiral dive. For a valid test, the glider should enter the spiral dive after a minimum of 5 s and a maximum of 1.5 turns without a spin or collapse occurring.
3. Hold the brake position reached while actively maintaining a central and neutral position relative to the risers (as if the harness was cross-braced).
4. Hold this position for 720°, then release the initiating brake smoothly and progressively in one turn.
5. While releasing the brake, no longer actively maintain a central and neutral position and allow the body to follow the inertial effects.
6. If the turn clearly tightens significantly, act to recover the glider. Otherwise let the glider recover from the spiral dive on its own.

**Camera axis:** Any axis

**Results:** The test fails if the turn tightens after releasing the controls, as observed by increasing g force and turn rate.

### 9.5.17 Alternative means of directional control

**Performed by:** Testing laboratory test pilot

**Procedure:**

1. Stabilise the glider in straight flight at trim speed.
2. Apply the alternative control method recommended in the user's manual without affecting the primary controls and perform a 180° turn.
3. Wait for 20 s or until the turn is completed.

**Camera axis:** Any axis

**Results:** The test fails if any of the following applies:

- a. No turn achievable in 20 s
- b. Stall or spin occurs

### 9.5.18 Quick descent option in straight flight

**Performed by:** Testing laboratory test pilot

**Procedure:**

1. Check whether at least one flight procedure for quick descent in straight flight is described in the user's manual.
2. Verify that the described quick descent option can be flown safely.

**Remark:** This requirement may be satisfied by the manufacturer producing suitable and acceptable evidence (e.g. video).

**Camera axis:** Camera not required

**Results:** The test fails if any of the following applies:

- a. No flight procedure for quick descent in straight flight given in the user's manual
- b. Procedure for quick descent in straight flight does not work as described
- c. A cascade occurs during execution of the quick descent flight procedure

### 9.5.19 Testing any other flight procedure and/or configuration described in the user's manual

**Performed by:** Testing laboratory test pilot

**Procedure:** Verify that every so-far untested flight procedure and/or configuration described in the user's manual can be flown safely.

**Remark:** This requirement may be satisfied by the manufacturer producing suitable and acceptable evidence (e.g. video).

**Camera axis:** Camera not required

**Results:** The test fails if any of the following applies:

- a. A flight procedure does not work as described
- b. A cascade occurs during execution of a described flight procedure

## 9.6 *Test report*

The test report must include the elements specified in 10.1.

## **10 Documentation requirements definition for certification<sup>3</sup>**

### **10.1 Test report**

The test report must include:

1. A reference to this CIVL Competition Class Definition, i.e. CIVL CCC 2015, Revision 3
2. The name and address of the test specimen's manufacturer
3. The name and address of the person or company presenting the test specimen for testing (if different from manufacturer)
4. Name and address of the testing laboratory
5. Names of the test pilots
6. Model and reference of the test specimen
7. Results of the measurements programme according to section 7
8. Results of the flight test programme according to section 8
9. Results of the stability test programme according to section 0, including values of loads in Newton and load times in seconds
10. Details of any damage after the test
11. Unique identifying test reference number

### **10.2 Additional material**

The following items must accompany the test report and be filed by the testing laboratory:

1. All video recordings of the tests (archived for a minimum of 10 years)
2. Manufacturing record, as defined in 10.2.1 (archived for a minimum of 10 years)
3. The test specimen that has undergone flight testing (archived for a minimum of 5 years)
4. [An Excel file including the needed information for control as defined in Appendix B. This file is sent to CIVL and to the manufacturers.](#)

#### **10.2.1 Manufacturing record**

The manufacturing record supplied by the manufacturer must include the following information:

1. Name and address of the manufacturer
2. Designation of test specimen
  - a. Model name
  - b. Model size
  - c. Year and month of manufacture of the test specimen
  - d. Serial number
3. User's manual with date of issue and version number (as defined in 10.3)
4. Maximum total weight in flight (top weight)
5. Plans with dimensions and tolerances of:
  - a. Upper surface
  - b. Lower surface
  - c. Cell wells (ribs)
  - d. Wing tips and stabilizers
  - e. Rigging
  - f. Method of assembly
6. Technical characteristics
  - a. Maximum wing span

---

<sup>3</sup> This section is based on the EN standard definitions EN 926-1 and EN 926-2.

- b. Trailing edge length
  - c. Surface area calculated according to the following equation:  
(maximum wing span) x (mean chord), where chord = maximum length of cell walls (ribs)
  - d. Weight of paraglider (canopy, lines and risers, in kg)
7. List of components and materials. All the materials used must be listed with:
- a. Name of the material
  - b. Manufacturer's and/or supplier's name and references
  - c. The material's specific use in the paraglider
  - d. Characteristics and tests carried out on this material by the supplier or manufacturer

**Note:**

1. The drawings and plans are provided in an annex to the manufacturing record. They permit the suspension lines, including any additional lines used for testing only, to be clearly seen and also give a plan view of all the components of the paraglider.
2. Drawings can be provided in electronic form, as long as their format is readable with standard office software.
3. In addition to any electronic form, suspension line and plan view drawings must be provided on paper.

### **10.3 User's manual**

The user's manual should be supplied in English, additional languages are optional. It must always be distributed along with each specimen sold. Its contents must cover the following:

1. General information
  - a. Paraglider model name
  - b. Manufacturer's name and address
  - c. Recommended minimum total weight in flight (in kg)
  - d. Permitted maximum total weight in flight (top weight, in kg)
  - e. Maximum symmetric control travel at top weight (in mm)
  - f. Maximum symmetric rear riser travel at maximum weight in flight (in mm)
  - g. Introduction to the intended use of the paraglider
  - h. Description of the paraglider's flight characteristics, in comparison with a glider that is certified as EN D
  - i. Version and date of issue of the user's manual
2. Manufacturer's recommendations on the levels of pilot skills required for safe operation.
3. Dimensions, illustrations and technical characteristics. **All information requested by Annex B must be clearly published in the Manual. These information are given by the test laboratories.**
  - a. Overall illustration identifying all components essential for operation
  - b. Canopy dimensions: chord length at wing centre, chord length at 25% of span, span, and trailing edge length when measured according to 7.1
  - c. Line attachment point positions
  - d. Projected area
  - e. Number of cells
  - f. Number of risers
  - g. Dimensioned drawings of the riser set, including lengths of all risers (distance between main carabiner loop and each maillon or line attachment point) both in trim and fully accelerated configuration
  - h. Maximum shortening of front-most risers relative to rear-most riser through accelerator

- i. Description of any adjustable, removable or variable device, besides controls and accelerator, with information on adjustment limits (if applicable). If no such device is present, this fact must be clearly specified
  - j. Dimensioned drawings of all suspension lines including control lines and any additional lines used for flight testing. Dimensions must include both individual section lengths (including the line material used for each section), and the overall lengths measured from the attachment points on the canopy to the inside edge of the maillon connecting them to the risers. Line lengths must be specified when measured according to 7.3.
  - k. Technical data on all suspension line materials: Manufacturer, manufacturer's code, diameter, core material, sleeve material, specified breaking strength, breaking strength after 5000 bending cycles
  - l. Harness dimensions used during flight testing
4. Manufacturer's recommendations on all necessary piloting techniques. In particular, these recommendations must describe and specify:
- a. Harness dimension used during testing
  - b. Pre-flight inspection procedure
  - c. Normal piloting techniques, including the procedure for laying out the wing before inflation/take-off
  - d. Use of accelerator and any other devices
  - e. Recovery from involuntary abnormal flight conditions (deep stall, asymmetric collapse etc.)
  - f. Rapid descent procedures
  - g. Procedure for steering in case of failure of the primary controls
  - h. Any other special flying procedure and/or configuration the manufacturer suggests to apply
  - i. Any recommendations and special considerations regarding SIV. In particular:
    - i. If folding lines were used for the flight tests, including a set with each paraglider is recommended. Alternatively, the manual must give information on how to obtain a set of folding lines
    - ii. Instructions on how to correctly mount and unmounts folding lines
5. Repair and maintenance instructions; in particular, these instructions must describe and specify:
- a. General information on maintaining and repairing the paraglider
  - b. Recommended frequency of inspections in months from purchase or accumulated hours flying time (whichever comes first)
  - c. Instructions for line measurements, re-trimming and replacements
  - d. Detailed instructions on any repair and maintenance procedures that can be performed without special knowledge or special machinery
  - e. List of spare parts and information how to obtain them

**Note:** The user's manual can be provided in electronic form, provided the format is readable with standard office software.

## 11 Measurement definitions for verification in competitions

These measurement and testing procedures must be applied during competitions to verify that a particular paraglider corresponds with its Competition Class model size sufficiently to not give its pilot an unfair advantage over other pilots. Additionally, these measurements and testing procedures provide pilots with a simple way to verify their wing's conformity with certification themselves. [The procedure for checking wings is set out in Annex B](#)

### 11.1 Canopy dimension verification

A paraglider passes verification if span, trailing edge and [three](#) chord measurements yield results that correspond with those documented in the paraglider's manual, within a tolerance of [+2%/- 2%](#) for span measurement and [+1%/- 1%](#) for chord and trailing edge measurement. [The chords to be measured are at the 1<sup>st</sup> rib outwards from the centre of the glider that has line attachments on it, the furthest outwards rib of line group A2, and the furthest outwards rib carrying lines \(typically the stabilo\).](#)

### 11.2 Line attachment point verification

A paraglider passes verification if

1. visual comparison of all line attachment points on the paraglider's canopy with the photographic documentation of the line attachment points on the paraglider's CIVL Competition Class model [and](#) size shows no difference in design, construction nor materials used
2. all [three measured chords have chord length and positions \(if any\) of the: inlet top, inlet bottom, Aa, Ab, Ba, Bb and C \(etc\) line attachments match those](#) documented for the paraglider's CIVL Competition Class model [and](#) size [with tolerance +10mm/-10mm](#)

### 11.3 Line length verification

As the starting point for all line length verifications, the actual overall line lengths are measured and recorded according to section 7.2. To speed up the measurement process, the complete length from main carabiner loop to attachment points may be measured, and the riser lengths deducted afterwards, as is standard practice for line measurements today.

#### 11.3.1 Relative line length verification 1: Angle of attack test

The purpose of this verification is to detect deliberate changes to the canopy's angle of attack with the intention of increasing the paraglider's performance. Additionally, this verification also allows pilots to verify whether their wing's line set complies with certification. Verification is done by executing the following test procedure:

1. [The length from the carabiner end of the riser to the sail is measured at each line attachment point.](#)
2. [For each line group \(groups based on lower main lines: A1, A2, A3; B1, B2, B3 etc\) the average line length is calculated.](#)
3. [For each line group the difference between the average A line length and the B line length is calculated. \(A1 – B1, etc\). The wing passes if the difference between average A line length and average B line length matches the value specified in the manual with tolerance +2cm/-2cm.](#)
4. [The glider fails if it is trimmed fast >-2cm. If the glider is trimmed slow >+10mm the pilot should be warned that the glider is out of trim and potentially unsafe.](#)



### 11.3.2 Relative line length verification 2: Camber test

This verification only applies to gliders with 3 or more lines chordwise. (see §4.17). The purpose of this verification is to detect deliberate changes to the canopy's camber (the arching of the profile in chord-wise direction) with the intention of increasing the paraglider's performance. The tests performed in 11.3.1 are repeated for each of the B and C line groups (groups based on the lower main lines: B1, B2, B3; C1, C2, C3 etc) to confirm that as well as the A-B differences, the difference between B and C groups matches the values specified in the manual +2cm/-2cm .

### 11.3.3 Absolute line length verification: Arc test

The purpose of this verification is to detect deliberate changes to the canopy's span-wise arc with the intention of increasing the paraglider's performance. Verification is done by executing the following test procedure:

For each line attached to the tested paraglider's canopy, calculate the difference between the nominal overall length given in the paraglider's user's manual, and the actual measured overall length. The glider fails if both lines of three or more symmetric line pairs differ from the manual nominal line length, with tolerance +5cm/-5cm.

## 11.4 Riser length verification

A paraglider passes verification if riser set measurements according to section 7.4 yield results that correspond with those documented in the paraglider's manual, and by the testing house, with a tolerance of 5 mm.

For each riser, the riser length is measured in the unaccelerated state, and under full acceleration. The glider passes if the difference in length between the accelerated and trim state matches the values given in the manual with tolerance of 5mm.

## 11.5 Line diameters, profiles and internal structure verification

A paraglider passes verification if:

1. a comparison with the model size's stored schematics as well as the model size's stored reference glider shows identical internal and external construction elements
2. all dimensional measurements of profile shape dimensions and internal structure element lengths yield results that differ by a maximum of the greater of +/- 1% or 5 mm from the corresponding lengths given in the model size's stored schematics as well as those measured on the model size's stored reference glider
3. all its line diameters are identical to the ones listed in the model size's stored schematics, as well as the ones present on the stored reference glider
4. To verify line diameters manufacturers must produce a reference card holding labelled samples of each of the line types used in the line set of each size of a paraglider model. Verification is confirmed by directly comparing the reference card lines with those on the wing being tested.

## Appendix A Maximum weight calculation example

This appendix is intended to explain the calculation used to establish the maximum weight in the line breaking strength test (section 8.3) by giving an example.

For this we look at hypothetical paraglider, the Progress Lambda. The Lambda was designed with a very revolutionary line setup as shown in Figure A-1. This line setup serves to explain how the calculation is done in the different scenarios that may occur on real-life paragliders. Note that the Progress Lambda is a pure two-line glider, which is reflected in the calculation below.

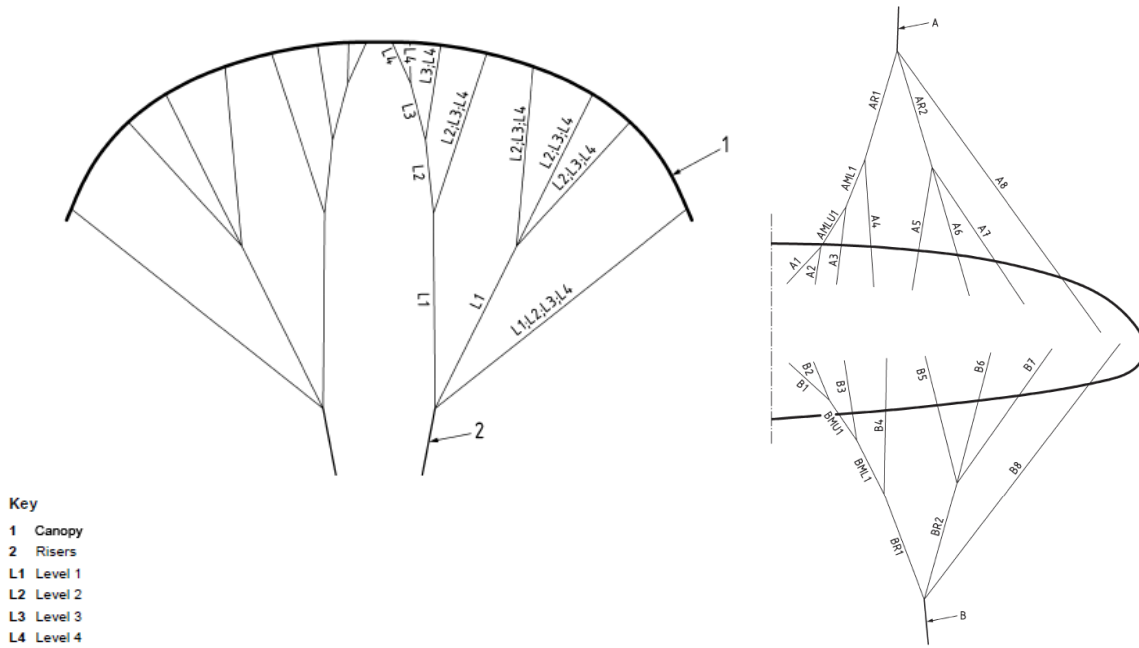

**Figure A-1: Line setup of Progress Lambda**

The Lambda L is supposed to be certified up to 130 kg. Table A-1 shows the calculation to determine the maximum weight for this glider. Note that the hypothetical setup presented here for testing fails the line breaking strength tests, since the maximum weight calculated for level 3 is below the target of 130 kg.

The calculation details are:

$$g = 9.81 \text{ m/s}^2$$

$$F_{break\ Level_i} = \sum_{\text{line types in level } i} F_{break} * Occurrence_{level_i}$$

$$W_{max\ Level_i} = \frac{F_{break\ Level_i}}{14g}$$

Paragliders permitted in FAI Category 1 Cross-Country events

Line	Line type	Breaking force new (daN)	Breaking force after bending test (daN)	Number of lines	Breaking force after bending for whole level (daN)			
					Level 1	Level 2	Level 3	Level 4
A1	9000U-090	88	48.6	2				97.2
A2	9000U-090	88	48.6	2				97.2
A3	9000U-090	88	48.6	2			97.2	97.2
A4	9000U-090	88	48.6	2		97.2	97.2	97.2
A5	9000U-125	125	69.1	2		138.1	138.1	138.1
A6	9000U-125	125	69.1	2		138.1	138.1	138.1
A7	9000U-125	125	69.1	2		138.1	138.1	138.1
A8	9000U-110	110	60.8	2	121.5	121.5	121.5	121.5
AMU1	TCT-130	115	63.5	2			127.1	
AML1	254UT-300	298	164.6	2		329.3		
AR1	7348-450	412	227.6	2	455.2			
AR2	7348-400	355	196.1	2	392.3			
B1	9000U-090	88	48.6	2				97.2
B2	9000U-090	88	48.6	2				97.2
B3	9000U-090	88	48.6	2			97.2	97.2
B4	9000U-090	88	48.6	2		97.2	97.2	97.2
B5	9000U-125	125	69.1	2		138.1	138.1	138.1
B6	9000U-125	125	69.1	2		138.1	138.1	138.1
B7	9000U-125	125	69.1	2		138.1	138.1	138.1
B8	800U-130	120	66.3	2	132.6	132.6	132.6	132.6
BMU1	TCT-130	115	63.5	2			127.1	
BML1	254UT-300	298	164.6	2		329.3		
BR1	7348-450	412	227.6	2	455.2			
BR2	7348-400	355	196.1	2	392.3			
					F <sub>break</sub> Level 1 (daN)	F <sub>break</sub> Level 2 (daN)	F <sub>break</sub> Level 3 (daN)	F <sub>break</sub> Level 4 (daN)
					1949.2	1935.9	1726.0	1860.8
		MaxLoad (kg)	130		W <sub>max</sub> Level 1 (kg)	W <sub>max</sub> Level 2 (kg)	W <sub>max</sub> Level 3 (kg)	W <sub>max</sub> Level 4 (kg)
					141.9	141.0	125.7	135.5

Table A-1: Line breaking strength calculation for Progress Lambda L (test failed)

## **Appendix B Excel Template file for measuring gliders**

An Excel file is available from CIVL and has been sent to manufacturers and Test Houses. It is a template including the needed information for measure gliders.

# CCC Document - Annex B

## General principle for CCC glider controls

- Processes, documents and any modification are published on the CIVL website.
- Reliable measurement instruments and processes must be in place before the controls are fully implemented in Category 1 competition.
- Measures are taken by the Test Laboratories after the flight tests. Test Laboratories verify that the Manufacturer Manual measurements comply with the tolerances.
- Once they are verified, the Test Laboratories send the Manufacturers Manual measurements to CIVL in a template .xls file. These measurements are the basis of CIVL controls. Tolerances applied are specified in the CCC document.
- The glider User's Manual must include the same measurements as the Manufacturer Manual.
- Pilots are reminded that modifications that take a glider outside certification are not permitted (Section 7 - 11.1.2), whether the modified part of the glider is controlled or not.
- Controls others than described here can be done if thought necessary.
- Controls are done after a complaint or at the discretion of the Meet Director. Pilots must make available the glider or other equipment for checking, immediately upon any such request. It is suggested that:
  - Task winners' gliders are controlled.
  - If such gliders have already been controlled, they can be controlled again (primarily lines only). In this case, gliders arriving 2nd are also controlled.
  - Podium gliders are controlled (primary lines only if they have already been controlled).
  - Meet Directors anticipate and control potential podium gliders before the final day, so on this day only primary lines have to be controlled.

## Example of gliders controls during the competition

### Step 1: on site

Full span  
Trailing edge  
Chord 1  
Inlet top 1  
Inlet bottom 1  
Tab Aa 1  
Tab Ab 1  
Tab B 1  
Tab C 1  
Chord 8  
Inlet top 8  
Inlet bottom 8  
Tab Aa 8  
Tab Ab 8  
Tab B 8  
Tab C 8  
Stabilo A  
Stabilo B  
Stabilo C  
Risers neutral  
Risers accelerated  
Lines length  
Lines diameters (not everyone, a few at random choice)  
...

### Step 2: on site, if needed

Check with other supposed valid glider (other generation?)  
Tension band, diagonals, reinforcements, material...  
Glider aspect when flat on ground  
...

### Step 3

Glider is sent to Test Laboratory for complete check.

# Example of data from Test Laboratories

**Brand** Butterfly  
**Model** Magic Flower  
**Size** Small  
**CCC certification n°** CCC 20140816 0001  
**Certification date** 2014 08 16

## Canopy dimensions

	Rib n° from center	Mm	Tension
Full Span		12802	3 Kg
1/2 Tailing Edge		6490	3 Kg
Chord of first rib with lines	3	2098	1 Kg
Top of inlet of first rib with lines	3	1938	1 Kg
Bottom of inlet of first rib with lines	3	1915	1 Kg
Chord of last rib with lines Group 2	26	1328	1 Kg
Top of inlet of last rib with lines Group 2	26	1224	1 Kg
Bottom of inlet of last rib with lines Group 2	26	1209	1 Kg
Chord stabilo with lines	41	716	1 Kg

## From trailing edge to tab

Chord first rib with lines could be different for A & B	Rib n° from center	Mm	Tension
Tab Aa	4	1825	1 Kg
Tab Ab	4	1722	1 Kg
Tab B	3	839	1 Kg
Tab C	4	489	1 Kg

Chord first rib with lines Group B could be different for A & B	Rib n° from center	Mm	Tension
Tab Aa	26	1386	1 Kg
Tab Ab	26	1284	1 Kg
Tab B	26	741	1 Kg
Tab C	26	358	1 Kg

Chord last stabilo with lines from center	Rin n° fromcenter	Mm	Tension
--	----------------------	----	---------

Tab A	41	625	1 Kg
Tab B	41	287	1 Kg

### Absolute line length from bottom riser to canopy

Rib with lines n°	Aa	Ab	Ba	Bb	C	BRAKES
Aa1.Ab 1.Bb1.C 1	7289	7256	7242	7337	8500	
Aa2.Ab 2.Bb2.C 1	7166	7132	7108	7215	8223	
3	7128	7094	7081	7215	8068	
4	7175	7144	7175	7300	8049	
5	7062	7035	7034	7164	7900	
6	6952	6926	6918	7048	7801	
7	6907	6883	6887	7012	7754	
8	6941	6920	6963	7061	7866	
9	6741		6727		7731	
10	6656		6656		7683	
11	6586		6621		7730	
12	6569		6651		7858	
13	6506		6570			
14	6490		6567			

### Riser length

Figure 2 & 3 CCC 7.4.1	A1, A2	A3, Stab	B1, B2, B3	Tension
Neutral	520	520	520	5 Kg
Accelerated	400	456	514	5 Kg

### Table of lines: suppliers name and reference

Ref.	Mat.	Ref.	Mat.	Ref.	Mat.	Ref.	Mat.	Ref.	Mat.
A		B		C		D		BRAKE	
a1	8000	b1	8000	c1	8000	d1	8000	br1	DC
a2	8000	b2	8000	c2	8000	d2	8000	br2	DC
a3	8000	b3	8000	c3	8000	d3	8000	br3	DC
a4	8000	b4	8000	c4	8000	d4	8000	br4	DC
a5	8000	b5	8000	c5	8000	d5	8000	br5	DC
a6	8000	b6	8000	c6	8000	d6	8000	br6	DC
a7	8000	b7	8000	c7	8000	d7	8000	br7	DC
a8	8000	b8	8000	c8	8000	d8	8000	br8	DC
a9	8000			c9	8000			br9	DC



a10	8000			c10	8000		br10	DC
a11	8000			c11	8000			
a12	8000			c12	8000			
a13	8000			c13	8000			
A1	12240	C1	8000					
A2	12240	C2	8000					
A3	12240	C3	8000					
A4	12240	C4	8000					
A5	12240	C5	8000					
A6	12240	C6	8000					
A7	12240	C7	8000					
A8	12240	C8	8000					
A9	8000							
A10	8000							
Stab	8000							
2a1	12470	1c1	16330					
2a2	12470	1c2	12470					
2a3	12470	1c3	12470					
2a4	12470	1c4	16330					
2a5	16330	1c5	8000					
		1c6	8000					
3a1	12950	2c1	16560					
3a2	12950	2c2	16560					
3a3	16330	2c3	12240					

**Suspension lines**

**Fabric code**

**Supplier**

Upper cascades	DC-040	Liros GMHB (Germany)
Upper cascades	8000-045	Edelrid (Germany)
Upper cascades	8000-060	Edelrid (Germany)
Middle cascades	DC-040	Liros GMHB(Germany)
Middle cascades	8000-045	Edelrid (Germany)
Middle cascades	8000-060	Edelrid (Germany)
Middle cascades	8000-080	Edelrid (Germany)
Middle cascades	8000-080	Edelrid (Germany)
Middle cascades	16140-070	Cousin (France)
Middle cascades	12240-115	Cousin (France)
Middle cascades	16330-145	Cousin (France)
Main	12240-115	Cousin (France)
Main	16330-145	Cousin (France)
Main	16560-240	Cousin (France)
Main	12950-405	Cousin (France)
Main break	TNL-280	Teijim limited (Japan)

# Pictures & drawings requested from Test Laboratories

Span, chord and trailing edge

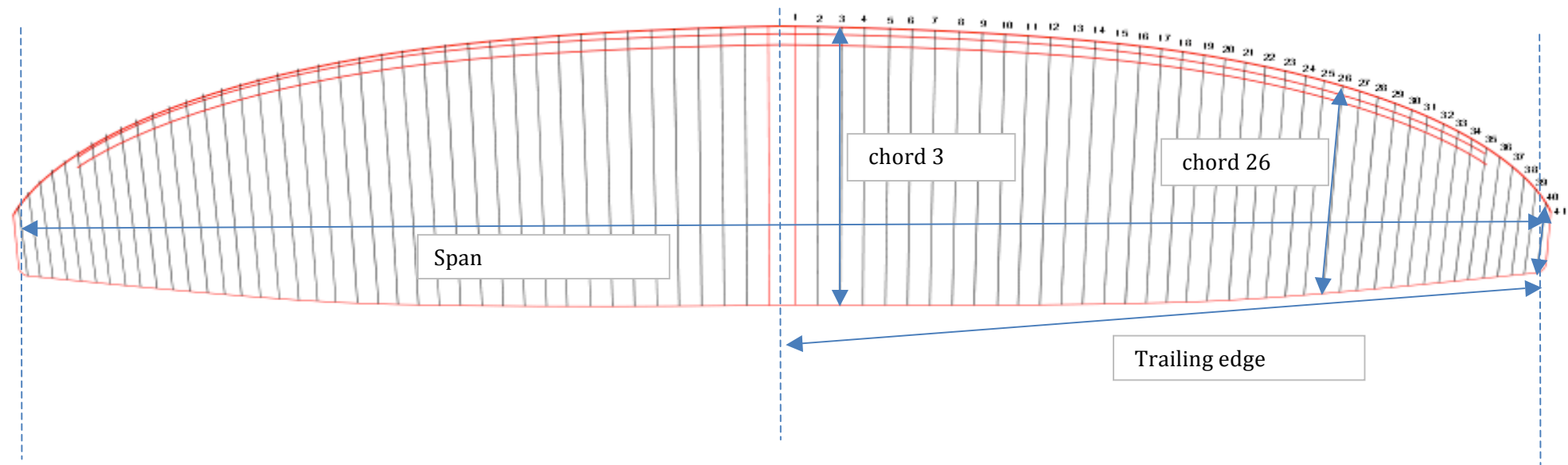

# Tabs positions and numbers

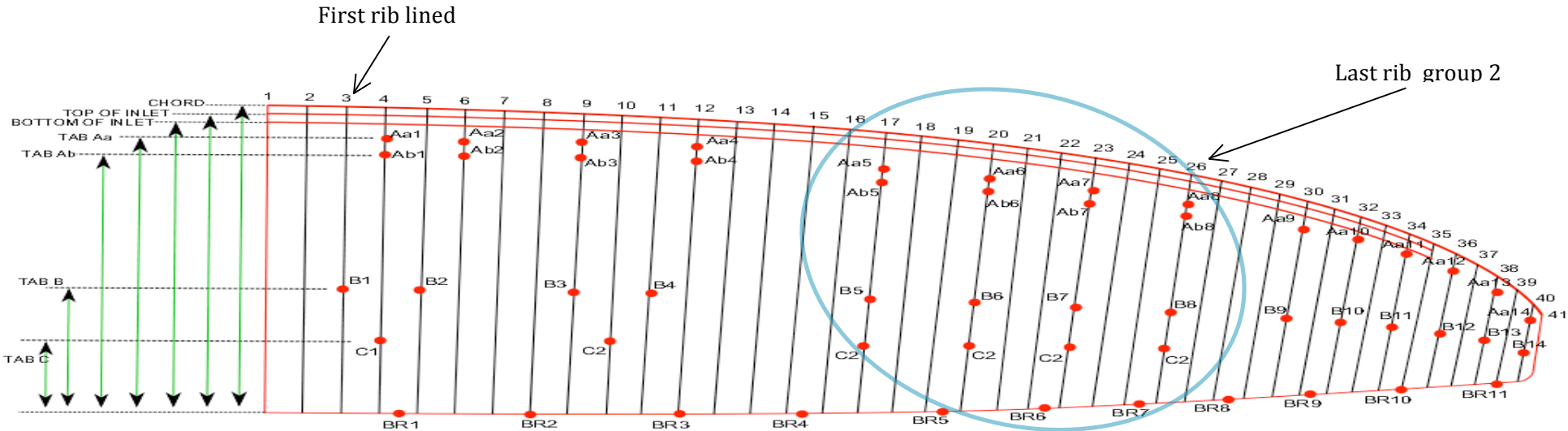

Tension bands

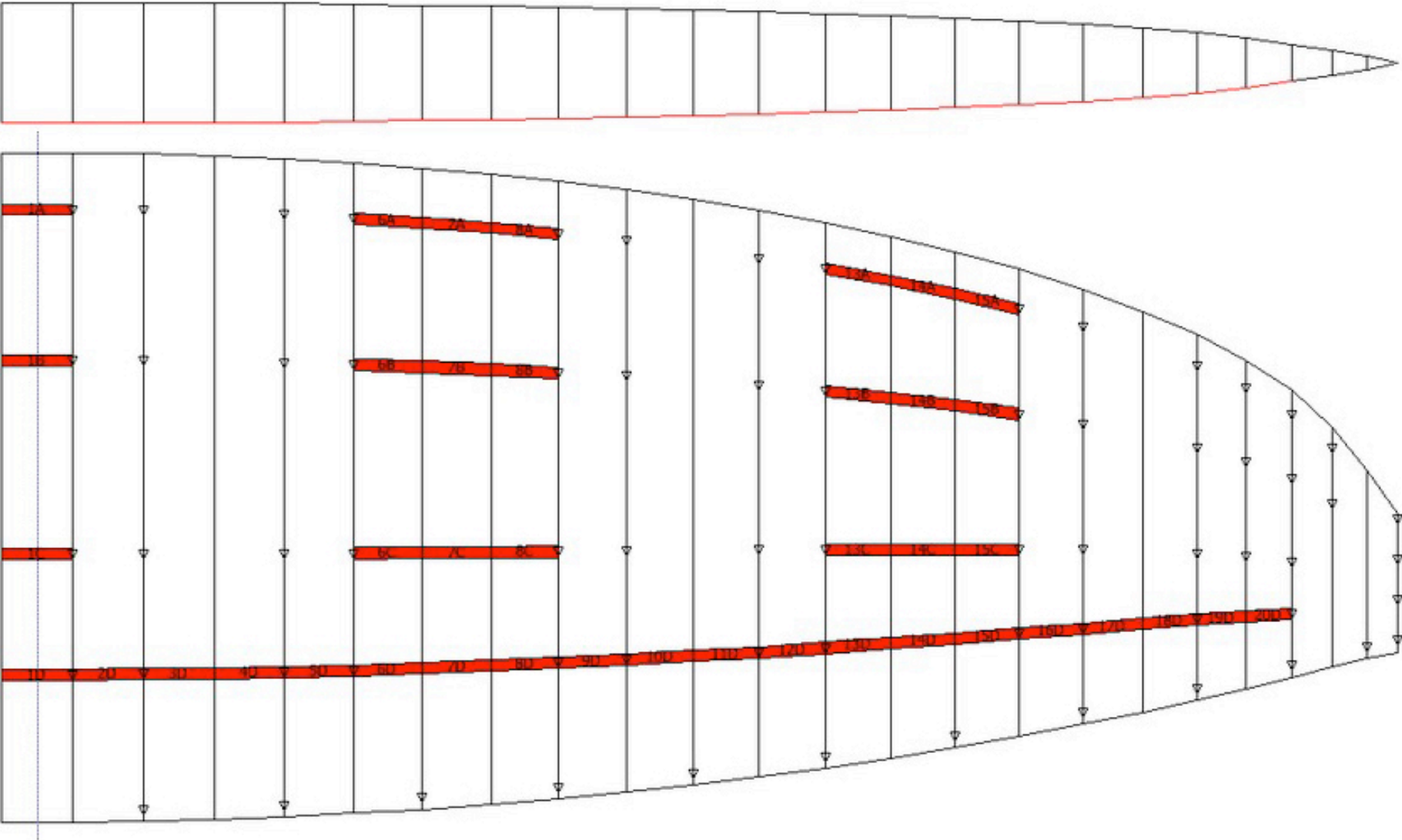

Mini ribs

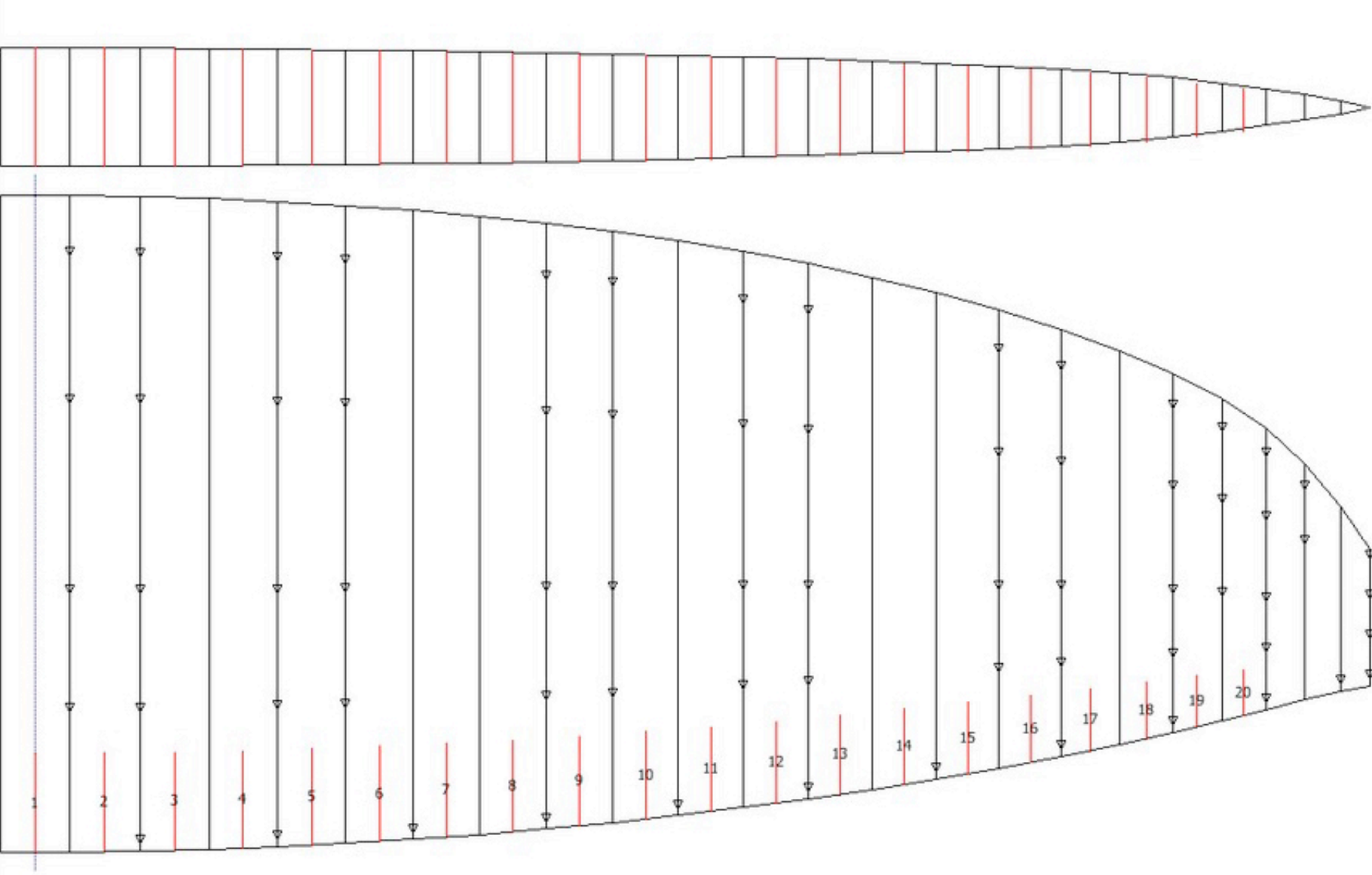

# Rigging diagram

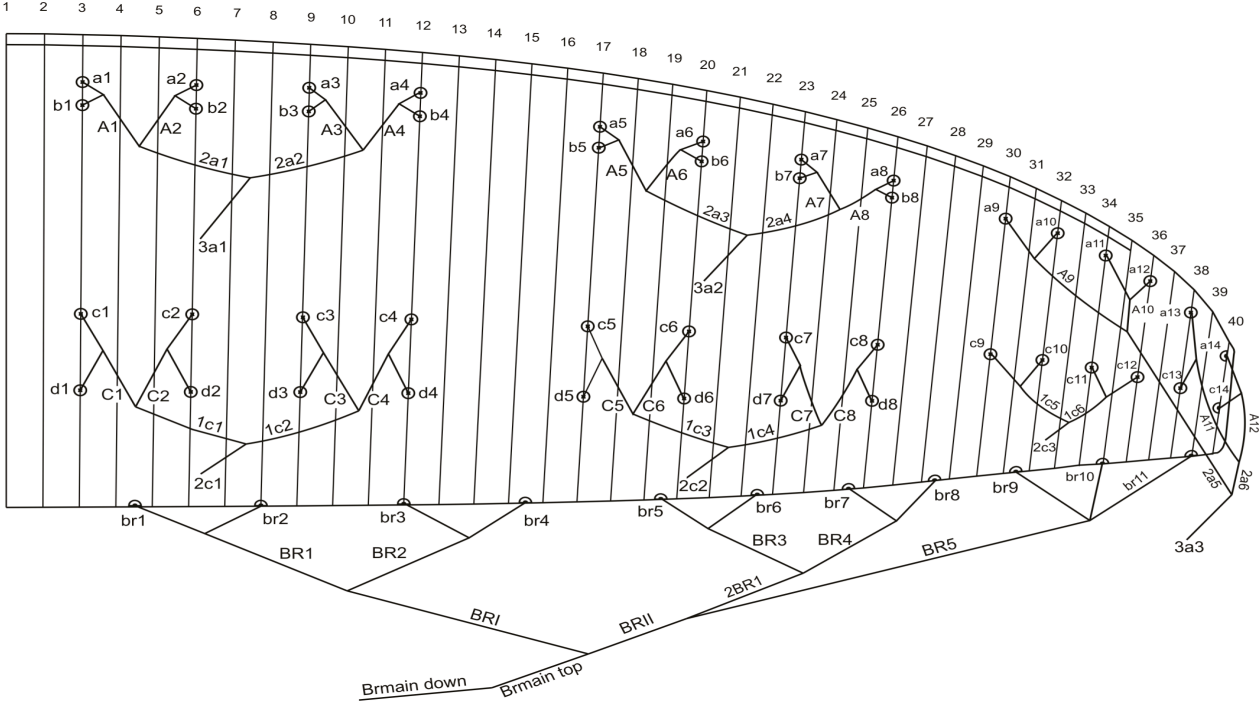

Diagonal

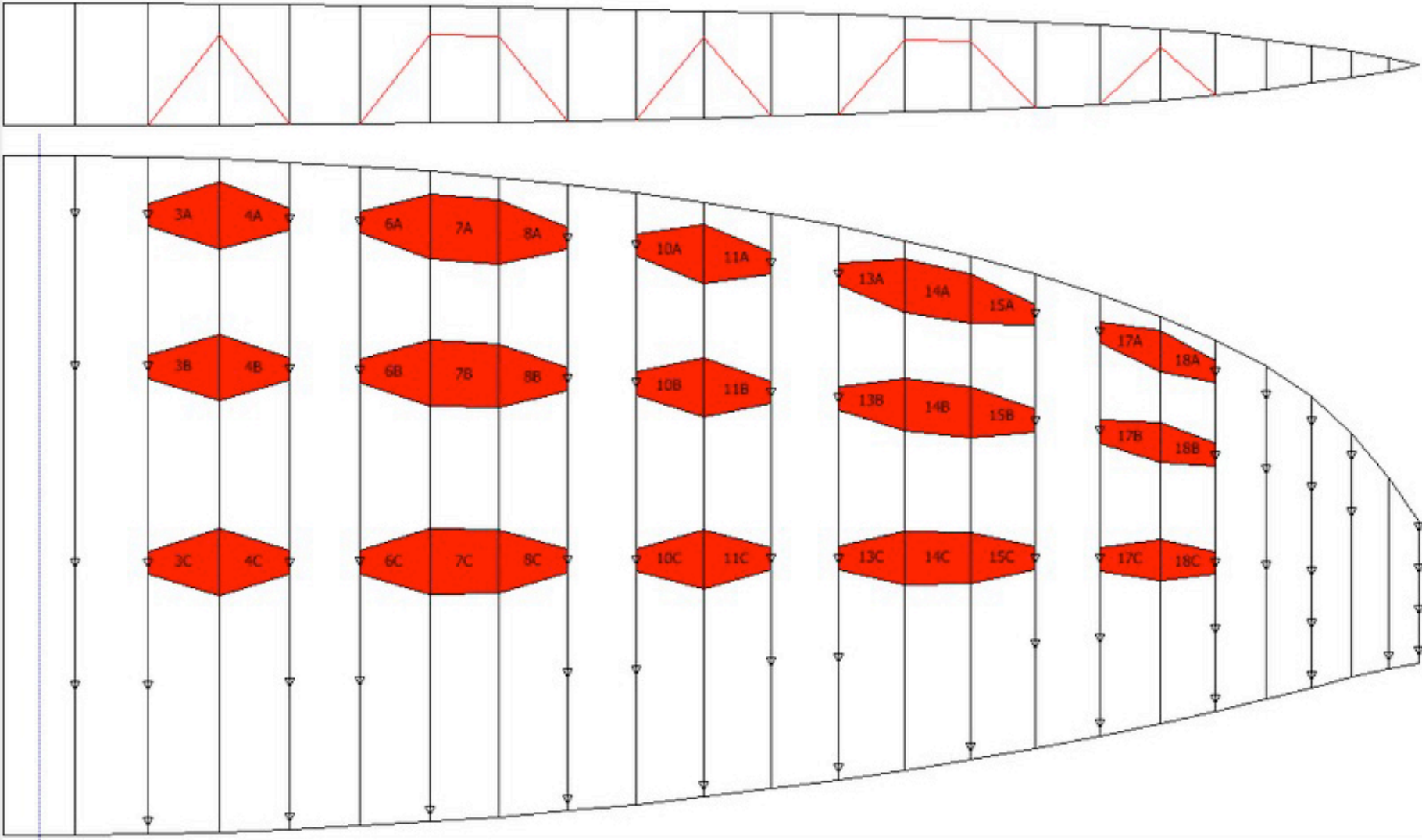

**Inlet shape**

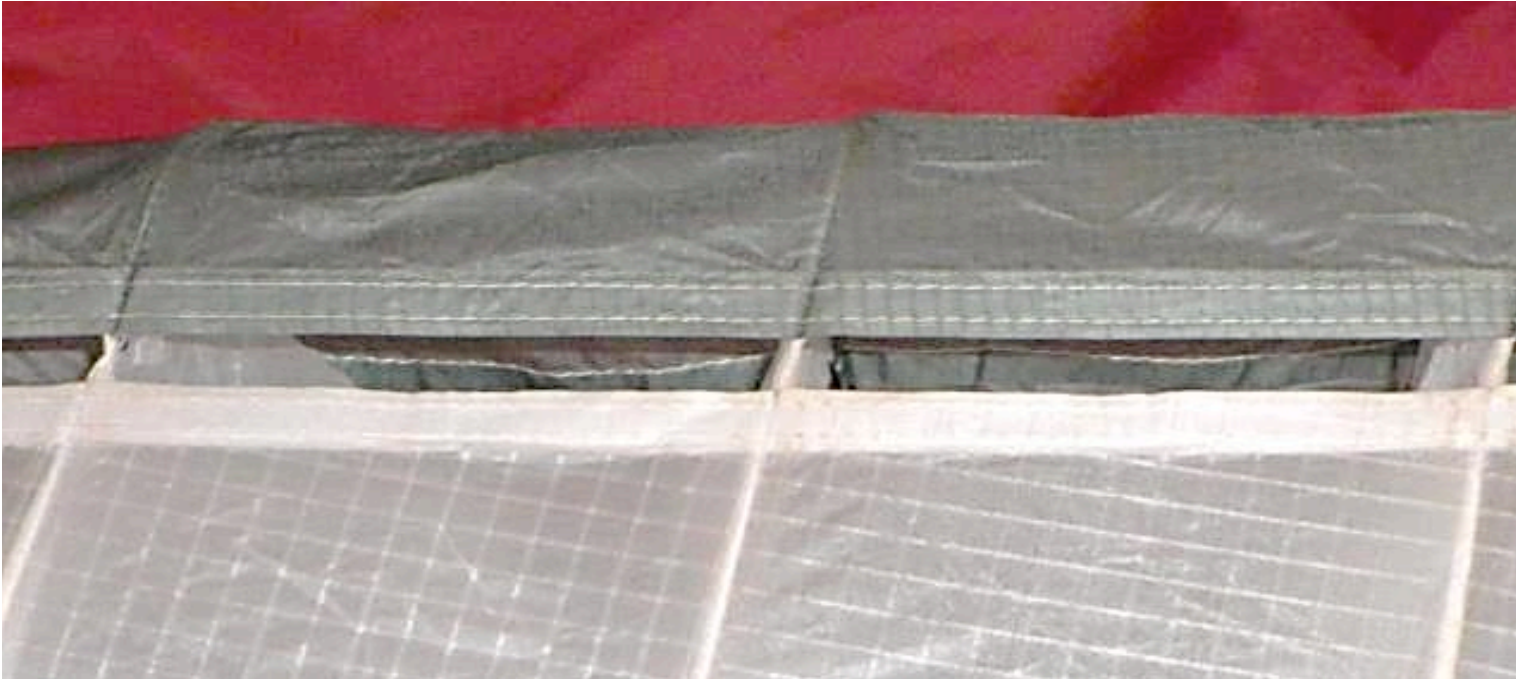



# General control process

