



TASK CATALOGUE
for the
10th World Paramotor Championship Test Competition
at
Pasak Jolasid Dam, Thailand
27 April to 6 May 2018
Organised by
The Royal Aeronautic Sports Association of Thailand
on behalf of the
FÉDÉRATION AÉRONAUTIQUE INTERNATIONALE

The Royal Aeronautic Sports Association of Thailand

171 Aeronautical and Space Science Museum Building, Phahonyothin Rd., Don Meung, Bangkok, 10210, Thailand

Tel: +66 (0) 2 523 9448, +66 (0) 2 531 8987 FAX: +66 (0) 2 531 3767

E-mail: rasat.faihailand@gmail.com

Official Web Site: <http://www.rasat-faihailand.com>

AUTHORITY

This Task Catalogue is to be used in conjunction with the Local Regulations. The General Section and Section 10 of the FAI Sporting Code takes precedence over the Local Regulation and Task Catalogue wording if there is ambiguity.

CLARIFICATION

Classes PF and PL are "Paramotors"

The scoring of navigation tasks in this catalogue is the 'traditional' format but these are translated into ABG format in the AOPC individual and team general scores as described in the local regulations.

CONTENTS

AUTHORITY	1
CLARIFICATION	1
CONTENTS	1
P1 PRECISION TAKE-OFF	2
P2 SHORT TAKE-OFF OVER A FENCE	3
P3 PRECISION LANDING	4
P4 BOWLING LANDING	5
P5 CLOVER LEAF SLALOM	6
P6 JAPANESE SLALOM	7
P7 CHINESE SLALOM	8
P8 ROUND THE TRIANGLE	9
P9 THE EIGHT	10
P10 PARABALL	11
P11 PRECISION WING CONTROL	12
P12 PRECISION WING CONTROL – GROUND HANDLING	13
E1 PURE ECONOMY	14
E2 ECONOMY & DISTANCE	15
E3 ECONOMY & NAVIGATION	16
E4 SPEED TRIANGLE & OUT AND RETURN	17
N1 PURE NAVIGATION	18
N2 NAVIGATION / ESTIMATED SPEED	19
N3 CURVE NAVIGATION	20
DECLARATION SHEET	21

P1 PRECISION TAKE-OFF

Task type: Precision ¹

Objective

To make a clean take off at the first attempt.

Description

Pilots proceed to their designated takeoff deck and prepare to be ready to take off.

Pilots must NOT take off until they are sure an observer is ready to judge their takeoff performance. (eg. a green flag is waved). Unobserved takeoffs will be penalised.

The pilot receives:

- 1st place for a clean take off at the first attempt.
- 2nd place for a clean take off at the second attempt.
- 3rd place for a clean take off at the third attempt.
- 4th place for a successful takeoff after four or more takeoff attempts.

Penalties

5th place

- Unobserved takeoff.
- Out of takeoff order.
- Unreasonable takeoff delay.
- Running out of the takeoff deck.

Scoring

Is described above. **This small task is worth 50% of the competition score. For example, if there are 22+ pilots competing, the first place will receive 15 points in the competition score.**

¹ This task is scored independently but is usually included before another flying task. To provide a decent level of competition it should only be deployed in nil or very light wind conditions.

P2 SHORT TAKE-OFF OVER A FENCE

Task type: Precision²

Objective

To take off in as short distance as possible. This task is intended to be included as a small element of another task.

Description

Takeoff permission is granted after the pilot has indicated he is ready to take off. The maximum distance on the ground, from where the pilot's feet or aircraft wheels have been since the start signal, to where the pilot's feet or aircraft wheels permanently leave the ground will be measured and scored. (permanently is defined as aircraft is airborne for more than 10 sec.)

Special rules

- There will be time and distance limits established at briefing according to the weather conditions. If not otherwise briefed, the time limit for this task is 1 min. No restrictions on number of attempts within the time limit. No penalties for the wing touching the ground on each attempt. If not otherwise briefed, the distance limit is 30 m. Exceeding either time or distance limits will be signaled with red flag and scored zero.

Penalties

Last place

- Breaking the fence or weaving.

Scoring

Pilot score = Maximum distance from start to fence in cm (shortest distance is best).³

This small task is worth 50% of the competition score. For example, if there are 22+ pilots competing, the first place will receive 15 points in the competition score.

Notes

Marking pilot's footsteps or wheels on the ground can be a tricky task for marshals. Using 2-3 m long rods (sail battens, fishing rods or similar) has proven to be effective to help in fixing visual observation results on the ground before they are measured.

Alternative methods can be developed and used for more precise measurements

² This task is scored independently but is usually included before another flying task.

³ The distance measured is the maximum distance the pilot is away from the fence whilst touching the ground, thus if the pilot moves away from the fence during launch then this distance shall be included.

P3 PRECISION LANDING

Task type: Precision ⁴

Objective

To land as near as possible to a target.

Description

The pilot enters the designated circuit pattern at minimum 500 ft AGL which is in principle circular with the landing target at its centre.

A **green flag** is waved; pilot immediately flies to the centre of the circle. A **good start** is when the pilot is overhead the target with engine off within 30 seconds of the green flag being first waved.

After at least one minute in the air since turning off his engine, the pilot attempts to make a first touch as near as possible to the centre of a 2.5m radius target. ⁵

The point from which the pilot's score will be derived is the first touch by the pilot's foot (PF) or wheel (PL).

The pilot must vacate the landing area to a safe distance as soon as possible after landing.

If, after a good start, a landing attempt is baulked for some recognisable reason outside the pilot's control or there is a technical problem, then a **white flag** will be waved; the pilot may land in a safe place and will be permitted to re-start the landing task as soon as possible without penalty.

Penalties

Last place

- Engine off for less than one minute before first touch.
- First touch outside the target.
- Falling over as a result of the landing.

Scoring

Pilot score = $(r - D_p)$

Where:

r = radius or total length of the target (in cm)

D_p = Distance of pilot's first touch from the centre of the target. (in cm)

This small task is worth 50% of the task score. For example, if there are 22+ pilots competing, the first place will receive 15 points in the competition score.

⁴ This task is scored independently but is usually included at the end of another flying task.

⁵ The target may be equipped with an electronic accuracy mat. Its size and resolution will be briefed.

P4 BOWLING LANDING

Task type: Precision ⁶

Objective

Land without engine, hitting as many pins as possible.

Description

5-10 pins are placed along a line into wind in the landing area at regular intervals between 1 and 2m.⁷

The pins are 30-50 cm high and should be reasonably soft and lightweight. They can simply stand on the ground or be lightly set into the ground, or can be attached to a spring system like that of the kicking sticks. A pin is said to be hit when it is clearly seen by a marshal or electronic sensor to be hit, or when the pin falls down.

The pilot enters the designated circuit pattern at min. 500 ft AGL which is in principle circular with the landing pins at its centre.

A **green flag** is waved; pilot immediately flies to the centre of the circle. A **good start** is when the pilot is overhead the target with engine off within 30 seconds of the green flag being first waved.

They will fly a minimum of 60 seconds and will try to hit as many pins as possible before touching the ground.

Penalties

Last Place

- Engine off for less than one minute before first touch.
- Striking no pins.
- Falling over as a result of the landing.

Scoring

Pilot Score = Number of pins hit (most pins hit is best)

This small task is worth 50% of the task score. For example, if there are 22+ pilots competing, the first place will receive 15 points in the competition score.



⁶ This task is scored independently but is usually included at the end of another flying task.

⁷ Normally 2m, but this may be reduced in windier conditions.

P5 CLOVER LEAF SLALOM⁸

Task type: Precision

Objective

To strike a number of targets laid out in a given order in the shortest possible time.

Description

4 inflatable pylons 12m in height are laid out at the corners of a 70.71m square for PF1 and PL1 and a 100m square for PF2 and PL2.

A fifth target is set at the centre of the square.

The pilot flies to the assigned circuit area and waits to start the task as briefed.

A **green flag** will be waved to indicate the pilot must start the task.

A **good start** is when the pilot kicks, or attempts to kick the first stick within his start slot.

The pilot enters the course from a direction of his choice and strikes the target T (strike 1). At this point the clock starts. The pilot flies around pylon 2 and returns to kick the stick T (strike 3), he then flies around pylon 4 and returns to kick the stick T (strike 5). This continues until all four pylons have been rounded. The clock stops when target T is kicked for the last time (strike 9).⁹

A valid strike on the target T is when the electronic 'kick stick' sensor detects it, or if automatic detection is not in use, where the pilot or any part of the Paramotor has been clearly observed to touch it.

To count as a strike, the pilot's body must be clearly seen to round pylons 2 & 8 in an ANTI CLOCKWISE direction and pylons 4 & 6 in a CLOCKWISE direction.

Pilots may have only one attempt at striking each target except for the first and last targets where three attempts at each are permitted.

A technical problem with the course will cause a **white flag** to be waved; the pilot must return to the circuit area and await the green flag for a re-start without penalty.

If the **red flag** is waved, the pilot must return immediately to the landing area.

Penalties

10 seconds added to pilot time:

- Delay of more than 30 sec between green flag and first attempt to strike target T.
- Each missed strike.

Last place:

- Entering the course out of order.
- Failure to strike the first or last target.
- Failure to achieve at least two other strikes.
- Touch the ground at any point between strikes 1 & 9

Scoring

Pilot task score = Pilot time + pilot time penalties. (shortest time is best).

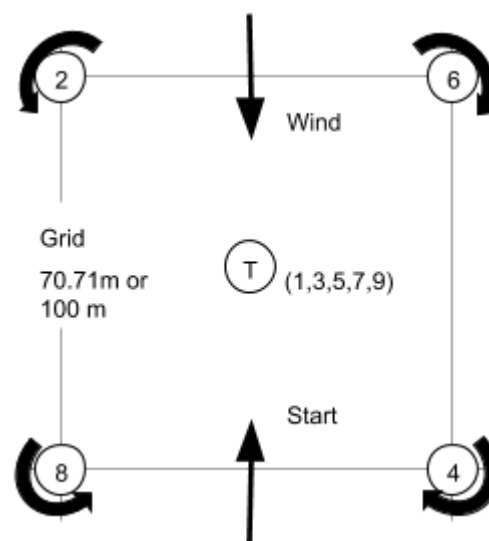

⁸ This task is eligible for FAI World records, If it is thought there might be a valid claim it is vital the claimant alerts the Jury so they can measure the course for validity before it is dismantled. For further guidance see the [Championship Record Claim Form](#)

⁹ A good time in this task is less than 50 sec.

P6 JAPANESE SLALOM¹⁰

Task type: Precision

Objective

To strike a number of targets laid out in a given order in the shortest possible time.

Description

4 targets (sticks) 1.8m in height are laid out on a 70.71m x 70.71m grid for PF1 and PL1 and 100m x 100m for PF2 and PL2.

The pilot flies to the assigned circuit area and waits to start the task as briefed.

A **green flag** will be waved to indicate the pilot must start the task.

A **good start** is when the pilot kicks, or attempts to kick the first target within his start slot.

The pilot enters the course into wind and strikes target 1. At this point the clock starts. The pilot then strikes targets 2 and 3. He then returns to fly clockwise around target 1 (strike 4), anticlockwise around target 2 (strike 5) and clockwise around target 3 (strike 6). He then returns to strike target 1 (strike 7), target 4 (strike 8) and target 3 (strike 9). The clock stops when target 3 (strike 9) is kicked¹¹.

Strikes 1,2,3,7,8 and 9 are valid when the electronic 'kick stick' sensor detects it, or if automatic detection is not in use, where the pilot or any part of the Paramotor has been clearly observed to touch it.

Strikes 1 & 3 are valid when the pilot's body is clearly seen to round the target in a CLOCKWISE direction.

Strike 5 is valid when the pilot's body is clearly seen to round the target in an ANTI CLOCKWISE direction.

Pilots may have only one attempt at striking each target except for the first and last targets where three attempts at each are permitted.

A technical problem with the course will cause a **white flag** to be waved; the pilot must return to the circuit area and await the green flag for a re-start without penalty.

If the **red flag** is waved, the pilot must return immediately to the landing area.

Penalties

10 seconds added to pilot time:

- Delay of more than 30 sec between green flag and first attempt to strike target 1.
- Each missed strike.

Last place:

- Entering the course out of order.
- Failure to strike the first or last target.
- Failure to achieve at least two other strikes.
- Touch the ground at any point between strikes 1 & 9

Scoring

Pilot task score = Pilot time + pilot time penalties. (shortest time is best).

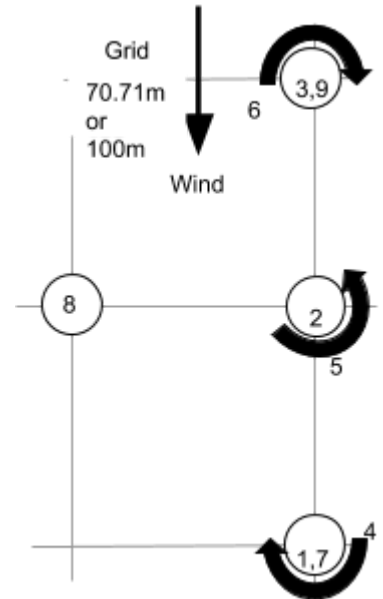

¹⁰ This task is eligible for FAI World Records. If it is thought there might be a valid claim it is vital the claimant alerts the Jury so they can measure the course for validity before it is dismantled. For further guidance see the [Championship Record Claim Form](#)

¹¹ A good time in this task is less than 1 min 10 sec.

P7 CHINESE SLALOM

Task type: Precision

Objective

To strike a number of targets laid out in a given order in the shortest possible time.

Description

Between 6 and 12 targets are laid out on a course not exceeding 3Km in length¹². Targets are sticks, intermediate targets may also be min. 8m inflatable pylons.

The pilot flies to the assigned circuit area and waits to start the task as briefed.

A **green flag** will be waved to indicate the pilot must start the task.

A **good start** is when the pilot kicks, or attempts to kick the first stick within his start slot.

The pilot enters the course and strikes target 1. At this point the clock starts. The pilot then flies the course to strike all the other targets in the given order, a strike on the last one stops the clock.¹³

Strikes are valid when the electronic 'kick stick' sensor detects it, or if automatic detection is not in use, where the pilot or any part of the Paramotor has been clearly observed to touch it, or if a target is an inflatable pylon, when the pilot crosses in the correct direction the line which defines when a pylon is passed.

Pilots may have only one attempt at striking each target except for the first and last targets where three attempts at each are permitted.

A technical problem with the course will cause a **white flag** to be waved; the pilot must return to the circuit area and await the green flag for a re-start without penalty.

If the **red flag** is waved, the pilot must return immediately to the landing area.

Penalties

10 seconds added to pilot time:

- Delay of more than 30 sec between green flag and first attempt to strike target 1.
- Each missed strike.

Last place:

- Entering the course out of order.
- Failure to strike the first or last target.
- Failure to score at least two other strikes.
- Touch the ground at any point between the first and last target.

Scoring

Pilot task score = Pilot time + pilot time penalties. (shortest time is best).

¹² This task is ideally suited for sites where there are physical features which obscure a direct view from one target to the next.

¹³ No 'good time' can be stated for this task as the course length is variable.

P8	ROUND THE TRIANGLE
-----------	---------------------------

Task type: Precision

Objective

To strike a number of targets laid out in a given order in the shortest possible time.

Description

The course consists of 4 targets (1.8m sticks) and a 12m inflatable pylon.

The distance from stick 1 to 2 is 70.71 m, the side of the equilateral triangle is 60m, and the distance between stick 2 to pylon 6 is 50 to 200m.

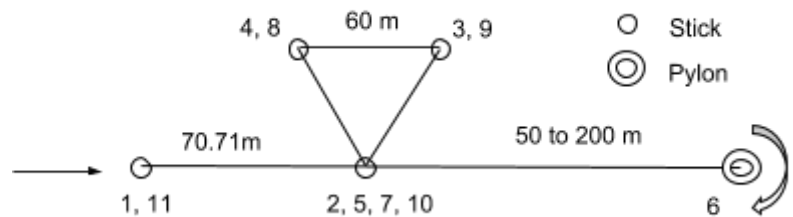

The pilot flies to the assigned circuit area and waits to start the task as briefed.

A **green flag** will be waved to indicate the pilot must start the task.

A **good start** is when the pilot kicks, or attempts to kick the first stick within his start slot.

The pilot enters the course as indicated by the arrow and strikes the first target (strike 1). At this point the clock starts. The pilot flies kicking the sticks in the triangle (strikes 2, 3, 4 and 5), then clockwise around pylon 6 (strike 6), returns to kick the sticks in the triangle (strikes 7, 8, 9 and 10) and then back to the initial stick (strike 11). The clock stops on strike 11.¹⁴

Strikes on sticks are valid when the electronic 'kick stick' sensor detects it, or if automatic detection is not in use, where the pilot or any part of the Paramotor has been clearly observed to touch it.

Strike 6 is valid when the pilot's body is clearly seen to round the pylon in a CLOCKWISE direction.

Pilots may have only one attempt at striking each target except for the first and last targets where three attempts at each are permitted.

A technical problem with the course will cause a **white flag** to be waved; the pilot must return to the circuit area and await the green flag for a re-start without penalty.

If the **red flag** is waved, the pilot must return immediately to the landing area.

Penalties

10 seconds added to pilot time:

- Delay of more than 30 sec between green flag and first attempt to strike target 1.
- Each missed strike.

Last place:

- Entering the course out of order.
- Failure to strike the first or last target.
- Failure to achieve at least two other strikes.
- Touch the ground at any point between the first and last target.

Scoring

Pilot task score = Pilot time + pilot time penalties. (shortest time is best).

¹⁴ With the pylon at 100m from stick 2, a good time in this task is less than 1 min 10 sec.

P9 THE EIGHT

Task type: Precision

Objective

To strike a number of targets laid out in a given order in the shortest possible time.

Description

The course consists of one central target (1.8m stick) and two 12m inflatable pylons 50m away on both sides.

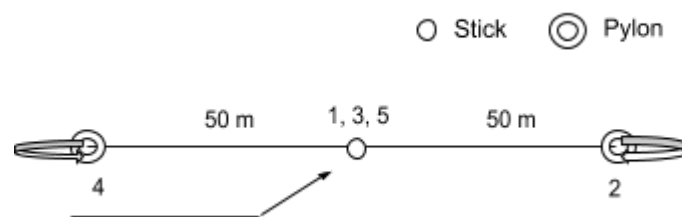

The pilot flies to the assigned circuit area and waits to start the task as briefed.

A **green flag** will be waved to indicate the pilot must start the task.

A **good start** is when the pilot kicks, or attempts to kick the first stick within his start slot.

The pilot enters the course as indicated by the arrow and kicks the stick (strike 1). At this point the clock starts. The pilot flies around the pylon ahead of him clockwise (strike 2), then kicks the stick (strike 3), then the other pylon counter clockwise (strike 4) and kicks the stick (strike 5). The course is repeated twice, the clock stops on strike 9.¹⁵

The course may be flown in a mirror image pattern consistent with the description above, thus the pilot has a choice of four different starting directions.

Strikes on sticks are valid when the electronic 'kick stick' sensor detects it, or if automatic detection is not in use, where the pilot or any part of the Paramotor has been clearly observed to touch it.

Strikes 2,4,6 & 8 are valid when the pilot's body is clearly seen to round the pylon in a direction consistent with the pattern.

Pilots may have only one attempt at striking each target except for the first and last targets where three attempts at each are permitted.

A technical problem with the course will cause a **white flag** to be waved; the pilot must return to the circuit area and await the green flag for a re-start without penalty.

If the **red flag** is waved, the pilot must return immediately to the landing area.

Penalties

10 seconds added to pilot time:

- Delay of more than 30 sec between green flag and first attempt to strike target 1.
- Each missed strike.

Last place:

- Entering the course out of order.
- Failure to strike the first or last target.
- Failure to achieve at least two other strikes.
- Touch the ground at any point between the first and last target.

Scoring

Pilot task score = Pilot time + pilot time penalties. (shortest time is best).

¹⁵ A good time in this task is less than 55 seconds.

P10 PARABALL

Task type: Precision; PF only.

Objective

Deliver balls to a target in the shortest possible time.

Description

The target is a 'basket' 2m in diameter and 1m deep.¹⁶

A circle of 5m radius is marked on the ground around the target.

3 balls¹⁷ are placed in a line 30-50m downwind from the target on marked start positions 3m apart from each other.

The pilot flies to the assigned circuit area and waits to start the task as briefed.

A **green flag** will be waved to indicate the pilot must start the task.

A **good start** is when the line the balls are on is crossed within 30 seconds of the green flag first being waved.

Timing starts when the line the balls are on is crossed (whether a ball is touched or not). The pilot approaches a ball, collects it with his feet and carries it to the target, or kicks the ball towards the target. This is repeated until all the balls are in the target or the time limit of 2 minutes is reached.

Timing ends when the last ball enters the target¹⁸ or when the maximum time limit is reached.

Balls must stay in the target. Balls that bounce out will be scored according to the distance from the target.

There are no limitations to the number, angle, speed or height of approaches to the balls, the number of times a ball may be touched, or the technique for hitting or carrying the balls. The pilot may touch and move on the ground, but the wing must not touch the ground during the task.

If a pilot is carrying a ball in the air when the time limit is reached, he is allowed extra time¹⁹ to complete delivery of the ball to the target. This extra time finishes when the ball next touches the ground or after 30 seconds, whichever comes first.

A **red flag** is waved when the task has ended. Results are then measured at this state.

Penalties

5 seconds added to pilot time:

- For each ball which finishes inside the 5m zone but not in the basket.

10 seconds added to pilot time:

- Delay of more than 30 sec between green flag and first attempt to touch a ball.
- For each ball which finishes outside the 5m zone.

Last place:

- Entering the course out of order.
- Failure to touch at least two balls.
- Wing touches the ground during the task.

Scoring

Pilot task score = Pilot time + pilot time penalties. (shortest time is best).

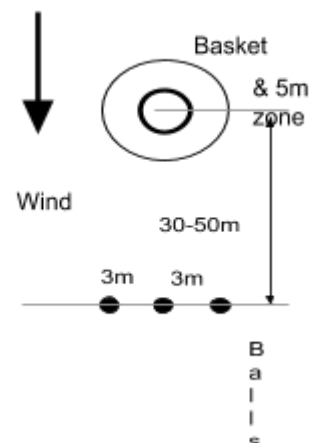

¹⁶ Construction should be light for safety reasons but strong enough to hold the force of a flying ball and to keep balls inside.

¹⁷ Footballs are OK, but larger balls of 55 Cm dia. are better, eg 'gym balls'. In all cases they should be rather softly inflated so the pilot can get a good purchase on the ball and it doesn't bounce too well when dropped.

¹⁸ With the basket at 30m, a good time in this task is less than 60 sec.

¹⁹ If 2 minutes is reached and all balls are on the ground, no extra time, red flag is waved.

- If 2 minutes is reached and a ball is being carried by pilot in the air, red flag operator waits until either ball touches ground, or extra time is finished. If the ball is still not on the ground, pilot scores as if the ball is outside the 5m zone.

Extra time is NOT included in the measured elapsed time, which is always max. 2 minutes. Thus, if a pilot manages to drop a 3rd ball into the basket during extra time he will score 2 minutes.

P11 PRECISION WING CONTROL**Objective**

Land and display precise control of the wing before taking off again.

Description

This task will normally be flown in wind conditions in which a reverse launch is possible. A straight course consisting of two sticks is laid out facing approximately into wind. The precise distance between the sticks is arbitrary but they should be a minimum of 100m apart. The pilot enters the course into wind. They must kick the first stick to start their time. They must then land in between the two sticks, bringing the wing down such that the trailing edge is clearly seen to touch the ground.

When a marshal has confirmed that wing has touched the ground they will show a green flag as a signal that the pilot may take off again.

The pilot will then launch and kick the second stick to stop the timer.

Special rules

A valid strike on a stick is:

EITHER one where the pilot or any part of the Paramotor has been clearly observed to touch it.

OR when electronic 'kick stick' sensors which have been shown to meet the standard tests are used, a valid strike is one which is recorded by the device.

- The clock starts the moment the pilot kicks the first stick and stops the moment he kicks the second stick.
- The pilot may have 3 attempts at kicking each stick.
- If a launch fails the pilot may make as many attempts as they need to relaunch the wing, within the specified time limit.
- The maximum time allowed for a pilot to complete the course is 3 minutes.

Penalties

10 seconds added to pilot time:

- Delay of more than 30 sec between green flag and first attempt to strike target 1.

Last place:

- Entering the course out of order.
- Failure to strike the first or last target.
- Pilot relaunched the wing before being shown a green flag by the marshal

Scoring

Pilot task score = Pilot time + pilot time penalties. (shortest time is best).

P12	PRECISION WING CONTROL – GROUND HANDLING
------------	---

Objective

Land and display precise control of the wing before taking off again.

Description

A straight course consisting of two sticks is laid out facing approximately into wind. The precise distance between the sticks is arbitrary but they should be a minimum of 200m apart.

At the centre point between the sticks a minimum of five pins are placed in line with the sticks. The pins are small plastic cones of the type used in sports training. The task director will specify the distance between each pin at the briefing

The pilot enters the course into wind. They must kick the first stick to start their time. They must then land before the first pin, keeping the wing flying in the air above them.

Whilst kiting the wing, they should walk or run through the course of pins, turning in alternate directions around each one to follow a slalom course. The body of the pilot must be clearly observed to pass outside of the line of pins when making each turn, and they must not touch any of the pins. After the pilot has passed the final pin, they will then launch as quickly as possible and kick the second stick to stop the timer.

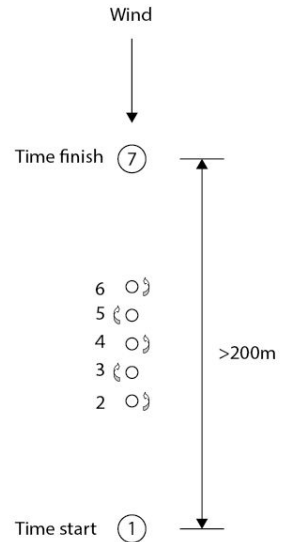
**Special rules**

- A valid strike on a stick is:

EITHER one where the pilot or any part of the Paramotor has been clearly observed to touch it.

OR when electronic 'kick stick' sensors which have been shown to meet the standard tests are used, a valid strike is one which is recorded by the device. - The clock starts the moment the pilot kicks the first stick and stops the moment he kicks the second stick.

- The pilot may have 3 attempts at kicking each stick.

- The pilot may turn either to the left or to the right when rounding the first of the pins, so long as they alternate the turn direction on each subsequent pin. - If the wing drops to the ground whilst the pilot is running through the slalom course they may relaunch it as many times as they need within the specified time limit.

- The maximum time allowed for a pilot to complete the course is 3 minutes

- Each pin that is touched by the body of the pilot in the course counts as a missed target.

- Each time the pilot fails to turn outside the line of pins it counts as a missed target.

Penalties

10 seconds added to pilot time:

- Delay of more than 30 sec between green flag and first attempt to strike target 1.
- Each missed strike.

Last place:

- Entering the course out of order.
- Failure to strike the first or last target.
- Failure to achieve at least two other strikes.

Scoring

Pilot task score = Pilot time + pilot time penalties. (shortest time is best).

E1 PURE ECONOMY ²⁰

Task type: Economy

Objective

Take-off with a measured quantity of fuel and stay airborne for as long as possible and return to the deck.
Free take-off within the time window.

Penalties

Last Place:

- Unobserved takeoff
- Departure from view of the marshals or egress from the permitted flight area
- Land outside the deck

Scoring

Pilot task score = Pilot time + pilot time penalties. (longest time is best).

²⁰ If max 1.5 kg of fuel is specified, this task is eligible for FAI World Records. For further guidance see the [Championship Record Claim Form](#)

E2 ECONOMY & DISTANCE

Task type: Economy

Objective

To take off from the deck with a given quantity of fuel ²¹, fly as many sections as possible around a course of one or more sections and land in a landing deck.

Description

Each section must be approximately 1Km in length and must contain a landing deck. Lines of no return are arranged to prevent aircraft flying in the reverse direction to the general flow of traffic.

The pilot waits to start the task in the takeoff area as briefed.

A **green flag** will be waved to indicate the pilot must start the task.

Pilot enters the course and tries to fly as many sections as possible before landing in one of the landing areas.

Pilots must not exceed 200ft height at any time.

Pilots should overtake on the outside of the course, they may overtake on the inside but will not score that section if the manoeuvre is considered to be overly aggressive.

Penalties

No section score

- Overly aggressive overtaking.
- Flying too high.
- Failing to pass a pylon.

5 sections

- Failure to land in a landing deck.

Last place:

- Pilot or any part of his Paramotor touches the ground during the task and takes off again.

Scoring

Pilot task score = Pilot number of sections completed - pilot penalties. (most sections is best).

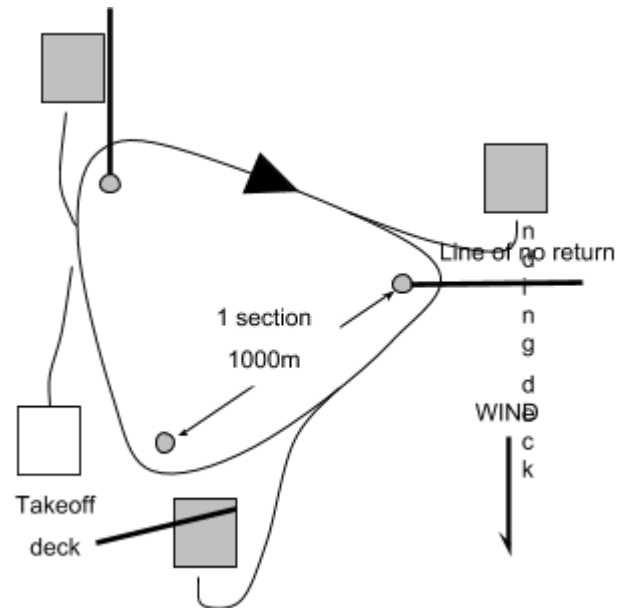

²¹ If the '5 minute rule' is invoked; LR 12.6.1, the pilot may not refuel and the section count restarts at zero at repeat takeoff.

E3 ECONOMY & NAVIGATION**Objective**

To take off with a given quantity of fuel and locate an unknown number of markers within defined sectors and return to the deck.

Description

Each sector will contain a given IP (initial point) and a FP (finishing point) which may be a turn point, marker or gate. The pilot flies a given track between the IP and FP. An unknown number of markers may be distributed along the track.

Penalties

Last Place:

- Unobserved takeoff
- Outlanding

Scoring

Pilot task score = The number of ground markers and/or turn points a pilot collects in the task

E4 SPEED TRIANGLE & OUT AND RETURN**Objective**

With limited fuel, to fly around a circuit in the shortest possible time, return to the deck, and then, with the pilots remaining fuel, fly in a given direction as far as possible and return to the deck.

Description

Teams proceed to the fuel control area to do the fuel control procedure.

Free take-off within the takeoff window.

Pilot flies through the IP1 gate to start the clock for part 1, the speed triangle.

- If the pilot flies repeatedly through this gate, the LAST time is the time taken.

Pilot flies around the triangle, passing through the scoring zones of the two turn points on the way, and flies through the FP1 gate.

Pilot performs the '4 sticks' task

Pilot flies through the IP2 gate to stop the clock for part one and to start part 2, the out and return.

Pilot flies to a point of his own choice anywhere within the bounds of the official map and returns to the landing deck.

The distance measured is the total straight line distance from FP2 to the point of maximum distance and back to FP2.

Upon landing, all pilots must proceed immediately to the fuel tank and flight recorder checks.

The four sticks

4 standard slalom poles are set at the corners of a 50m x 50m square. The pilot must kick 3 of the 4 poles. The first pole the pilot kicks may be any of the 4 poles. The third pole the pilot kicks must be diagonally opposite the first, the second pole may be either of the two other poles.

The pilot may have as many attempts as necessary at striking the first pole, Only ONE attempt is allowed at kicking both the second and third poles.

There will be two groups of poles. If, in the opinion of the marshals on duty a conflict with another aircraft exists in the same group, and the other group is also occupied, then a red flag will be waved and both pilots should kick only one pole and then depart on the rest of the overall task. Both pilots will then be given the opportunity to have ONE further attempt at this task as soon as possible after the end of the overall task.

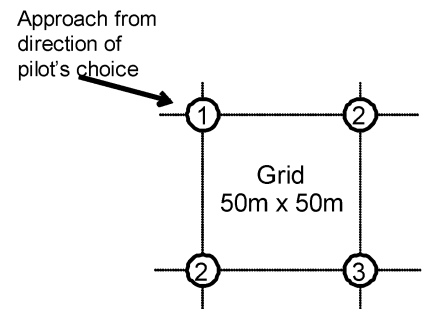
**Penalties**

Zero part 1 score

- Missing one turnpoint in part 1.
- Failing to pass through the IP1 or FP1 gates in the correct direction.

Zero part 2 score

- Failing to pass through the IP2 or FP2 gates in the correct direction.
- Land out before completing part 2.

Zero task score

- Land out before completing part 1.
- Missing both turnpoints in part 1.
- Takeoff, or return through the FP2 gate outside the task window.
- Flight in a no-fly zone.

Scoring

$$\text{Pilot score} = \left(475 \times \frac{tMin}{tp}\right) + Nq + \left(475 \times \frac{dp}{dMax}\right)$$

Where:

tp = the pilot's time, $Tmin$ = The best time (Part 1)

dp = the pilot's distance, $dMax$ = the greatest distance (Part 2)

Nq = 10 points for kicking one stick, 25 points for two or 50 points for three.

N1 PURE NAVIGATION

Task type: Navigation

Objective

To fly a course between as many turn points or markers as possible within the time window and return to the deck.

Penalties

Zero task score

- Failure to cross the IP or FP gates in the correct direction.
- Takeoff, or return through the FP gate outside the task window.
- Land out.
- Flight in a no-fly zone.

Scoring

$$\text{Pilot score} = 1000 \times \frac{\text{NBp}}{\text{NBmax}}$$

Where, according to briefing;

Either:

NBp = The number of ground markers and/or turn points a pilot collects in the task

NBmax = The maximum number of markers and/or turn points collected in the task

OR

NBp = the distance flown by the pilot in the task.

NBMax = the maximum distance flown in the task.

N2 NAVIGATION / ESTIMATED SPEED

Task type: Navigation

Objective

To fly a course between any combination of turn points and gates as defined at the briefing having declared estimated flight times or estimated times of arrival as required at the briefing, and return to the deck.

Special rules

- The value of T, in seconds, will be given at the briefing.

Penalties

Zero task score

- Failure to cross the IP or FP gates in the correct direction.
- Takeoff, or return through the FP gate outside the task window.
- Land out.
- Flight in a no-fly zone.

Scoring

$$\text{Pilot score} = \left(700 \times \frac{\text{NBp}}{\text{NBMax}} \right) + (300 - T)$$

Where, according to briefing;

Either:

NBp = The number of ground markers and/or turn points a pilot collects in the task

NBmax = The maximum number of markers and/or turn points collected in the task

OR

NBp = the distance flown by the pilot in the task.

NBMax = the maximum distance flown in the task.

AND

T = The total difference in between pilot's estimated and actual times for all timed sectors. ($\geq 300 = 300$)

N3	CURVE NAVIGATION
-----------	-------------------------

Objective

Precisely fly the course defined by an arbitrary line drawn on the map, with time estimations and a time limit.

Planning

A course will be defined by a start (SP) and finish (FP) points and a line drawn on a map, with a small number of intermediate timing gates (TG). All TG points will be known before take-off.

Pilots will fill in a declaration sheet indicating their estimated times of arrival to every TG in the circuit, including the finish point. Estimated times will be given in seconds counted from SP. Planning may be done in quarantine, or not, according to the briefing. Pilots will hand their declaration to a marshal before take-off.

Take-off

Pilots must hand their declaration sheet to the marshal before take-off. Unless otherwise briefed, pilots will perform a free launch from their designated deck.

Flight

Time will start when the aircraft crosses the start point. Then pilots will precisely fly the course trying to cross the time gates in order at their estimated times. Navigation and timing end at the finish point.

There will be an undetermined number of hidden gates to validate the course. Gates must be crossed in order and proper direction. Crossing the same gate more than once in any direction invalidates the gate. Example: The sequence 1-2-4-3-5-6-5-7 will be evaluated as 1-2-4-6-7, a total of five correct gates.

Time will be measured at five known time gates (TG) and checked against pilot declarations. If a time gate is crossed more than once, time will be extracted from the first crossing. There will be a small bonus for speed along the whole course, that may include planning time if briefed.

Scoring

Hidden gate score

N_h = Number of hidden gates in the task

H = Number of hidden gates correctly crossed (crossed once, in order and proper direction) $Q_h = 900 \times H / N_h$

Known time-gate score (when the course includes known time gates). An expected time of arrival (ETA) to each gate will be calculated based on the pilot's declaration. The difference between the ETA and the real crossing is the time error for a gate.

E_i = Absolute error in seconds in gate i with a tolerance of 5 seconds and a maximum of 180. $H_i = 180 - E_i$ (Points obtained in gate i). Time gates not crossed score zero.

$Q_t = \sum H_i$ (Sum of points from all five timing gates, maximum 900)

Speed score

T_{start} = Time of crossing SP or time when the pilot starts planning (according to briefing) T_{fin} = Time of crossing FP

$T = T_{fin} - T_{start}$

T_{min} = Minimum time in the class

$Q_v = 200 \times T_{min} / T$

Total

$Q = (Q_h + Q_t) \times (1 + Q_v / 1000)$ $P = 1000 \times Q / Q_{max}$

Task-specific penalties

Up to 100% penalty for backtracking, as defined at the briefing.

20% penalty for an excessive delay between effective take-off and crossing the start point.

DECLARATION SHEET

The following declaration sheet may be used in task N2 and N3.

Time Gate	Estimated time of arrival in seconds counted from the start point (SP)
SP	0s
FP	

PILOT NAME

BIB No.

Team

Class

Date

Task No.

Pilot's Signature