



*Fédération  
Aéronautique  
Internationale*

---

# Minutes

of the  
**2019 Plenary Meeting of the  
FAI Microlight and Paramotor  
Commission (CIMA)**

Held on  
**Friday 22 November to Saturday 23 November 2019**

**From 0900 to 1700**

At  
At Ramada Majestic Hotel  
Bucharest (ROM)

**Version 1 - 28/11/2019**

*Maison du Sport International  
Av. de Rhodanie 54  
CH-1007 Lausanne  
Switzerland  
Tél. +41 (0)21 345 10 70  
Fax +41 (0)21 345 10 77  
E-mail: [info@fai.org](mailto:info@fai.org)  
Web: [www.fai.org](http://www.fai.org)*

## Contents

1	Welcome and Administrative Matters.....	3
2	Report of the FAI .....	4
3	CIMA Bureau report on activity since the last plenary .....	6
4	Delegate Reports .....	8
5	Reports on the 2019 Championships .....	8
6	Championships 2020 – Bids to be granted final approval.....	8
7	FAI Championships 2020– bids to be confirmed .....	11
8	FAI Championships 2021 and 2022 – Provisional Bids .....	11
9	Other Championships 2020 -2022 .....	12
10	FAI Championships beyond 2020-2022 .....	12
11	FAI Air Games .....	12
12	Update on FAI IT services.....	13
13	Working Group Reports.....	14
14	Committee Reports .....	15
15	Reports from delegates in expert groups and commissions .....	18
16	Honours, medals, and awards .....	18
17	CIMA financial report and budget.....	19
18	Any other business.....	21
19	Election of Officers .....	21
20	Calendar .....	22
21	Annexes .....	23

## **1 Welcome and Administrative Matters**

The CIMA President opened the meeting.

### **Roll-Call**

No apologies for absence

6 valid proxies have been received by FAI head office.

Spain (ESP) to Great Britain (GBR)  
Denmark (DEN) to Norway (NOR)  
Egypt (EGY) to Germany (GER)  
China (CHN) to Poland (POL)  
Lithuania (LTU) to Romania (ROU)  
Netherlands (NED) to Belgium (BEL)

19 countries represented in person by delegates:

Austria (AUT)  
Czech Republic (CZE),  
Germany (GER),  
Hungary (HUN)  
Great Britain (GBR)  
Poland (POL),  
Switzerland (SUI),  
Romania (ROU),  
Brazil (BRA),  
Norway (NOR),  
Belgium (BEL),  
France (FRA)  
Saudi Arabia (KSA),  
Italy (ITA)  
Japan (JPN)  
Portugal (POR)  
Qatar (QAT)  
Sweden (SWE)  
Slovakia (SVK)

19 countries and 6 proxies: total 25 votes

Simple majority = 13

2/3 majority = 17

### **Agenda**

Approval, sequence, amendments.

AOB:

Microlight Committee Ann Welch Diplomas

System for delegates to recommend officials

Voting on official response of CIMA plenary to FAI budget.

**Conflict of interest**

Wojtek DOMANSKI (POL) is involved in the manufacture of paragliders for motors.  
Daniel SPRING (SUI) is involved in the manufacture of gyrocopters  
Krzysztof ROMICKI (POL) is involved in the manufacture of paramotor trikes

**Minutes from 2018 CIMA meeting**

CIMA Secretary Barney TOWNSEND reports no matters arising. No further comments made from the plenary.

Proposed GBR, Seconded SUI

Vote	For	Against	Abstain	Approved?
Votes to accept the minutes of 2019 plenary as true and accurate	24	0	0	YES

**Matters arising**

Nomination forms for CIMA elections were distributed at this point. Elections will take place for bureau and other positions towards the end of the meeting.

<b>2 Report of the FAI</b>
----------------------------

**FAI Report presented by Markus HAGGENEY (Annex 1)**

This is a pre-report to the FAI general conference now that GC had to be moved to December.

**2.1 FAI GC**

Unfortunately this could not be held in Morocco as originally planned.  
Website and all details at <https://www.fai.org/gc2019>

**2.2 Budget 2020**

FAI is in a challenging financial position. Lost revenues, changes in membership classe and the termination of the Red Bull Air Race as a very important activity in FAI leave a gap of approx €700k for 2020.

Delegates are invited to ready the FAI President's musings documents online, and also the annexes provided in the cloud for the FAI General Conference scheduled for 5/6.12.20219 in relation to budget.

The FAI executive board have presented a proposal in how to address the financial challenges, which commissions have been active in discussions on.

Proposals include:

- 1) Reduce office costs
- 2) Every sporting license holder pays 15 SUI for 2020
- 3) Increase sanction fees and record fees

FAI Central projects were hiding a structural deficit which had existed for more than 10 years in that expenditure was exceeding income. We are now in a critical situation that hopefully will prompt all of us to work together to resolve the situation.

Extra expenditure includes: Air Games Series, TV production, More FAI staff members, Consultants

Bob Henderson is working extremely hard to resolve the situation.

Note from Rob HUGHES (CIMA 2VP).

Cash asset value of FAI has dropped from 2.8m to 1.3m (of this, 1m belongs to commissions and 0.3m belongs to a prize trust) so FAI bank is essentially empty. We have to ask what value we have gained from this extra expenditure and investment? It seems like there is very little gain.

This is a crisis situation. Board has made large cuts already but it has lost the big sponsorships.

EB proposed to make about 150k in cuts but raise more money from the commissions to be able to continue the same spending pattern. They want to raise:

250k from sporting licenses

20% tax on commission funds.

Major FAI project has been to spend a huge amount on TV, but we don't have a TV ready product yet.

The same day Red Bull announced withdrawal of sponsorship FAI announced they were going to employ another person.

Commission presidents and NACs have been talking and are generally agreed that they need to insist the FAI cut spending – about half of all votes at the GC are agreed to give message that their budget for 2020 is wrong.

A lot of trust has been eroded between EB and the commission presidents so there is no goodwill left.

Presidents have 44 votes. NACs we speak to will also vote no.

We need this commission to send the message to the board:

We disagree with you

We can't see why the provision is better for the extra 500k spending.

We need EB to cut the budget.

In 2015 the GC voted to approve spending on the air games series, on condition that a certain income would result from it. There is still no income reported on and no indication of what the benefit from the expenditure has been.

Proposal – establishment of a working group to examine and develop our media "product".

### **2.3 WAG2022**

Dates were moved from 2020 to 2022. Concept has been changed to a collection of World Championships that are all Cat.1. Commission sanction fees are as normal.

ASC liaisons have all made venue visits; report from Rob Hughes will be presented later in the agenda.

Relevant documents from FAI are on the cloud for the FAI General Conference 2019 at the FAI website.

### **2.4 Anti-doping**

There is a new president of CIMP, Dr. Marja Osinga from Netherlands. FAI is represented at WADA conference and have regular contact with the WADA office. This association is a positive story for publicity.

The focus is on trying to keep testing activities to competition only to reduce the burden on competitors.

WADA and National Anti-Doping Agencies can show up at any of our events they choose without announcement and pilots should be aware of this.

Ensure pilots are aware and use Therapeutic Use Exemptions (TUE) if necessary. Penalties are very significant for the athlete, their national federation and the whole federation.

For questions contact FAI anti-doping manager Segolene Rouillon through [antidoping@fai.org](mailto:antidoping@fai.org).

The presentation from Markus HAGGENEY is included in **Annex 1**

### **3 CIMA Bureau report on activity since the last plenary**

#### **3.1 Report from CIMA president Wolfgang LINTL**

FAI is in a difficult position as we have heard and we will need to vote to define our official position on this. We need to consider the effect on our activities if we have to send more money to FAI either from our reserves or from sanction fees or sporting licenses. I reject such plans, together with all the other commission presidents.

This is the second period that we have faced problems with our treasurer. Alf NIPE was elected last year but he was too busy professionally to commit to the role so the bureau released him and CIMA 1VP Rob Hughes has been acting treasurer. For the same reasons CIMA 2VP Nayot KURUKITKOSON has also been unable to participate actively in the bureau activities this year.

Another reminder for countries on bidding for championships according to our formally recognised procedure. Sometimes delegates raise their hands for interest in bidding but then do not follow through. This puts other countries off bidding, so please only do this if you are genuinely serious about holding the championship.

There is also a problem with lack of interest in this commission from many member countries who do not send delegates to the plenary meetings. Delegates are invited to contribute ideas for how to improve participation.

There was this year an appeal from Ukraine against a controversial jury decision at WMC2019. It was clear that there would be no change to the rankings as a result. Ukraine won the appeal based on the proposition that “all rules must be applied equally and fairly to all competitors” but it was also deemed to be a frivolous use of the official procedure.

On a positive note we should take pride in the enjoyment of our sport and continue the good work of sharing this and encouraging new pilots and organisers to participate.

The president's full report is included as **Annex 2**.

Points raised in discussion:

For countries in which there is limited budget available for attendance to plenary meetings, is there an opportunity for virtual participation through video conference etc. Some commissions have tried this but it is very difficult with more than 5 or 6 people. We can ask the question as to whether live streaming of the plenary is an option.

Wolfgang LINTL plans to approach some country representatives at the FAI GC to ask why they are not sending delegates.

The plenary noted thanks to the President for all of his ongoing hard work for the commission.

### **3.2 Competitions overview**

General report from Wolfgang LINTL.

Successful 15<sup>th</sup> EMC in 2019, but with less participants. Bureau made a decision to deviate from the S10 validation rule of 6 pilots / 4 nations. We might solve this by giving an exemption from the plenary to authorise the bureau to make this deviation in future.

Noted in discussion that the Gen Section already represents the absolute minimum that constitutes a valid and respectable championship, 6 is a very low number. An alternative solution would be to reduce the number of classes.

Part of the problem of participation is often in travel expenses for microlights. Is another solution to provide some assistance financially to countries that have the highest travel/transport costs?

Teams can buy extra medals but these come weeks after the event - can these medals be engraved on site at the event so that full teams can all get one to take home from the event?

Reports from jury members can be downloaded from the events section of the CIMA wiki.

### **3.3 Appeal on WMC2018**

Discussion of implications and action points for CIMA that arise from decision of FAI International Appeals Tribunal on appeal by NAC of Ukraine from WMC2018.

We have already been read the verdict. The report on the findings of the appeal and the decision of the tribunal are included in **Annex 3**.

CIMA and jury president need to learn the lesson that even in the spirit of generosity we must stick to the rules. We offered to set up a working group to assess these rules, to try to avoid a full and unnecessary tribunal when the outcome will have no effect on the rules. No proposals for S10 have been made by Ukraine this year for improvement of the rules.

The findings of the tribunal recommended that CIMA make the decision on what to do with the €3000 sanction fee. Options are: full reimbursement, partial reimbursement, or no reimbursement of Ukraine.

The bureau propose to return 50% of the fee to Ukraine and use the balance for development of our sport.

The point was raised that despite the recommendation of the tribunal, technically the Ukraine have had their appeal upheld and therefore in principle the procedure should be that their money is returned to them.

Vote	For	Approved?
Return total amount back to Ukraine	4	
Partial reimbursement 50%	13	YES
No reimbursement	7	

CIMA president to communicate decision to Ukraine.

#### **4 Delegate Reports**

Delegate reports are available on the CIMA wiki documents for 2019 Plenary at:

<http://wiki.fai.org/pages/viewpage.action?pageId=36307001>

Any delegates who have not yet submitted a report are requested to upload one.

Each delegate is asked if they have any issues arising from their reports to raise for discussion. No further issues were raised.

#### **5 Reports on the 2019 Championships**

##### **15th FAI European Microlight Championships, Lithuania**

President of International Jury: Wolfgang LINTL (GER)

Contest Director: Povilas KALINAUSJAS (LIT)

Report from: Wolfgang LINTL (GER)

A new director who was a bit inexperienced and needed some assistance at points but a foreign team ran the scoring which was excellent and very efficient.

Rob HUGHES (GBR) was remote jury member; he found it very difficult to make decisions and recommends that we abolish the option for remote jury.

This converse of this argument is that it may still be better to have a more experienced person who is remote jury rather than a less experienced one on site.

#### **6 Championships 2020 – Bids to be granted final approval**

##### **11<sup>th</sup> FAI World Paramotor Championships 2020, Brazil**

24<sup>th</sup> June - 4<sup>th</sup> July 2020, Linhares Flats, Brazil. Presentation from Barney Townsend (Monitor).



(Note at time of meeting the dates proposed were 10-20 June. These have since been amended).

The competition site and infrastructure were tested in 2019 by holding the Brazilian National Paramotor championships there. These were found to be satisfactory. In days before the plenary, the competition director raised concerns about having enough experience to run a world championship, and the organisers requested CIMA to consider a recommendation for another co-director for assistance at the event.

The first time for competition director doing a Cat1 comp can be problematic – we have seen this in the past. The plenary contributed suggestions for potential directors to approach; these will be contacted by CIMA secretary in forthcoming weeks.

The task catalogue and local regulations have been uploaded to the wiki, but they are still a bit rough because they have been translated from Portuguese, and we received them too late for delegates to be able to study them properly and for delegates to discuss with their pilots. But the organiser states that the TC will be standard 2020 version of S10 A4, only with slaloms removed.

The bid presentation is included in **Annex 4**.

Broadly speaking the plenary have confidence in the organisation of the championship. The Bureau propose that we grant a 2 week extension whilst a competition director is sought and final versions of the TC and LR are prepared. Then a further two weeks for pilots to read and feed back questions. So the following deadlines:

6<sup>th</sup> December: confirmation and publication of final TC and LR.

(Note from secretary: This deadline was met as LR and TC were published)

20<sup>th</sup> December: deadline for feedback from pilots / teams to bureau.

Final approval of the championship will have to be deferred to the bureau

Vote	For	Against	Abstain	Approved?
Defer approval of the TC and LR as per deadlines above.	25			YES

Vote	For	Against	Abstain	Approved?
Task CIMA bureau with final approval pending appointment of competition director	25			YES

### **Nominations of monitor and Jury**

Proposal from CIMA bureau:

Monitor: B TOWNSEND

Jury: Han Zhaofang (CHN), Richard Meredith Hardy (GBR), 3<sup>rd</sup> member TBC.

Vote	For	Against	Abstain	Approved?
Acceptance of bureau nominations for monitor and jury with task of bureau to find 3 <sup>rd</sup> jury member				YES

Steward: Belgium are interested in organizing a future championship, so it would be advantageous if a member of their organizing team served as a steward. Proposal for Ellen HYLEBOOS (BEL) to be further discussed.

**17<sup>th</sup> FAI World Microlight Championships 2020, Czech Republic**

August 2020, České Budějovice - letiště Hosín.

Presentation from Petr Jonáš is included in **Annex 5**.

The local regulations have been uploaded to the wiki. Task catalogue will be uploaded as soon as possible. Main change will be to allow carrying unlimited extra fuel in economy tasks, with aircraft weighed in and out to determine fuel usage.

The organisers invite a gathering of microlight pilots not competing to fly in for the opening ceremony.

Vote	For	Against	Abstain	Approved?
Award to approve and award the championship to CZE	24		1	YES

Vote	For	Against	Abstain	Approved?
Bureau to make final decision on 13 <sup>th</sup> December following review of TC and LR.	25			YES

**Nominations of monitor and Jury**

Proposal from CIMA bureau:

Monitor: Kristian DOLHAI (HUN) (2<sup>nd</sup> director at last European microlight championship).

Jury: Rob HUGHES (GBR - President), Wolfgang LINTL (GER), Vladimir SILHAN (CZE), 3<sup>rd</sup> member TBC

Steward: Michael KANIA (GER)

Vote	For	Against	Abstain	Approved?
Acceptance of bureau nominations for monitor and jury.	25			YES

**7 FAI Championships 2020– bids to be confirmed**

**4<sup>th</sup> FAI World Paramotor Slalom Championships – Czech Republic**

A late bid was received from CZE to host a World Paramotor Slalom Championship. The presentation is included in **Annex 6**.

Location is well positioned centrally in Europe and very good site. 6 days flying planned should be plenty to ensure a valid competition. Normal FAI point scoring methods proposed. Organisation Team is well experienced. The paramotor subcommittee feel confident that it will be a good competition.

The Czech bid does not specify what sort of timing system they will use. This should be checked and announced.

The task catalogue and local regulations have been uploaded to the wiki.

**Nominations of monitor and Jury**

Proposal from CIMA bureau:

Monitor: Krzysztof ROMICKI (POL)

Jury: Wolfgang LINTL (GER – president). Other 2 members TBC

Steward: TBC

Vote	For	Against	Abstain	Approved?
Acceptance of bureau nominations for monitor and jury, and power to bureau to select final members	25			YES

**8 FAI Championships 2021 and 2022 – Provisional Bids**

**FAI World Paramotor Championships 2021**

**FAI World Microlight Championships 2021**

**FAI European Paramotor Championships 2021**

**FAI Asian-Oceanic Paramotor Championships 2021**

No bids have so far been received

**Other FAI Continental championships; Americas**

No bids have so far been received

## **9 Other Championships 2020-2022**

### **World Games 2021**

Microlights and Paramotors will not be included in the World Games 2021.

Wat can we do to get microlights and paramotors included in this? We can lobby for it, but ultimately it is the local organisers who decide which are their priority sports so they will pick sports that are popular locally.

### **Asian Beach Games 2020: China**

November 28th to December 6th in Sanya

Report from Markus HAGGENEY. This is an important event that will take place but no further details are available yet. This is not an open event, ABG is probably open for only Asian Olympic Committee members.

## **10 FAI Championships beyond 2020-2022**

### **Classic World Championships 2022 & 2024**

World Paramotor Slalom Championship at FAI World Air Games 2022

Expression of interest from Saudi Arabia for WPC 2022

### **Slalom World Championships 2021 & 2023**

Expression of Interest from France and Spain for WPSC 2021.

### **Classic Continental Championships 2021 & 2023**

Expression of interest from Belgium and Portugal for EPC 2021

### **Slalom Continental Championships 2020 & 2022**

There is no information available for any of the above championships.

### **Paramotor Endurance World Championships 2021 or 2022**

Expression of interest from Great Britain.

## **11 FAI World Air Games**

### **5<sup>th</sup> FAI World Air Games 2022, Turkey**

Presentation is in **Annex 7**. Rob and Markus visited a new site in October. New site will be shared with other air sports, no longer alone. Flights will be over the long empty

Pamucak beach about 1km from hotels. Not many tourists. Flat sand with shallow shelving beach and flat water, no rocks. Some waves when onshore wind. Met says steady and calm winds throughout the year. Main base at Selcuk airfield a few km away with 1.8km runway. Ephesus historical site is nearby for tourism.

Would be a normal WPSC. We would provide the TC and LR, and list of requirements in terms of marshals etc. But it is not a normal WPSC in the sense that CIMA are organising it not the local team.

Some sports are running a “special event” not a world championship, so there will be some sports teams (i.e. paramotors) paying entry fees and others not.

There will be much more information available after the FAI GC in two weeks’ time. So Rob HUGHES proposes to do no more work on this until we have more news as to whether or not this event will go ahead at all.

We want to go to FAI CG with a clear message that CIMA are in support of running a championship.

Markus: The political situation in Turkey can be challenging and he gets many questions about this. But there is also a thriving tourism industry in Turkey. There are various contractual issues being addressed right now and hopefully we can have a clearer view on the way forward in early December.

Philosophy of running World Championships under World Air Games common banner brings benefits in branding. Host cities realise that there is excellent exposure and PR to be gained from a relatively small investment in this.

#### **Status World Air Games series and air sports developments**

Air games series concept has been discussed at length in the FAI financial document that has been circulated. This will be addressed as part of the air games concept.

(Note from secretary: since the plenary meeting, and following the FAI general conference, the 2022 World Air Games project has been cancelled).

## **12 Update on FAI IT services**

Report from Markus HAGGENEY (FAI) is included in **Annex 8**.

### **Competition Management System**

eNavigator by Noosphere (FAI IT Partner) have created a new automated competition management system, where pilots can self-register and create profiles. NACs can see it, pilots can generate automatic invitation letters etc. There is a paypal connection for people to pay fees.

Full access will be given to local organisers – there is a detailed presentation about how to do this available upon request from Markus.

### **Event Sanctioning Management System**

FAI runs 600 events a year. Tool uses same Noosphere technology to manage payment for events and automatically updates the FAI event calendar.

CIAM already use 95% of their events through this system.

### **Sporting License database**

Improvements are in progress at the moment – better search features, better management of duplicates, multiple sports on a single license.

### **Officials registration system**

CIAM has hundreds of officials and these are all now managed automatically in the same system. NACs can approve them in the same system. Officials have profiles that can show their expertise in relation to particular sports etc.

### **Other projects**

CIVL are working on an event management system and have invested €65k towards it.

FAI server space is available for commissions for storage of data like videos etc.

Online record claim forms – approx. 1 per day all year. This will add structure to this and streamline the process.

### **Report on Organizer Agreement**

Currently OAs are being circulated on paper but this is slow and not environmentally friendly. Electronic issuing and handling of organiser agreements is being worked on at the moment.

## **13 Working Group Reports**

---

### **IT Working Group**

Report was submitted online by Richard MEREDITH-HARDY for IT working group and New Technology working group; it is included in **Annex 9**.

The Wiki server has been moved to a modern WIN2016 one. There is a longer plan to upgrade the wiki software as well but this is a big job because several iterations are needed to get as far as the current version.

### **FAI New Technology Working Group**

Established September 2019 by EB, tasked to present a proposal for the FAI's GC 2021. Contains delegates from most commissions; Richard MEREDITH-HARDY represents CIMA. The objective is to investigate flight tracking technologies and recording methods.

A Czech developer is working on a new live tracking logger. There are 50 prototypes in use currently, some of which were tested at EMC2019 Lithuania, where they were highly successful. Recommendation of RMH is that we allocate some of the €10k fund already designated by CIMA towards logger development to assist with further testing of this product.

FAI new technology working group is more or less dormant because the people involved are very busy with other projects. There is an overlap in the models being used by other commissions to develop similar systems and we should investigate commonality. Markus HAGGENEY will provide further info

#### **World League Cup working group**

Report from Wojtek DOMANSKI (POL);

The World League Cup dates run annually from 1<sup>st</sup> October to 30<sup>th</sup> September.

- **Results 2019**

PF1 was the only valid class. Only just achieved the minimum required 4 competitions for validity. We hope that there will more events included in 2020 because it is probably from this ranking that selection for WAG2020 will be made. A total of 18 countries and 69 pilots competed.

Individual	Nation
1- Alex MATEOS (FRA)	1- France
2- Bartos NOWICKI (POL)	2- Poland
3- Lubos HALAMA (CZE)	3- Czech Republic

Full results are available on the CIMA wiki at  
<http://wiki.fai.org/display/cimaContinentalCup/WLC+Results+2019>

The presentation that was made is included in **Annex 10**.

- **Future evolution of WLC**

It is particularly important for countries to designate their national championships as open so that we can build the profile and number of events in WLC.

#### **Endurance Championship Working group**

Barney Townsend reported on 2nd successful application of this format in the British Open Paramotor Championships in 2019. Changes have been made and tested to make the rules fairer and safer to all pilots. As a result, BT has submitted his revised LR and TC as a replacement for S10 A8 this year.

The principal differences between this format and that which was originally proposed are that GPS is no longer permitted for navigation assistance, and pilots may only land and refuel in designated zones that are monitored by marshals – ensuring that there is no advantage to pilots who have large ground support teams.

The new documents can be found in **Appendix 11**.

---

## **14 Committee Reports**

### **Microlight Subcommittee – Petr JONÁŠ (CZE)**

Key points on the agenda:

Discussion over the direction the task catalogue should go in – should it be stricter for directors not to be able to deviate from?

A feedback session at the end of the Lithuania championship with pilots was useful because there are quite weak links otherwise between pilots and CIMA.

Discussed possibility to enable the use of radios during competition. General agreement that it is better for the sport not to use radios.

Possibility for central European microlight cup each year or throughout the year – enabling more practice opportunities during the year.

Finally the section 10 amendments were voted on.

The full minutes of the microlight subcommittee are included in **Annex 12**.

#### **Paramotor Subcommittee – Wojtek DOMANSKI (POL)**

Key issues discussed:

Discussed S10 and found that we liked Micheal Kania's proposal of a circle task – we propose to include it for paramotors as well.

We discussed the competition calendar. Since Slalom was elevated to Cat 1 we have opportunity to have two championships. We discussed and agreed that we can allow WPSC every year; not excluding continental but it makes the championships more attractive to pilots and organisers.

Problem of touching water or pylon during the slaloms. Present rules penalise them but these were written when slaloms were still held over ground. Pilot is still penalised in his time by this but it is very hard to accurately judge if a touch was made to penalise officially. So we recommend that a change is made to S10 as a formal proposal next year, and to recommend to WPSC2020 that they do the same thing.

There is an issue with electronic timing gates when on water because the photo cells misalign with each other when they are floating on moving platforms. Some championships have claimed to use electronics when actually timing is manual. Concluded that 1) organisers must declare in advance if timing is to be manual. 2) if manual, a minimum of 3 timers must be used and averaged out. We also would like to investigate a better solution; FRA have investigated and found that photo finish is the best option but this costs approx. €25k.

There is an issue with training centers for slalom – there are not many available in Europe.

The full minutes of the paramotor subcommittee are included in **Annex 13**.

#### **FRAC – Flight Recorder Approval Committee**

Last year we invited CIMA 2PV Nayot KURUKITKOSON to tender for development of such a device but this did not progress.

Concurrently there has been another device under development by a Czech team, which was tested in prototype form at the Microlight championships in 2019.

Richard MEREDITH-HARDY recommends that CIMA support the development of the Czech product.



Vote	For	Against	Abstain	Approved?
Vote to empower bureau to invest from the reserve already allocated as they see fit to support the development.	24			YES

### S10 Committee

S10 was amended for 2019 as per the voting at the 2018 Plenary. Since then some small editorial changes have been identified and reported by delegates but these were purely grammatical and so have been amended by S.10 editor without need for recourse to plenary. These changes will be indicated on the 2018 revision of S.10.

9 proposals for amendments to S10 were received in 2019. The full S10 Editors Report is included in **Annex 14**.

No.	Title	Class	Microlight Vote	Paramotor Vote	S10 committee vote	Approved?	Notes
1	Clarification of weight limitation for records	MICRO	NO	ABS		NO	
2	Increasing minimum speed for microlight and paramotor aircraft	ALL	Withdrawn	ABS			Editorial issue
3	Clarification to the exception on backtracking	ALL	YES	NO		YES With amendment (A)	
4	Addition of some definitions	ALL	YES	YES		YES	
5	Ordered Scoring for paramotors	PARA	ABS	YES		YES	
6	Removal of tasks from the microlight catalogue	MICRO	NO	ABS		NO	
7	New Microlight Precision Task - Circle	MICRO	YES	ABS		YES	
8	No Pure Economy for PL2 class	PARA	ABS	YES		YES	
9	Revision of S.10 A8 Endurance championships LR+TC	PARA	ABS	YES		YES	

### Amendment A (proposal 3)

It was discussed in paramotor committee and proposed to the plenary that the proposed new text be amended as follows:

“The only exception to this is within a radius defined by the distance from the centre of the turnpoint to the outermost point of intersection between the two corridors”

This was approved by the plenary. The following illustrative diagram will be incorporated into S.10.

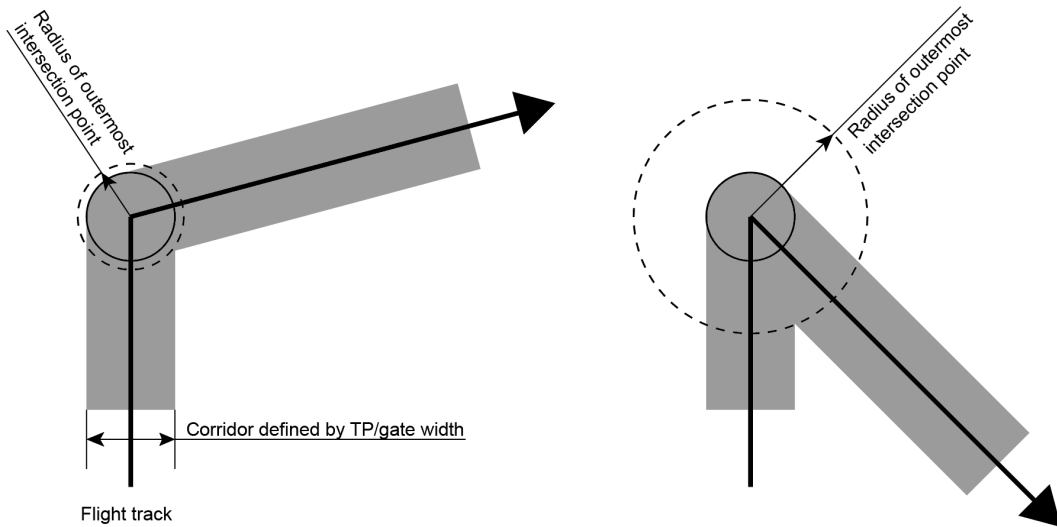

## 15 Reports from delegates in expert groups and commissions

### CIMP – Wolfgang LINTL (GER)

The report on CIMP from Wolfgang is included in **Annex 15**.

### ENVC – Tom GUNNARSON (USA)

It is a very small commission and they try to do things but there is very little action. There is nothing significant to report for CIMA at the moment.

A report has been submitted and is available in **Annex 16**

## 16 Honours, medals, and awards

### Colibri Diploma

No nominations have been received by FAI for the Colibri Diploma

### Ann Welch Diploma

A diploma is available for records set in both Microlights and paramotors. The dates for consecutive year's consideration run from plenary to plenary.

For paramotors, the following pilots were eligible:

Aleksander Hirsztritt (POL), PL1, Altitude 6377m  
(Previous record 5703m, 2017, 11.8% change)

Karen Skinner (ESP), PF1f, Distance over a closed circuit without landing, 309.93km  
(Previous record 130.3km, 2011, 137% change)

Krzysztof Romicki (POL) and Wojciech STRYZAKOWSKI (POL), PL2, Distance in a straight line without landing, 427.07km  
(Previous record 406.99km, 2018, 4.9% change)

**The plenary therefore accepted the recommendation of the paramotor subcommittee to award the 2018 Ann Welch diploma for paramotors to Karen SKINNER (ESP).**

For Microlights, following pilots were eligible:

Sanjeev KUMAR (IND), RWF1, Distance in a straight line without landing, 465.33km  
(Previous record 313.13km, 2012, 48.61% change)

Tomfii IAKOVLIEV (UKR) and Roman HUZII (UKR), Distance in a closed circuit with limited fuel, 209.9km.  
(Previous record 202km, 2012, 3.91% change)

Yuriy YAKOVLYEV (UKR) and Anna IAKOVLIEVA (UKR), Distance in a closed circuit without landing, 1022.67km.  
(Previous record 616km, 2000, 66.02% change)

Yuriy YAKOVLYEV (UKR) and Anna IAKOVLIEVA (UKR), Distance over a closed circuit of 1000km (121.1km/h, new record)

David BROOM (GBR), Distance in a straight line without engine power (34.54km, new record)

**The plenary voted to award the 2019 Ann Welch diploma for microlights to David BROOM (GBR).**

#### **World League Cup**

Medal results are presented above and full results are available on CIMA wiki.

Diplomas will be sent to NACs business for bureau / FAI.

#### **Other Award Business**

None.

## **17 CIMA financial report and budget**

### **Status of Financial Situation**

Report from Rob HUGHES (GBR) on behalf of absent treasurer. The treasurer's report is included in **Annex 17**.

Issues:

We had a new treasurer last year who was unable to fulfil his role for personal reasons. The commission thanks Rob HUGHES for taking the role of acting treasurer.

A number of key outstanding debts have now been paid this year.

#### **2018 accounts:**

2018 Opening bank balance: €67,964

Income for 2018: €7,455

Operating expenses: €2,385

Competition expenses: €11,512

Net result: - €6,642

2018 Closing bank balance: **€61,522**

This included a couple of exceptional items which when removed reduce the net loss significantly.

**2019 accounts to date:**

Income €4,519

Operating expenses: €2,529

Competition expenses: €1,329.60

Net result: €660.40

2019 current bank balance: **€62, 182.40**

Commission should note that we conduct our business in € but the officially audited accounts are in SUI so there will be some small discrepancies in the exchange rates.

**Approval of 2019 accounts**

<i>vote</i>	For	Against	Abstain	Approved?
Vote to approve 2019 accounts with future corrections by new treasurer	25	0	0	YES

<i>vote</i>	For	Against	Abstain	Approved?
CIMA president rejects FAI EB proposed budget at the FAI GC	23	0	2	YES

**Approval of 2020 budget**

Budget submitted to FAI in June 2019.

Income: €11,500

Operating expenses: €3,141.90

Competition expenses: €4,910

Net result: €3448.08

End of year balance: €65,630.50

<i>vote</i>	For	Against	Abstain	Approved?
Vote to approve the 2020 budget	25	0	0	YES

**2021 Budget – discussion**

We have 2 programmes of reserve figures:

Loggers: up to €10k.

IT Maintenance: up to €3k.

We should be aware of the overall FAI financial situation which might include:

20% 'tax' on sanction fees

20% 'tax' on CIMA reserves

It will be a decision for CIMA at some point whether or not to put this increase in sanction fees onto the pilots or whether to lower our fees accordingly to keep the pilot fee the same.

Suggestion to increase the research budget for software and use it to share software with more teams to enable better training for all using software.

## **18 Any other business.**

### **CIMA History – Tom GUNNARSON (USA)**

Tom has begun a new space within the CIMA wiki for CIMA history. This is designed as a repository for information relating to CIMA history that is complementary to (not replication of) other information on the CIMA wiki – particularly with reference to the stories of the people and decisions that have shaped CIMA over the years. Gathering this information is a task that must be shared, and delegates are invited to contribute any information, documents, images that they have onto this page.

Tom's report is included in **Annex 18**.

The plenary thanks Tom for his continuing hard work and passion for compiling these important records.

### **Delegates request for AOB**

Delegates are strongly requested to be more proactive in finding officials for championships. Please discuss all year round with your pilots, retired pilots, and organizers in your country and plan to come to the plenary next year with some names in mind, of potential officials that you have spoken with and already agreed that in principle they are prepared to act as an official for championships.

There is some written material to help explain what the positions are. This will be circulated by the secretary

## **19 Election of Officers**

- a. CIMA President: Wolfgang LINTL (GER)
- b. 1st Vice-President: Rob HUGHES (GBR)
- c. 2nd Vice-President: Kristian DOLHAI (HUN)
- d. Treasurer: Endre MOLNAR (ROM)
- e. Secretary: Barney TOWNSEND (GBR)

- f. Paramotor committee: Wojtek DOMANSKI (POL)
- g. Microlight committee: Petr JONÁŠ (CZE)
- h. S10 Editor and committee: Barney TOWNSEND (GBR) (editor), Rob HUGHES (GBR), Kristian DOLHAI (HUN) Petr JONÁŠ (CZE) Aref AL-SHAMMARI (KSA).
- i. Flight Recorder Approval Committee (FRAC): Richard MEREDITH-HARDY (GBR) (chair), Krzysztof ROMICKI (POL), Petr JONÁŠ (CZE), Lukas BEHONEK (CZE).
- j. IT Working group: Richard MEREDITH-HARDY (GBR - chair), Krzysztof ROMICKI (POL), Barney TOWNSEND (GBR), Lukas BEHONEK (CZE).
- k. World League Cup Working group: Wojtek DOMANSKI (POL), Agust GUDMUNDSSON (ISL), Paap KOLAR (EST), Aref AL-SHAMMARI (KSA), Barney TOWNSEND (GBR).
- l. CIMA delegate to the FAI Medical Commission (CIMP): Wolfgang LINTL (GER)
- m. CIMA delegate to the FAI Environmental Commission (ENV): Tom GUNNARSON (USA)
- n. CIMA Historian: Tom GUNNARSON (USA)
- o. Endurance Championship working group: Barney Townsend (GBR – chair), Paap KOLAR (EST), Krzysztof ROMICKI (POL), Aref AL-SHAMMARI (KSA), Jana BOBKOVA (CZE), Toon HYLEBOOS (BEL).

## 20 Calendar

### Date and venue for next CIMA Plenary meeting

Meeting to be held in Lausanne

Initially proposed dates: 14-15-16 January 2021. This is problematic for countries bidding for final approval of 2021 championships because it is only a few months before the event and does not allow much time for attracting sponsors, etc.

Next year the GC is planned for 19-25 October.

New proposal: 19-20-21 November 2020.

Vote: Next CIMA plenary to be held in	For	Approved?
November 2020	11	YES
January 2021	9	
Abstain	3	

### Agenda deadline

45 days in advance of the plenary – **6<sup>th</sup> October 2020**. If delegates have items that they would like added to the agenda they should email them to the secretary in advance of this date.

**S10 Amendments Deadline**

45 days in advance of the plenary – **6<sup>th</sup> October 2020**. Delegates should upload their proposals to the CIMA wiki in advance of this date.

**Colibri Diploma nominations deadline**

60 days in advance of the plenary – **21<sup>st</sup> September 2020**. NACs should send their nominations to Segolene Rouillon at FAI (members@fai.org) in advance of this date.

<b>21 Annexes</b>
-------------------

Annex 1 – FAI presentation from Markus HAGGENEY

Annex 2 – CIMA President opening remarks

Annex 3 – Findings of the international appeal tribunal for NAC Ukraine on WMC2018

Annex 4 – Presentation from Brazil about WPC2020.

Annex 5 – Presentation from Petr JONAS about WMC2020.

Annex 6 – Presentation from Czech Republic about WPSC2020.

Annex 7 – World Air Games inspection visit report from Rob HUGHES.

Annex 8 – FAI IT report.

Annex 9 – CIMA IT working group and FAI New Technology working group report.

Annex 10 – World League Cup 2019 report

Annex 11- Proposed revision to S10 A8 Endurance Championship TC and LR

Annex 12- Minutes of Microlight subcommittee meeting

Annex 13- Minutes of Paramotor subcommittee meeting

Annex 14 – S10 Editors report

Annex 15 – CIMP report

Annex 16 – ENVC report

Annex 17 – Treasurer's report

Annex 18 – CIMA History report