



FAI Sporting Code Section 6

*Fédération
Aéronautique
Internationale*

Regulations for the Conduct of International Aerobatic Events

Part Two Glider Aircraft

Version 2010-2

*Avenue Mon-Repos 24
CH-1005 Lausanne
(Switzerland)
Tél.: +41(0) 21/345.10.70
Fax.: +41(0)
21/345.10.77
E-mail: sec@fai.org
Web: www.fai.org*

Effective 23rd February 2010



FÉDÉRATION AÉRONAUTIQUE INTERNATIONALE

Avenue Mon Repos 24, 1005 LAUSANNE, Switzerland

© Copyright 2009

All rights reserved. Copyright in this document is owned by the Fédération Aéronautique Internationale (FAI). Any person acting on behalf of the FAI or one of its Members is hereby authorized to copy, print, and distribute this document, subject to the following conditions:

- 1. The document may be used for information only and may not be exploited for commercial purposes.**
- 2. Any copy of this document or portion thereof must include this copyright notice.**

Note that any product, process or technology described in the document may be the subject of other Intellectual Property rights reserved by the Fédération Aéronautique Internationale or other entities and is not licensed hereunder.



FÉDÉRATION AÉRONAUTIQUE INTERNATIONALE

Avenue Mon Repos 24, 1005 LAUSANNE, Switzerland

RIGHTS TO FAI INTERNATIONAL SPORTING EVENTS

All international sporting events organised wholly or partly under the rules of the Fédération Aéronautique Internationale (FAI) Sporting Code¹ are termed *FAI International Sporting Events*². Under the FAI Statutes³, FAI owns and controls all rights relating to FAI International Sporting Events. FAI Members⁴ shall, within their national territories⁵, enforce FAI ownership of FAI International Sporting Events and require them to be registered in the FAI Sporting Calendar⁶.

Permission and authority to exploit any rights to any commercial activity at such events, including but not limited to advertising at or for such events, use of the event name or logo for merchandising purposes and use of any sound and/or image, whether recorded electronically or otherwise or transmitted in real time, must be sought by way of prior agreement with FAI. This includes specifically all rights to the use of any material, electronic or other, that forms part of any method or system for judging, scoring, performance evaluation or information utilised in any FAI International Sporting Event⁷.

Each FAI Air Sport Commission⁸ is authorised to negotiate prior agreements on behalf of FAI with FAI Members or other entities as appropriate, of the transfer of all or parts of the rights to any FAI International Sporting Event (except World Air Games events⁹) which is organised wholly or partly under the Sporting Code section¹⁰ for which that Commission is responsible¹¹. Any such transfer of rights shall be by "Organiser Agreement"¹² as specified in the current FAI Bylaws Chapter 1, para 1.2 "Rules for Transfer of Rights to FAI International Sporting Events".

Any person or legal entity which accepts the responsibility for organising an FAI Sporting Event, whether or not by written agreement, in doing so also accepts the proprietary rights of FAI as stated above. Where no formal transfer of rights has been established, FAI retains all rights to the event. Regardless of any agreement or transfer of rights, FAI shall have, free of charge for its own archival and/or promotional use, full access to any sound and/or visual images of any FAI Sporting Event, and always reserves itself the right to have any and all parts of any event recorded, filmed and/or photographed for such use, without charge.

¹ FAI Statutes, Chapter 1, para. 1.6

² FAI Sporting Code, General Section, Chapter 3, para 3.1.3

³ FAI Statutes, Chapter 1, para 1.8.1

⁴ FAI Statutes, Chapter 2, paras 2.1.1; 2.4.2; 2.5.2 and 2.7.2

⁵ FAI Bylaws, Chapter 1, para 1.2.1

⁶ FAI Statutes, Chapter 2, para 2.4.2.2.5

⁷ FAI Bylaws, Chapter 1, para 1.2.3

⁸ FAI Statutes, Chapter 5, paras 5.1.1; 5.5 and 5.6

⁹ FAI Sporting Code, General Section, Chapter 3, para 3.1.7

¹⁰ FAI Sporting Code, General Section, Chapter 1, paras 1.2. and 1.4

¹¹ FAI Statutes, Chapter 5, para 5.6.3

¹² FAI Bylaws, Chapter 1, para 1.2.2



FÉDÉRATION AÉRONAUTIQUE INTERNATIONALE

Avenue Mon Repos 24, 1005 LAUSANNE, Switzerland

Deliberately Blank



TABLE OF CONTENTS

1.	GENERAL RULES FOR WORLD AND CONTINENTAL AEROBATIC CHAMPIONSHIPS AND INTERNATIONAL AEROBATIC COMPETITIONS FOR GLIDER AIRCRAFT	1
1.1.	Aims Of Aerobatic Championships And International Aerobatic Competitions.....	1
1.2.	General Regulations	1
1.2.1.	Contest Categories.....	1
1.2.2.	Aircraft Categories.....	2
1.2.3.	Number of Competitors	2
1.2.4.	Team Composition	2
1.2.5.	Entries	4
1.2.6.	Aircraft Documentation.....	4
1.2.7.	Air Safety	4
1.2.8.	Insurance.....	4
1.2.9.	Competitors and Aircraft.....	5
1.3.	Classification Of Aerobatic Contests	5
1.3.1.	World Championships “UG” and “AG”.....	5
1.3.2.	Continental Championships and International Competitions	6
1.4.	Contest Bodies	6
1.4.1.	The International Jury.....	6
1.4.2.	Board of Judges	7
1.4.3.	Contest Management	7
1.4.4.	Technical Commission	8
1.5.	Protests	8
1.6.	Final Regulations.....	8
1.6.1.	Interpretation	8
1.6.2.	Competitors' Pledge	9
1.6.3.	Supplementary Rules	9
2.	JUDGING RULES FOR GLIDER WORLD AND CONTINENTAL AEROBATIC CHAMPIONSHIPS AND INTERNATIONAL AEROBATIC COMPETITIONS	10
2.1.	Board of Judges	10
2.1.2.	Representation on the Board of Judges.....	10
2.1.3.	Qualification of Judges.	10
2.1.4.	The Chief Judge	11
2.1.5.	Composition of the Board of Judges	11
2.1.6.	Timekeepers and Evaluators.....	12
2.1.7.	Position of Judges	12
2.1.8.	Role of Judges.....	12
2.1.9.	Judges' Assistants.....	12
2.1.10.	Control of Timing	12
2.2.	Boundary Judging.....	13
2.2.1.	Electronic Tracking Instrument.....	13
2.2.2.	Line Judges	13
2.3.	Judging Administration	13
2.3.1.	Collection of Marking Sheets.....	13
2.3.2.	Publication of Results.....	13
2.3.3.	Public Announcements.....	14
2.3.4.	Protests, Decisions of International Jury, Confidentiality	14
2.3.5.	Procedure for the Mark of Zero	14
2.3.6.	Reprimand and Disqualification of Judges.....	14
3.	DUTIES OF THE INTERNATIONAL JURY	15
3.1.1.	Meetings	15
3.1.2.	Supervision.....	15
3.1.3.	Mediation	15
3.1.4.	Organiser's Responsibility.....	16



4.	REGULATIONS FOR THE ORGANISATION OF GLIDER WORLD AND CONTINENTAL CHAMPIONSHIPS AND INTERNATIONAL AEROBATIC COMPETITIONS	17
4.1.	Administrative Arrangements	17
4.1.1.	Entry Fees	17
4.1.2.	Accommodation, Food and Medical Services	17
4.1.3.	Towing Aircraft and Crews	18
4.1.4.	Technical Services	18
4.1.5.	Interpreters	18
4.1.6.	Briefing.....	18
4.1.7.	Familiarisation Flights.....	18
4.1.8.	Sequence of Flights (Drawing of Lots)	19
4.2.	Operating Regulations	20
4.2.1.	Radiophones.....	20
4.2.2.	Meteorological Conditions	20
4.2.3.	Competition Flights.....	22
4.2.4.	Height Limitations	23
4.2.5.	Performance Zone.....	24
4.2.6.	Measures in Case of Mechanical Defects.....	25
4.2.7.	No Radio Procedure	26
4.2.8.	Video Recording	26
4.2.9.	In-flight Data Recording.....	27
4.3.	Programmes For World And Continental Championships.....	27
4.3.1.	Sequence of Programmes.....	27
4.3.2.	Known Compulsory (Programme 1)	27
4.3.3.	Unknown Compulsory Programmes 1, 2, 3 and Unknown Free Programme (Programmes 2, 4, 5 and 6)	28
4.3.4.	Free Programme (Programme 3)	29
4.3.5.	Allowed Figures “AG”	31
4.3.6.	Coefficients for the Programmes “UG”	31
4.3.7.	Coefficients for the Programmes “AG”	31
4.4.	International Competitions	32
4.4.1.	Programmes	32
4.4.2.	Winners and Placings.....	32
4.5.	Awards	32
4.5.1.	World and Continental Championships “UG” and “AG”.....	32
4.5.2.	International Competitions.....	32
4.6.	Wind Limits and Measurement.....	33
4.6.2.	Procedure for Measurement of Wind Speed and Direction by Airborne GPS	34
4.7.	The Aerobatic Performance Zone	35
5.	REGULATIONS FOR THE EVALUATION OF COMPETITION FLIGHTS IN INTERNATIONAL AEROBATIC EVENTS	36
5.1.	Evaluation of the Performance.....	36
5.1.1.	Judges	36
5.1.2.	Marks for Figures.....	36
5.1.3.	Calculation of Scores.....	36
5.1.4.	Marking of Positioning	37
5.1.5.	Harmony	38
5.2.	The Penalty Point and Devaluation System.....	38
5.2.1.	Infringements of Height Limits	38
5.2.2.	Infringements of the Performance Zone	39
5.2.3.	Programme Interruptions.....	39
5.2.4.	Violation of Training.....	40
5.2.5.	Failure to Appear	40
5.2.6.	No Wing Dip at the Beginning or End of a Programme.....	40
5.2.7.	Violation of Flight Regulations and Dangerous Flying.....	40
5.3.	Rules for the Marking of Figures.....	41
5.3.1.	Deductions.....	41



5.3.2.	Soft Zero	41
5.3.3.	Hard Zero	42
5.3.4.	Mix of Zeros	42
6.	CRITERIA FOR JUDGING GLIDER AEROBATIC FIGURES	44
6.1.	Preface	44
6.2.	Definitions	44
6.2.1.	Angle of Attack	44
6.2.2.	Angle of incidence	44
6.2.3.	Figure	44
6.2.4.	Manoeuvre.....	44
6.2.5.	Mark/Point/Score	44
6.2.6.	Plane of Flight.....	45
6.3.	Flight Path And Attitude.....	45
6.3.1.	Flight Path	45
6.3.2.	Vertical Attitude	45
6.3.3.	The 45 Degree Attitude	46
6.4.	Marking	46
6.5.	Summary	46
6.6.	Wind Correction	47
6.7.	The Two Basic Components Of Aerobatic Construction: Lines And Loops.....	48
6.7.1.	Lines	48
6.7.2.	Loops and Part Loops	50
6.8.	Aresti System (Condensed) Glider Families.....	51
6.8.1.	Family 1 – Lines and Angles	51
6.8.2.	Family 2.1 - 2.2 Turns.....	51
6.8.3.	Family 2.3 - 2.20 - Rolling Turns	52
6.8.4.	Family 3 – Combinations of Lines	53
6.8.5.	Family 5 - Stall Turns.....	53
6.8.6.	Family 6 – Tailslides	54
6.8.7.	Family 7 – Loops and Figure 8's	55
6.8.8.	Family 7.1 - 7.4 - Half-Loops With Rolls.....	55
6.8.9.	Family 7.5 - 7.6 - Full Loops.....	56
6.8.10.	Family 7.7 - 7.10 - Square, Diamond and Octagon Loops.....	57
6.8.11.	Family 7.19 - 7.22 - Partial 8's.....	58
6.8.12.	Family 7.23 - 7.30 - Horizontal 8's.....	58
6.8.13.	Family 7.31 - 7.38 - Combination 8's.....	58
6.8.14.	Family 8 – Combinations of Lines, Loops and Rolls	58
6.8.15.	Family 8.1 – 8.28 – Humpty Bumps	59
6.8.16.	Family 8.29 - 8.48 and 8.51 - 8.54 - 7/8 Loops, Reverse Half Cubans, 3/4 Loops, Half Cubans ..	59
6.8.17.	Family 8.49 - 8.56 - Multiple Looping Combinations	59
6.8.18.	Family 8.57 - 8.68 – Teardrops	59
6.8.19.	Family 9 – Rolls and Spins	60
6.8.20.	Families 9.1 and 9.13 - Slow Rolls and Super-Slow Rolls	61
6.8.21.	Family 9.2 - 9.8 - Hesitation Rolls	61
6.8.22.	Family 9.9 - Positive Flick Rolls.....	61
6.8.23.	Family 9.10 – Negative Flick Rolls	62
6.8.24.	Family 9.11 and 9.12 – Spins.....	62
6.9.	Positioning	63
6.9.2.	Optimal Placement of Figures	64
6.9.3.	Sequence Symmetry	64
6.10.	Harmony	64
7.	CODE OF PRACTICE FOR THE CHIEF JUDGE AND BOARD OF JUDGES AT WORLD AND CONTINENTAL AEROBATIC CHAMPIONSHIPS	66
7.1.	Chief Judge	66
7.2.	Hard Zeroes	67
7.2.2.	Hard Zeroes Given By The Majority Of Judges.	67



7.2.3.	Hard Zeroes Given By 50% Or Less Of The Judges	67
7.2.4.	Hard Zeroes – Fact or Perception	67
7.2.5.	Hard Zero Index (HZI)	67
7.3.	Height and Interruption Penalties	68
7.4.	The Judges	68
8.	STATISTICAL METHOD FOR PROCESSING SCORES	69
8.1.	The CIVA Fair Play System - Purpose	69
8.2.	Overview	69
8.3.	Pre-Processing	69
8.3.1.	Dealing with Hard Zeros and Missed Figures	69
8.3.2.	Identifying Figure Grades for Analysis	69
8.3.3.	Grouping Figure Grades for Analysis	70
8.3.4.	Confirmation of Hard Zero	71
8.3.5.	Treatment of Other “HZ” or of “AG” Grades	72
8.3.6.	Treatment of Soft Zero Grades	72
8.4.	Definitions	72
8.4.1.	The Basic Data Values	72
8.5.	Group Processes	73
8.5.1.	Normalisation of a Data Group	73
8.5.2.	Derivation of Fitted Values	73
8.5.3.	Assessment of Anomalous Grades	73
8.5.4.	Treatment of Anomalous Grades	74
8.5.5.	Second Normalisation of the Group	75
8.5.6.	Replacement of Missing Grades	75
8.5.7.	Assembly of Processed Grades by Pilot	75
8.6.	Sequence Processes	76
8.6.1.	Normalisation of Sequence Scores	76
8.6.2.	Derivation of Sequence Fitted Values	76
8.6.3.	Assessment of Sequence Anomalies	76
8.6.4.	Interim Final Sequence Score	77
8.6.5.	Second FPS Iteration and Final Sequence Score	77
8.7.	Process Summary	77
8.7.1.	The process carries out the following analytical steps:	77
8.8.	Judging Performance Analysis	78
8.8.1.	Ranking Index (RI)	78
8.8.2.	Low and High Scoring Anomalies	79
8.8.3.	Discrimination	79
8.8.4.	Hard Zero Anomalies	79
8.8.5.	Sequence Score Anomalies	79
9.	LIST OF FIGURES FOR PROGRAMMES 2, 4, 5 AND 6	81
9.1.	Family 1.1 To 1.7	81
9.2.	Family 1.12 To 1.15	82
9.3.	Family 2.1 To 2.19	83
9.4.	Family 5.1 STALL TURNS	84
9.5.	Family 6.1 To 6.2 Tail Slides	84
9.6.	Family 7.1 To 7.6	85
9.7.	Family 7.19 TO 7.26	86
9.8.	Family 7.27 To 7.34	87
9.9.	Family 7.37	88
9.10.	Family 8.1 To 8.4	88
9.11.	Family 8.13 To 8.18	89
9.12.	Family 8.31 To 8.40	90
9.13.	Family 8.41 To 8.46	91
9.14.	Family 8.47 To 8.52	92



9.15.	Family 9.1, Continuous Rolls	93
9.16.	Family 9.2, 2-Point Rolls	93
9.17.	Family 9.4, 4-Point Rolls	94
9.18.	Family 9.8, 8-Point Rolls	94
9.19.	Family 9.13, Super Slow Rolls	94
9.20.	Positive And Negative Flick Rolls	95
9.21.	Family 9.11 (Positive Spins)	96
9.22.	Family 9.12 (Negative Spins)	96
10.	RULES FOR THE USE OF ELECTRONIC HEIGHT MEASURING DEVICES (HMDs)	97
10.1.	Types of HMDs	97
10.2.	Functions of HMDs	97
10.2.1.	Overview	97
10.3.	Technical Characteristics	98
10.3.1.	Tolerances	98
10.4.	Operating the HMDs	98
10.5.	Pilot Procedures for the Use of the HMDs	98
10.6.	Malfunction or Failure of the HMD	99
10.7.	Mounting Brackets	99
10.7.1.	MHMD	99
10.7.2.	HHMD	100
10.7.3.	Remarks	100
11.	KNOWN COMPULSORY PROGRAMMES	101
11.1.	Unlimited Known Programme	101
11.2.	Advanced Known Programme	102
12.	RECORD OF AMENDMENTS	103



Deliberately Blank



- 1. GENERAL RULES FOR WORLD AND CONTINENTAL AEROBATIC CHAMPIONSHIPS AND INTERNATIONAL AEROBATIC COMPETITIONS FOR GLIDER AIRCRAFT**
- 1.1. Aims Of Aerobatic Championships And International Aerobatic Competitions**
 - 1.1.1.1. To establish the champions and the winners in the various programmes.
 - 1.1.1.2. To establish the overall champions and the overall winners.
 - 1.1.1.3. To establish the champion teams and team winners.
 - 1.1.1.4. To promote the sporting skill of aerobatic pilots of FAI member aero clubs and arrange competitive contests between aerobatic pilots of FAI member aero clubs, and to allow aerobatic pilots the maximum opportunity to demonstrate within the scope of the general rules their ability in competition with others.
 - 1.1.1.5. To promote and popularise aerobatics and to develop and foster friendly relations between aerobatic pilots of different countries.
 - 1.1.1.6. In pursuance of these aims and in case of dispute over the interpretation and application of these rules, and any other regulations for the conduct of aerobatic championships and competitions, a competitor shall be entitled to the benefit of reasonable doubt.
- 1.2. General Regulations**
 - 1.2.1. Contest Categories**
 - 1.2.1.1. World Championships
 - a) World Championships will be held every two years. The duration of World Glider Aerobatic Championships is recommended to be no more than 9 days between opening and closing ceremonies. Opening and closing dates should be selected so as to allow competitors to travel to/from the contest site on weekends.
 - b) A National Airports Control (NAC), or other legal entity, which has applied to be host and organiser will be entrusted with the organisation of World Championships pending approval by CIVA.
 - c) The organisers will provide conditions for entry and participation for any national FAI member aero club on equal rights basis, and will carry out the World Championships on the basis of the decisions and rules of the FAI.
 - d) Each NAC will be notified by the organiser, not later than 6 months before the beginning of the championships, of any general organisational conditions such as time, place, travel and visa formalities, entry forms, entry deadline, etc.
 - e) CIVA shall decide at the meeting which precedes a World Championships which FAI language(s) shall be used as the working language(s) both orally and in writing for all purposes for the duration of the championships.



1.2.1.2. Continental Championships

- a) Continental Championships may be held in years when there are no World Championships and in principle should not last more than 7 days.
- b) The championships shall be open to all FAI members of one of the continents: FAI members of other continents may be invited to compete, but not for the title of Continental Champion.
- c) In other respects rule 1.2.1.1 applies.
- d) Except where otherwise stated in CIVA regulations, the rules and regulations of World Championships should apply.

1.2.1.3. International Competitions

- a) Organisers will be a national FAI member aero club.
- b) International contests must be made known to the FAI for inclusion in the calendar of international events by October of the year preceding the contest.
- c) Any national FAI member aero club may be invited to participate in an international contest.
- d) It is recommended that programmes are arranged according to the rules and regulations of World Championships.
- e) Each participating national FAI member aero club will be notified by the organising aero club not later than 3 months before the beginning of the contest of any general organisational details and of details specifically relevant to the contest.

1.2.2. Aircraft Categories

- 1.2.2.1. World, Continental and International Glider Aerobatic Championships are only open to Gliders.

1.2.3. Number of Competitors

- 1.2.3.1. World and Continental Aerobatic Championships will be held or recognised as such if there are at least 15 competitors from at least 5 countries.
- 1.2.3.2. Events will be recognised as international competitions provided that there are at least 6 competitors from at least 3 countries participating.

1.2.4. Team Composition

1.2.4.1. World Championships

- a) National Airports Controls shall notify the organisers of a World Championships, not less than two months before it is due to start, of the number of competing pilots to be entered from their national aero club up to a maximum of eight (8). The organisers shall have the right, without reference to CIVA, to reduce this maximum number of pilots of each nation from 8 to 6 competitors. In this event the organisers shall at once notify NACs accordingly.



- b) Solo entries are allowed from NACs.
- c) The team of each NAC may include the following officials: 1 chief delegate, 1 team manager, 1 trainer, 1 doctor, 1 interpreter, and no more than 3 mechanics.
- d) Every competitor must be a member of his or her NAC and must be in possession of a valid FAI sporting licence.
- e) Every official must be a member of his or her NAC.
- f) The admission of observers depends on the facilities available and is subject to agreement with the organiser.

1.2.4.2. Continental Championships and International Competitions

The composition of teams and the number of members of a team will be fixed by the organiser.

- a) As a guide line, the following composition of a team is recommended: 6 competitors, 1 chief delegate, 1 mechanic, 1 trainer.
- b) For Continental Championships, the number of competitors of each NAC should be no more than eight (8).
- c) Every competitor must be a member of his or her NAC and must be in possession of a valid FAI sporting licence.
- d) Every official must be a member of his or her NAC.

1.2.4.3. Eligibility “AG”

- a) Pilots who have flown in an Unlimited World or Continental Championship for gliders during the year of an Advanced contest or in the preceding two years, will only be eligible to fly in the Advanced contest if they gained less than 60% of the maximum possible marks across the sequences they flew in the last Unlimited contest.
- b) The same applies to pilots who have flown in an Unlimited or Advanced international championship for powered aircraft, during the year of an Advanced glider contest or in the preceding two years.

1.2.4.4. Non-NAC Entries

- a) Organisers are also obliged to accept entries from FAI Applicants as described in paragraph 3.2.1 or Sporting Code, General Section.
- b) At their discretion, Organisers may accept further entries from pilots not representing their NAC. These entrants will be classified as “*Hors Concours (H/C)*”. They will pay normal entry fees, subject to the normal entry deadlines for the contest, and be treated as other competitors. In the event of time constraints, however, they can expect to be shifted in the order of flight or deleted from the flight programmes altogether at the discretion of the International Jury. H/C pilots will appear in the final results but will not be ranked or eligible for any awards or medals.



1.2.5. Entries

- 1.2.5.1. The official entry forms must be completed correctly and submitted to the organiser not later than requested by the organisers.
- 1.2.5.2. Every NAC must be notified of the address of the organiser not later than 6 months for World and Continental Championships, or 3 months for international competitions, prior to the beginning of the event. (See 1.2.1.1, 1.2.1.2 or 1.2.1.3)

1.2.6. Aircraft Documentation

- 1.2.6.1. All competing aircraft must meet the performance characteristics required for the kind of flight they will be undertaking. A valid aerobatic certificate of airworthiness or equivalent document issued by the competent aviation authority of the participant's country must be produced to the organisers for every contest aircraft.
- 1.2.6.2. Aircraft will not be admitted to the contest unless the appropriate documentation has been submitted to the organisers.

1.2.7. Air Safety

- 1.2.7.1. All competitors must observe and adhere to the regulations currently in force in the organiser's country for air safety as well as the special regulations in force at the contest aerodrome. To facilitate this, the organiser must ensure that an English translation of applicable rules, issued by the Aviation or Customs Authorities of the host country, is available in advance in a bulletin or on the competition website.
- 1.2.7.2. Any violation of the safety regulations in force may at any time render the offender liable to exclusion from the contest. No responsibility will be undertaken by the organisers for any such violation by competitors or others.
- 1.2.7.3. To enable the pilot to watch over his or her own safety, an accelerometer must be installed in each competing aircraft.
- 1.2.7.4. The Chief Judge may, with the agreement of two-thirds of the Board of Judges, exclude a pilot who is not flying safely or could cause an unsafe situation. This would apply from takeoff to touchdown.
- 1.2.7.5. Any competitor required to interrupt a competition flight due to danger of collision with conflicting air traffic or a bird, should be treated in the same manner as if a mechanical defect (paragraph 4.2.6) had taken place.

1.2.8. Insurance

- 1.2.8.1. The organisers will provide a promoter's liability insurance of an adequate sum against third party risks for the duration of the contest covering functional test flights, training and competition flights, in accordance with the legal requirements of the country in which the championships or competition is held. The organizers must further have insurance for damages to competition gliders, etc., caused by the organizer or his staff.
- 1.2.8.2. All competitors must produce evidence of adequate third party insurance valid for the duration of the contest and valid in the organiser's country. The organisers should specify in local regulations the amount of insurance cover regarded as adequate.



1.2.9. Competitors and Aircraft

- 1.2.9.1. All flights carried out by competitors at World and Continental Championships and international competitions must be made solo; this applies to competition flights and training flights.
- 1.2.9.2. Replacements of competitors at Championships and international competitions will be left to the discretion of the International Jury, but no such replacement will in any case be permitted less than 12 hours before the commencement of the first competition flight.
- 1.2.9.3. A contest aircraft may on the recommendation of the technical commission, and with the permission of the International Jury, be replaced at any time by another contest aircraft.

1.3. Classification Of Aerobatic Contests

1.3.1. World Championships “UG” and “AG”

At World Championships the following competition flights will be scheduled:

1.3.1.1. Programmes

- a) Programme 1: The Known Compulsory Programme
- b) Programme 2: The 1st Unknown Compulsory Programme
- c) Programme 3: The Free Programme
- d) Programme 4: The 2nd Unknown Compulsory Programme
- e) Programme 5: The 3rd Unknown Compulsory Programme
- f) Programme 6: The Free Unknown Programme

1.3.1.2. Champions

World Champions will be:

- a) **World Champion in the Known Compulsory Programmes:**
The competitor who gains the highest number of points in Programme 1.
- b) **World Champion in the Free Programmes:**
The competitor who gains the highest number of points in Programme 3.
- c) **World Champion in the Unknown Compulsory Programmes:**
The competitor who gains the highest aggregate number of points in Programmes 2, 4, 5 and 6.
- d) **Overall World Champion:**
The competitor who gains the highest total number of points in all the programmes flown.
- e) **World Champion Team:**
Will be that team with the highest total number of points in those Programmes which were flown by all the competitors, taking into account the three highest individual scores in that team.



- f) Awards will be given in compliance with paragraph 4.5.

1.3.1.3. Champions and Winners

- a) If weather conditions or technical reasons prevent the completion of all the six programmes, at least 3 programmes must be completed for the event to be valid as a World Championship. In this case, the Overall World Champion will be the competitor who gains the highest number of points in the programmes which have been completed, and also the World Champion in each programme will be the competitor who gains the highest number of points in those programmes which have been completed.

1.3.2. Continental Championships and International Competitions

- 1.3.2.1. Rules 1.3.1.1, 1.3.1.2 and 1.3.1.3 should be applied.

1.4. Contest Bodies

1.4.1. The International Jury

- 1.4.1.1. The International Jury is the supreme arbitration body of international aerobatic events and shall be responsible for:

- a) Interpreting the general rules, the judging rules and the general regulations of the contests;
- b) Supervising the activities of the Chief Judge and the Board of Judges; during judging, members of the International Jury must not remain in the vicinity of the International Judges;
- c) Supervising the technical commission;
- d) Dealing with protests from competitors.
- e) Overseeing the administration of the contest and ensuring that the organisers of international contests meet the requirements as stipulated in the checklist provided to the organisers for such events.

1.4.1.2. Appointment

- a) The International Jury at World and Continental Championships will be appointed by the FAI Aerobatics Commission (CIVA) and will consist of a chairman and at least 2 members with adequate reserves, who must be members of different national aero clubs. The Chief Judge shall be an advisory member of the International Jury and the Contest Director shall be adviser to it. The President of CIVA or one of the Vice Presidents will be chairman of the International Jury and will supervise its activities. Detailed Duties of the Jury are contained in Section 3.
- b) For World and Continental Championships the chairman of the International Jury can also be the chairman of the Glider Aerobatics Sub-Committee of CIVA, even if he or she is not President or Vice President of CIVA. Members of the International Jury can also be members of the Glider Aerobatics Sub-Committee of CIVA, even if they are not delegates or alternate delegates to CIVA and, if necessary, qualified persons nominated by the competing teams, under the provisions of the FAI Sporting Code, General Section 4.3.2.



- c) At International Competitions the jury will be appointed and guided by the organisers. If possible, each participating aero club should be represented in the jury, and the chairman should be a member of CIVA.

1.4.1.3. At least three members of the International Jury must be available to hear appeals or protests submitted by competitors.

1.4.1.4. Any decision taken by the International Jury by majority vote is final.

1.4.1.5. When the International Jury is taking a decision which concerns the team or a competitor of the same national aero club as a member of the International Jury that member of the jury shall abstain from voting.

1.4.1.6. The International Jury may temporarily vary any rules approved by the International Aerobatics Commission (CIVA) during a contest under the following circumstances:

- a) There is simple majority agreement within the International Jury, with no abstentions, when conducting a vote to introduce a temporary variation to the regulations, and
- b) There is two-thirds majority amongst the participating teams' Chief Delegates, with no abstentions, when conducting a vote to introduce a temporary variation to the regulations.

1.4.1.7. In the event that the rules of the Sporting Code are not adhered to at a World Championship, or if the International Jury is not provided with sufficient information to perform their duties in accordance with the rules, the International Jury may stop the contest until matters are remedied.

- a) If remedial action is not taken, the International Jury has the power to declare that the requirements of a World Championship have not been fulfilled in accordance with the rules and that the event has only the status of a World Competition. If this latter action is taken, the International Jury shall prepare a full report for submission to the next meeting of CIVA at which their decision shall either be endorsed or reversed.

1.4.2. Board of Judges

1.4.2.1. Details concerning the employment of the Chief Judge and the composition of the Board of Judges and the appointment and disqualification of its members are laid down in the "Judging Rules for Glider World and Continental Aerobatic Championships and International Aerobatic Competitions" (Section 2).

1.4.3. Contest Management

1.4.3.1. The Contest Director will be responsible for the regular and orderly performance of the contest. The Contest Director is responsible to the International Jury for the efficient administration of the contest.

1.4.3.2. The contest management will be composed of:

- a) The Contest Director,
- b) The Flight Director,
- c) The Chief Judge,



- d) The Chairman of the Technical Commission.

1.4.4. Technical Commission

- 1.4.4.1. The Technical Commission will be composed of 3 to 5 engineers or mechanics. CIVA compiles a list of capable engineers or mechanics nominated by the national aero clubs; written evidence as to qualification, experience and technical knowledge must be submitted by the national aero clubs. CIVA selects from the list of approved engineers and mechanics the members of the Technical Commission for World Championships; if possible, the selection of the members of the Technical Commission should be guided by the type of competing aircraft operated during the contest.
- 1.4.4.2. The representative of the organisers will be nominated as the Chairman of the Technical Commission.
- 1.4.4.3. The Technical Commission is responsible to the International Jury for the inspection of competing aircraft and of aircraft documentation; for certifying compliance with the airworthiness regulations of aircraft after inspection; for a qualified and objective inspection in case of defects of the technical equipment; and for finding the causes of defects which have occurred during the competition flights. The Technical Commission will advise and inform the International Jury on any points of technical importance.

1.5. Protests

- 1.5.1.1. Protests will be accepted from individual competitors and teams only. They will be dealt with in compliance with the FAI General Section of the Sporting Code, Chapter 5. All protests must be submitted to the President of the International Jury or Contest Director in writing, either directly or through a member of the jury, with a deposit, not later than two hours after the occurrence, decision or publication of results which causes the protest to be made. "Non-working" hours, as defined in local regulations for the specific championships or competitions will not be counted. Every protest must refer to the rule or rules to which it relates. The amount of the deposit shall be stated in the local regulations for the championships or competition. It should not exceed \$100.
- 1.5.1.2. The deposit will be returned if the protest is upheld. The International Jury may request the attendance of the protesting competitor if it considers this desirable. The decision of the International Jury is final.

1.6. Final Regulations

1.6.1. Interpretation

- 1.6.1.1. International aerobatic events will be carried out in compliance with CIVA Regulations and local regulations of the organisers.
- 1.6.1.2. Any differences arising during an event will be dealt with by reference to the above rules. For the interpretation of the text at championships, a standard version written in one of the official FAI languages (English, French, Russian, Spanish) shall be taken as the authority. CIVA will select one of the FAI languages as the basis for interpretation.



1.6.2. Competitors' Pledge

1.6.2.1. All competitors undertake, by signing the entry form, to comply with the General Section and Section 6 of the Sporting Code of the FAI and any local regulations made under rule 1.6.3.1.

1.6.3. Supplementary Rules

1.6.3.1. The organisers will, within the scope of the CIVA Regulations and the approval by CIVA, prepare such local regulations or specialized details as are relevant and necessary for clarification of organisational problems and duly distribute them to all FAI national aero clubs (see 1.2.1.1, 1.2.1.2, 1.2.1.3 and 1.2.7.1).

1.6.3.2. The technical and organisational preparations of World Championships will be checked by CIVA regarding their compliance with the general rules before the beginning of the event.

- a) Not less than 6 months prior to the World Championships, the organisers shall publish in the agreed FAI language(s) and send to national aero clubs which have indicated a preliminary intention to participate:
 - i) the local regulations containing only local operating procedures and administrative details including details of the aerodrome at which the Championships will be held.
 - ii) English translation of applicable rules issued by the Aviation or Customs Authorities of the host country.

1.6.3.3. Organisers must ensure that at the time of the formal opening of the championship all technical preparations are completed and all required personnel are available.



2. JUDGING RULES FOR GLIDER WORLD AND CONTINENTAL AEROBATIC CHAMPIONSHIPS AND INTERNATIONAL AEROBATIC COMPETITIONS

2.1. Board of Judges

2.1.1.1. Judging during World and Continental Aerobatic Championships and international aerobatic competitions will be carried out by an International Board of Judges in compliance with the following rules.

2.1.2. Representation on the Board of Judges

2.1.2.1. At World and Continental Championships judges will be invited to apply for selection, irrespective of their nationality, based on their previous RI performance data as recorded in the CIVA Judges Performance Database (JPD). New judge applications for those without International RI performance data can be made by NACs or individuals, but must be accompanied by current RI data produced by the FPS scoring system at a National Competition (not necessarily in their own country). These applications must be made by the deadline published by the President of CIVA in the year in which the Championships are to be held. Judges are subsequently selected in accordance with procedures established by CIVA. The selection process includes a ranking of judges by the RIs in the JPD from past Championships. Up to seven selected judges are considered to be CIVA Judges for whom no entry fees may be asked by the contest organisers. An additional three judges may also be allowed to participate but could be subject to an entry fee in exceptional circumstances. A maximum of two judges per NAC may be appointed. Final selection will be ratified by the Bureau of CIVA.

2.1.2.2. For international competitions, International Judges will be invited by the organizers

2.1.3. Qualification of Judges.

2.1.3.1. All International Judges selected for the Championships or invited by the organisers of International Competitions must have been approved by the International Aerobatics Commission (CIVA) of FAI and listed in the FAI official document to that effect. A judge may not be deleted from the International Judges list who has valid and acceptable JPD data listed in the previous five years. Should a Judge, who has existing acceptable JPD or who is new applicant, not be supported by their home Aero Club, he/she will be listed in the International Judges List, in an International Section. Their Nationality will be shown in brackets after their name.

2.1.3.2. To be a current FAI judge at FAI aerobatic championships, an FAI International Judge must additionally fulfil the following currency requirements:

- a) In the year in which the championship is held or during the previous calendar year, the judge must have either judged at a national or international aerobatic championship at appropriate class or flown in that level competition as a pilot, or served as an official team trainer whose duties include critiquing appropriate level team members.
- b) Before the championship is held, the judge must also have satisfactorily completed a study course on the current rules and regulations. This study course will be composed and administered by CIVA. It can either be completed in advance of the championship or on the contest site. The study course will be available no later than six months prior to the beginning of the championship.



- c) In addition, prior to the championship, the Chief Judge shall conduct an oral interview with each prospective International Judge. This interview will determine the judge's basic competency and knowledge of the rules. This examination shall include but not be limited to: judging criteria, familiarity with the Aresti System (Condensed), and the ability to immediately interpret complex figures and sequences. The Chief Judge will also insure that the judge is in possession of current regulations with appropriate translation if necessary. The International Jury, in conjunction with the Chief Judge, shall have the authority to disqualify any International Judge from the championship if it determines that the judge is continuously biased or not competent. This decision will be final and cannot be protested or appealed.
- d) If the minimum number of judges cannot be achieved by applying clause (b) above, the next preference in choice of judges will go to the FAI judge(s) whose currency most nearly matches those requirements.

2.1.3.3. If any judge(s) are not available and cannot complete their functions and the minimum of 7 judges are not present, the International Jury will use its discretion in filling the available slot.

2.1.3.4. If a substitute International Judge is appointed under 2.1.3.3 above, he shall only take his place on the Board of Judges at the start of the subsequent programme, and the marks of the departed judge for the programme he did not complete will be deleted.

2.1.4. The Chief Judge

2.1.4.1. For World Championships the Chief Judge will be selected and appointed by CIVA; he/she may not be a citizen of the organiser's country (exceptions to this must be accepted by CIVA).

2.1.4.2. For Continental Championships, the Chief Judge must be approved by CIVA.

2.1.4.3. In any case, the Chief Judge must be an International Judge listed in the FAI official record and must have previous experience of serving as Chief Judge at a national or international aerobatic championship (or a major national competition) run under FAI rules.

2.1.5. Composition of the Board of Judges

2.1.5.1. At World and Continental Championships and international competitions the International Board of Judges will be composed of:

- a) The Chief Judge;
- b) A maximum of 10 International Judges and 10 assistants and a minimum of 7 International Judges and 7 assistants for marking the quality of aerobatic manoeuvres and positioning if the electronic tracking instrument is not in operation. Up to 7 of these judging teams may be selected by the Bureau of CIVA as FAI Judges,
- c) Positioning judges for operating the electronic tracking instrument and for recording the violations of the prescribed performance zone, or 2 line judges for the conventional recording of infringements of the performance zone. Positioning or line judges, although recommended, are not mandatory for international competitions;
- d) The administrative secretary, supervised by the Contest Director, who will be in charge of the documentation of results and of the evaluation office.



- 2.1.5.2. All judges who wish to be represented on the Board of Judges will judge Programmes 1 to 6, provided that they have a qualified assistant as required in paragraph 7.4.1.1. Any judge who does not provide a qualified assistant will be excluded.
- 2.1.5.3. The International Jury may exclude a judge from the Board of Judges after the completion of any programme if that judge's Ranking Index deteriorates significantly from those established in previous programmes.
- 2.1.5.4. The positioning judges working at the electronic tracking instrument may be nominated by the organisers. The positioning judges, whether at championships or at international competitions, shall be supervised by members of the International Jury or their delegates. If an electronic tracking instrument is not operated, the work of the positioning judges and their supervision is organised on the same basis.
- 2.1.5.5. The administrative secretary of the Chief Judge will be nominated by the organisers.
- 2.1.6. Timekeepers and Evaluators**
- 2.1.6.1. The Chief Judge and his assistant will record the timing of flights, ideally an evaluator checking paperwork will be appointed.
- 2.1.7. Position of Judges**
- 2.1.7.1. The judges (under 2.1.5.1.b)) will be posted by the Chief Judge at positions appropriate for observing the competitors, the positions of the judges being at least 15 m apart. The distance of the positions of the judges from the end points of the x/y axes will be a minimum of 150 m and a maximum of 250 m.
- 2.1.8. Role of Judges**
- 2.1.8.1. The International Judges appointed for marking the quality of the manoeuvres will mark the manoeuvres and infringements of the lower and upper height limits in compliance with the judging rules. (See 7.3.1.1)
- 2.1.9. Judges' Assistants**
- 2.1.9.1. The assistant(s) has (have) the following tasks:
- Telling the judge prior to the performance the sequence of the figures, details of the various figures, and any other special features.
 - Recording the mark given by the judge for each figure and writing down into the marking sheet any remarks concerning the rating. Any amendment of record must be signed by the judge.
 - Giving general assistance.
- 2.1.10. Control of Timing**
- 2.1.10.1. Checking the time of super slow rolls will be the duty of the timekeeper assigned to the Chief Judge.
- 2.1.10.2. Recording programme interruptions, and giving penalty points for such interruptions or for infringements of the lower and upper height limits, and the infringement of penalty point rule



5.2.6.1 of Sporting Code concerning wing dipping at the start and end of programmes, will be carried out under the responsibility and control of the Chief Judge.

2.2. Boundary Judging

2.2.1. Electronic Tracking Instrument

2.2.1.1. If an electronic tracking instrument is operated, the position of the aircraft will be indicated by the instrument and recorded with indelible ink by one of the positioning judges (i.e. instrument observers) on the positioning sheet, which will immediately be signed by an International Judge appointed to this end by the International Jury. The evaluation will be made in the evaluation office using a special positioning table.

2.2.2. Line Judges

2.2.2.1. If an electronic tracking device is not operated and line judges are to be used, they shall be placed either side of the judges' position at the upwind and downwind corners of the performance zone. Line judges should, if possible, be international. If they are operated by the organiser, a permanent supervision must be provided by the International Jury.

2.2.2.2. Line judges will be supplied with radio transmitters to enable contact with the Chief Judge's workstation. Performance zone infringements will be reported in real time and noted both by the line judges concerned and at the Chief Judge's station.

2.2.2.3. Only box outs observed at the Chief Judge's workstation to be realistic will be taken into account on the Chief Judge's score sheet submitted to the scoring system. A record of each line judge's recorded infringements and those verified at the Chief Judge's workstation will be kept and will be made available to competitors.

2.3. Judging Administration

2.3.1. Collection of Marking Sheets

2.3.1.1. Immediately after a competitor has completed a competition flight and the judges have finished marking, the marking sheets will be collected for perusal at the Chief Judge's workstation. Once any required actions are taken (conference, penalties added, zeroes checked etc.) the marking sheets will be forwarded to the scanner for entry into the scoring system. The individual judges themselves must sign off any changes to their marking sheets.

2.3.1.2. Once the marking sheets have left the Chief Judge's workstation, they come under the supervision and jurisdiction of the International Jury.

2.3.2. Publication of Results

2.3.2.1. The total results for each competitor in each of the competition flights shall be available to the competitors in the agreed working language(s), prior to the start of the next programme but one. The current results of each programme will be published on an information board to indicate the placings of the competitors. The final evaluation and placing will be found and announced after checking by the International Jury, not later than the following day.



2.3.3. Public Announcements

- 2.3.3.1. Prior to the take-off for and during the performance of a programme, details concerning the competitor concerned may be published by any means (radio commentary, etc.).

2.3.4. Protests, Decisions of International Jury, Confidentiality

- 2.3.4.1. All protests will be dealt with by the International Jury, in cooperation with the Chief Judge if his assistance is required and his duties permit. Decisions taken by the International Jury are final and must not be changed later. The judges are advised to keep activities of the Board of Judges and of the International Jury strictly confidential.

2.3.5. Procedure for the Mark of Zero

- 2.3.5.1. A mark of zero can be deserved for one of two reasons: The figure flown may have a single, gross error (e.g. a geometrical error of 90 degrees or more, or simply the wrong figure), or the figure may be basically correct but contain a number of smaller errors that cause the grade to fall to zero by accumulation of downgrading points. The first such zero is called a 'Hard Zero' and is marked on a score sheet with the annotation "HZ". The second type of zero is a 'Soft Zero' and is marked on a score sheet by the annotation "0.0".
- 2.3.5.2. Detailed instruction for the handling of situations where the panel of judges is not unanimous in grades of zero are given in Section 7.2.

2.3.6. Reprimand and Disqualification of Judges

- 2.3.6.1. The reprimands and/or the disqualification of judges by the International Jury shall be administered in compliance with the appropriate Sporting Code.
- 2.3.6.2. In case of a disqualification of a judge, the marking which was the reason for the disqualification will not be counted for the programme in question. CIVA will decide upon the further use of the disqualified judge on the recommendation of the International Jury.
- 2.3.6.3. On the basis of judging data, which have to be available promptly, it is the duty of the International Jury to monitor the performance of the judges.



3. DUTIES OF THE INTERNATIONAL JURY

The activities of the International Jury will be organised systematically by the chairman of the International Jury from the opening of the contest, i.e. from the beginning of training flights. The chairman of the International Jury should allot duties to each of the members of the jury every day. The various duties include:

3.1.1. Meetings

- 3.1.1.1. Attending the meetings of the International Board of Judges (dealing with familiarisation, evaluation, checking the marking sheets).
- 3.1.1.2. If required, holding daily evaluation meetings (after the daily contest programme has been completed).
- 3.1.1.3. Final meeting of the International Jury. Evaluation of the activities of the International Jury and of the development of the contest and a preliminary assessment of the experience gained during the contest

3.1.2. Supervision

- 3.1.2.1. Direct supervision of the International Board of Judges, which is primarily conducted by the Chief Judge. This is to include the calculation of the JPI for all judges.
- 3.1.2.2. Supervision of the line judges and/or supervising and checking the operation of the electronic positioning device.
- 3.1.2.3. Supervision of the activities of the scoring office.
- 3.1.2.4. Supervision of the activities of the Technical Commission.
- 3.1.2.5. Supervision of the activities of the meteorological centre.
- 3.1.2.6. Checking the publication of contest results; making visits to the pilots' camp to gather or give information.
- 3.1.2.7. Supervision of briefings and the drawing of secret lots.
- 3.1.2.8. Checking the availability and accuracy of medals and trophies at the beginning of the competition.

3.1.3. Mediation

- 3.1.3.1. Discussion of protests, if necessary in cooperation with the Chief Judge, the Flight Director, the Chairman of the Technical Commission, and the Contest Director. Taking down on record the proceedings in meetings or activities where decisions are sought (e.g. a note of comments, resolutions, etc.). The International Jury will publish the results of all protests and decisions. The meetings of the International Jury must not impede the progress of the contest.
- 3.1.3.2. Explanatory discussions with chief delegates and team managers to explain measures taken by the Jury; interpretation of the Sporting Code of the FAI and all regulations. This should be done after completion of the daily competition programme or before the beginning of competition flying (i.e. in any case without impeding the progress of the contest).



3.1.3.3. Control of the Unknown Compulsory Programmes in accordance with CIVA Regulations; including supervision, composition, and explanation, as appropriate.

3.1.4. Organiser's Responsibility.

3.1.4.1. The organisers of international aerobatic events must provide the necessary material and technical conditions and the required number of staff in order to enable the International Jury to carry out its functions.



4. REGULATIONS FOR THE ORGANISATION OF GLIDER WORLD AND CONTINENTAL CHAMPIONSHIPS AND INTERNATIONAL AEROBATIC COMPETITIONS

4.1. Administrative Arrangements

4.1.1. Entry Fees

4.1.1.1. World Championships

- a) Every National Aero Club sending a team or a solo pilot to World Championships must pay an entry fee for each participant to the organising Aero Club. Entry fees will be fixed by CIVA on agreement with the organisers.
- b) The organising Aero Club will notify the National Aero Clubs about the date of payment and the receiving agency.
- c) Entry fees will be refunded if the World Glider Aerobatic Championships are cancelled.
- d) Judges, judges assistants, specialists (i.e. for computers), if invited or accepted by the organiser, and three members of the technical commission, selected by CIVA (see 1.4.4), will be free of charges.

4.1.1.2. Continental Championships and International Competitions

- a) Every National Aero Club sending a team or a solo pilot to the event must pay an entry fee for each participant to the organising Aero Club.
- b) Entry fees will be fixed by CIVA on agreement with the organisers.
- c) The organising Aero Club will notify the National Aero Clubs about the date of payment and the receiving agency.
- d) Entry fees will be refunded if the event is cancelled.
- e) The decision on refunding entry fees for other reasons is left to the organisers.
- f) Judges, judges assistants, specialists (i.e. for computers), if invited or accepted by the organiser, and three members of the technical commission, selected by CIVA (see 1.4.4), will be free of charges.

4.1.2. Accommodation, Food and Medical Services

4.1.2.1. At World Championships the organisers will provide adequate accommodation and food for the duration of the event to all members of official teams, solo competitors, officials and other assistants for whom entry fees have been paid, on the understanding that no extra charges will be imposed for those services. In addition, airfield charges and other fees for installations on the airfield will be covered by the entry fees for the persons concerned.

4.1.2.2. The organisers may also choose to exclude the costs for accommodation and food from the entry fees. In any event, they will give assistance with room reservation and will ensure that adequate food supply will be available at or near the airfield.



4.1.2.3. The organisers will be responsible for adequate medical services being available to all official participants.

4.1.3. Towing Aircraft and Crews

4.1.3.1. The organisers must make available towing aircraft and crews who are duly qualified and trained for this purpose.

4.1.3.2. The availability of at least two towing aircraft in service and one standby aircraft must be guaranteed. The performance of towing aircraft must meet the requirements of take-off sequence as shown under 4.2.3.1.

4.1.3.3. Towing fees for competition and training flights may be charged additionally.

4.1.4. Technical Services

4.1.4.1. The organiser will provide technical assistance and hangar space for the competing aircraft, if required.

4.1.5. Interpreters

4.1.5.1. Interpreters for the official language(s) of the contest, working together with the International Jury and the Board of Judges, will be provided by the organisers. The official language(s) must be stated in the Local Regulations.

4.1.6. Briefing

4.1.6.1. Prior to beginning of a contest there will be a briefing by the organisers for Chief Delegates or Team Managers, members of the International Jury and the Judges on flight conditions, the contest programmes and any other problems which might arise over the interpretation of the rules.

4.1.6.2. For familiarisation with and a standardised interpretation of the judging rules, the Chief Judge will hold seminars with the Judges and Team Managers or other Team Representatives and carry out at least one judging test, for which a non-competing pilot shall be available. However, this judging test can also be conducted during the familiarisation flights, in so far as the pilots give their intended flight programmes beforehand to the starter. Throughout the duration of the contest the Chief Judge will hold routine evaluation meetings with the Judges.

4.1.6.3. Prior to beginning of competition flights on each competition day, a briefing will be held for competitors, Officials, Judges, and the International Jury on organisational matters, concerning the competition day, meteorological conditions, etc. The briefing should last not longer than 30 minutes.

4.1.7. Familiarisation Flights

4.1.7.1. Each competitor at World and Continental Championships, timely arrival provided (minimum one day), will be given the opportunity to make at least one flight over the marked performance zone for familiarisation with the local conditions. Organisers should offer a minimum of three days for familiarisation flights and plan to hold judges' briefings and practice judging sessions during this period. Familiarisation flights must be completed prior to the formal opening of the championship.



- 4.1.7.2. Familiarisation flights are subject to the same safety regulations and minimum heights as contest flights, and will be conducted according to the organiser's schedule on a "first come, first served" basis..
- 4.1.7.3. For familiarisation flights, Visual Flight Rules (VFR) of the organising country must be observed, but contest weather minima as specified in section 4.2.2 need not be fulfilled.
- 4.1.7.4. No further training flights are allowed after the start of the championship. In case of violations there will be penalties (see 5.2.4) or disqualifications (see 4.3.3.9). The International Jury may authorise additional familiarisation flights after the opening of the contest for weather or other compelling reasons.
- 4.1.7.5. If it is necessary for purposes of media coverage, competitors may be authorised to fly a demonstration programme which must be approved by the International Jury, the Chief Judge and a two-thirds majority of the Chief Delegates.
- 4.1.7.6. For International Competitions the same procedures apply.

4.1.8. Sequence of Flights (Drawing of Lots)

- 4.1.8.1. The sequence of flights for Programmes 1, 2 and 3 of Championships and International Competitions will be determined by drawings of lots, to be arranged by the Contest Director or his Assistant, in the presence of a representative of the International Jury. Each competitor (or their representative) will draw their own lot. If available, the drawing of lots may be done by a CIVA approved random program under the supervision of the International Jury.
- 4.1.8.2. For Programmes 4, 5, and 6 the competitors will be divided into 3 equal groups. The groups will be based on the provisional overall results after the previous programmes. The order of flight in each group will be determined by lot. The drawing of lots within each group may be made by a CIVA-approved randomising programme, under supervision of the International Jury.
 - a) The order of flight for the groups will be:
Programme 4: I III II
Programme 5: III I II
Programme 6: III II I
 - b) Nevertheless, for the last expected programme in case of time shortage, the order of flight of the groups will be as for Programme 6.
 - c) In case of deterioration of meteorological conditions, the International Jury may authorise the Contest Director to cut the 3rd or 2nd group in order to validate a programme already begun. For a programme to be valid, all the pilots of the 1st group must have flown it. The 2nd group results may also be included if all those pilots have flown.
- 4.1.8.3. The sequence determined by lot may be altered with the approval of the International Jury if special circumstances require (e.g. use of the same glider by different competitors). The first three places must not be altered for the Unknown Compulsory Programmes. After any drawing of lots, the first competing pilot should have an allowance of one hour between drawing of lots and taking off.



4.1.8.4. The first two flights of each contest day and each programme will be by non-competing pilots, if available.

4.2. Operating Regulations

4.2.1. Radiophones

4.2.1.1. The use of technical devices to convey audible information to the pilot is not permitted during International Aerobatic Contests, except for standard air-ground radio sets. Radios will be set to the official safety frequency which is published in the local regulations. The safety frequency is used only to convey urgent competition or flight safety instructions.

4.2.1.2. A competitor receiving any kind of audible information other than instructions from the contest organisation will be liable to disqualification from the contest.

4.2.1.3. Video cameras may be mounted in/on competition aircraft at the discretion of the pilot.

4.2.2. Meteorological Conditions

4.2.2.1. Competition flights will be carried out between sunrise and sunset at the place of competition. If weather conditions deteriorate within this time, the International Jury in consultation with the contest management will decide upon the start and finish of competition flights.

4.2.2.2. The following meteorological conditions are needed:

- a) The performance zone must be free of clouds.
- b) The flight visibility, determined with reference to ground features from the midpoint of the performance zone at the release height for the competition flight just taking place, must be a minimum of 5 km.
- c) The maximum permissible average wind speed in the performance zone should remain inside the limits of the diagram in Section 4.6. If the contest is significantly delayed due to unfavourable weather and there is a serious risk that it may not be completed in time, the limits for wind speed in the performance zone may be increased subject to the following provisions:
 - i) Unanimous decision by the International Jury
 - ii) 100% agreement among the participating teams' Chief Delegates (no abstentions).
- d) The performance zone must be free of precipitation (see also 4.2.2.9.b)).
- e) The performance zone must be free of strong turbulence (see 4.2.2.8); this does not apply to occasional thermals.
- f) Visual Flight Rules for the organising country, including any special competition rules, have to be observed.

4.2.2.3. The International Jury's decides if the weather conditions exist according to paragraph 4.2.2.2. In the case of doubts about adequate meteorological conditions, or if at least two Team Chiefs inform the International Jury that weather requirements are not met, the following procedures apply:



- a) The members of the International Jury should use an aircraft to be made available for this specific purpose and arrange for a weather reconnaissance flight.
- b) If competition flights are in progress, in order to establish the actual weather conditions the next pilot of the towing aircraft will get flight orders by the Jury for a weather report containing all of the required data. The towing aircraft will first cross the performance zone at roughly the release altitude. The competitor will be informed by radio about the purpose of this procedure. The glider pilot will not release during this first towing procedure. If the meteorological conditions are sufficient, the glider will be towed a second time through the performance zone. From this moment regulations according to 4.2.4.2 apply. If the towing aircraft pilot considers meteorological conditions not to be sufficient, and if the Jury decides to cancel the current flight, the competitor will be informed via the "Safety Frequency" or according to the "No-Radio Procedure", and he must release and land without delay, and without performing any aerobatics.

4.2.2.4. The Contest Director provides the competitors, the Chief Judge, the Board of Judges, and the International Jury with hourly information on weather conditions or at shorter intervals if required by meteorological development. This must include average wind speed and wind direction on the ground and in the performance zone at 700m and 1200m height. In case the maximum height is less than 1200m, wind speed and direction must be measured at the upper height limit for the current programme. The weather bulletin with current information on wind speed and direction will be published on a board at the flight line. The bulletin must include the time of the measurement as well as the publication time. The Team Managers are responsible for passing those data on to their teams.

- a) Winds aloft must be measured in or near the performance zone using an approved method with sufficient accuracy e.g. balloon ascent, radar or GPS. The procedure for wind measurement by airborne GPS is described in 4.6.2
- b) When light winds prevail (i.e. less than 5 m/s) it shall be at the discretion of the International Jury not to change the principal axis, even though the wind direction may be more than 45° off the axis, in order to avoid frequent changes during the day.
- c) Under stable weather conditions, adequately meeting the above conditions, hourly information is not required. The International Jury will decide upon the necessity of providing this information.

4.2.2.5. The Flight Director, after consultation with the International Jury, will discontinue competition flights if meteorological conditions deteriorate below the minima of paragraph 4.2.2.2. Such decision may be taken:

- a) If measured upper winds are out of limits.
- b) If the visibility is judged independently by members of the International Jury, the Chief Judge, tow pilots or competitors to be below the minimum.
- c) If there are clouds or precipitation in the performance zone.
- d) If competitors or tow pilots report excessive turbulence.

4.2.2.6. If one of the weather conditions deteriorates to less than the minimum during a run and if the Jury decides on an interruption of the contest flights, the Flight Director must be informed



immediately. If a competitor is being towed, he will be informed via the "Safety Frequency" or according to the "No-Radio-Procedure", whereupon he has to land without delay.

- 4.2.2.7. If the height of release of 1200 m (over datum) is not available due to clouds in the performance zone, but if there are at least 750 m available, the International Jury may cancel the first and/or the last figures of a compulsory programme and have the shortened programme flown or split the programme. The procedure is as follows:
- a) If the cloud base within the performance zone sets to below 1200 m (over datum) and if the Jury decides to cut a compulsory programme or to split a programme, the pilots must be first advised at a briefing.
 - b) If a programme is cut, marks for the omitted figures will be cancelled for the pilots who have flown under normal weather conditions. If a programme is split, the scores of those competitors who have flown the continuous programme will remain unchanged.
 - c) If the cloud base rises to 1200 m (over datum) during a split programme, competitors must fly their full programmes without interruption after the Jury has so instructed and if during the tow normal weather conditions prevail in the performance zone (according to the tow pilot's report).
- 4.2.2.8. The limit for turbulence in the performance zone (see 4.2.2.2) is +2 G (vertical acceleration). The strength of the turbulence will be determined by five consecutive straight penetrations through the performance zone at 200 km/h at different altitudes. The flight must be conducted by a member of the International Jury or a non-competing pilot appointed by the International Jury, as required, at intervals of not less than half an hour. The flight should be made with an aircraft whose wing loading is comparable to that of the lightest competing aircraft. A common G-meter with limit needles is to be used.
- 4.2.2.9. Adverse Weather
- a) If in the opinion of a competitor the weather conditions do not comply with competition rules, they may not start their competition flight and land. If the competition flight is started, a repetition of the flight or parts of the flight due to insufficient meteorological conditions is not possible, except if rain can be proved as the reason for the breaking off of the flight. For the repetition of the flight in such a case, see 4.2.6.8.
 - b) When a pilot encounters rain after release from tow, either before or during the execution of the programme, they may break off their flight and land immediately. The competitor must bring evidence, so they must inform the start line by radio or immediately after landing. In the case where rain cannot be confirmed by a tow pilot or contest officials on the ground (member of the International Jury or a member of the Technical Commission) they must show that the aircraft is wet immediately after landing.
- 4.2.3. Competition Flights**
- 4.2.3.1. The competitors will start in the predetermined sequence. The intervals between releasing will be individually decided by the Board of Judges and will be adapted to the appropriate situation, in order to grant quick continuation. In Compulsory Programmes eight minutes and in Free Programmes ten minutes can be taken as a guide.



- 4.2.3.2. The direction of flight for the start of the Compulsory Programmes shall be determined by the International Jury. The International Jury shall also determine the alignment of the principal axis for the Free Programmes, but competitors may choose to start their first figure along either axis in either direction, provided they show clearly on the drawings of their programmes the direction to be chosen.
- 4.2.3.3. A competitor must begin and end each programme with a distinct rocking of the wing (dipping a wingtip three times with a bank angle of at least 30°) (see 5.2.6). The pilot shall land immediately at the end of a competition flight.
- 4.2.3.4. There will be, if required, a 30-minute break after every two hours of competition flying for the Board of Judges to have a rest.
- 4.2.3.5. The organisers of World and Continental Championships must establish an efficient radio or telephone communication system between the Contest Officials (Contest Director, President of the International Jury, Chief Judge, Flight Director, Chairman of the Technical Commission and all Line Judges) in order to supervise the running of the contest and the contest rules.

4.2.4. Height Limitations

4.2.4.1. The following height limitations have been determined for all contest flights:

- a) Upper limit: 1200 m (over datum)
- b) Upper limit: 750 m (over datum) in a split programme
- c) Lower limit: 200 m (over datum)
- d) In level land the datum will be taken to be the altitude of the airfield. In uneven land the datum will be the highest point found under the performance zone. The altitude will be rounded off to 50 m, for example, a correction of 25 m height difference above the field will be ignored.

4.2.4.2. Cable Release

- a) The cable release height is at the upper height limit. The tow plane must have a barograph. The barographs have to be kept ready for the Jury.
- b) The competitors determine their point where they release. The tow plane will tow in the direction of the principal axis at 1200 m (over datum) with constant velocity through the performance zone. The height and direction will be established one km before entering the performance zone. If the competitor does not release at the end of the performance zone, he will be towed a second time in the same direction. They must release at the end of the second passage at the latest. The tow plane will indicate that requirement by rocking its wings.
- c) For use of the HHMD, see Section 10. Whether or not the HHMD or another CIVA approved height measuring device (see 4.2.4.6.b)) will be used will be decided by the GASC and stated in the Local Regulations.



4.2.4.3. Height Infringements

- a) For an infringement of the lower limit of 200 m (over datum), the competitor will incur a penalty of 70 points for each figure flown entirely or in part below this limit.
- b) For an infringement of the security height of 100 m (over datum) the competitor will be disqualified for the current programme.

4.2.4.4. If the organisers do not have any electronic positioning instrument or height aiming devices available, infringement of the heights of 200 m and 100 m respectively (over datum) shall be determined by the Board of Judges on a simple majority. For better judgement of these heights by the Judges, a neutral aircraft pilot will carry out flights at 100 m and 200 m along the principal axis and the front and back boundaries of the performance zone (if necessary before flying starts each day).

4.2.4.5. When terrain conditions in the vicinity of the performance zone permit, for checking of the lower height limit, aiming devices can be used, similar to the aiming devices for side boundary control. The application of these height aiming devices occurs in the same way from Boundary Judges. Only one device per level is necessary.

4.2.4.6. Electronic height measuring devices (HMDs)

- a) Electronic height measuring devices (HMDs) can be used. The electronic height measuring system used, as well as the rules to operate the system, must be approved by CIVA.
- b) At present there are two systems approved by CIVA: the Huber height measuring device (HHMD), and the Meierhofer height measuring device (MHMD or MGT PM234 Altitude Measurement Device). The MHMD works on the same rules as the HHMD as laid down in Section 10. If additional information is necessary, it will be given in the Local Regulations.

4.2.4.7. Disqualification (for the current programme) for grave infringements of the lower height limit shall be decided by the Board of Judges.

4.2.5. Performance Zone

4.2.5.1. The programme will be flown with reference to the longitudinal and lateral axis marked on the ground. The performance zone (see Section 4.7) will be a clearly and distinctly marked area of 1000 x 1000 m, whose central point will be the intersection of the axis. The performance zone must be situated close to the airfield (runway).

4.2.5.2. Marking of positioning and recording of infringements of the performance zone may be carried out either with an electronic positioning instrument or by Judges in accordance with the judging rules. If the electronic instrument becomes inoperable, the International Jury must decide when Judges are to mark positioning and infringements of the performance zone.

4.2.5.3. At World Championships the organiser will prepare 4 corners of the performance zone with simple aiming devices for the use of the Line Judges in such a case.



- 4.2.5.4. The longitudinal (principal) and the lateral (secondary) axes shall be marked by 7 contrasting marking strips. The size of these markers must be at least 2 x 9 m, with the long side aligned with the direction of the axis. The end of the axis and the 4 corners of the box must be clearly marked. Two arrows will be placed near the central point of the principal axis. They will indicate the specified "into the wind" direction of the principal axis. (see 4.2.3.2 and 4.6).
- 4.2.5.5. The colour of the marking strips must be in distinct contrast to the ground and other airfield markings, which should be removed if possible.
- 4.2.5.6. If the wind vector exceeds the limits in 4.6, the competition will be discontinued. The International Jury will determine any change of the principal axis, as may be necessary and arrange for a rapid shifting of the direction arrows (see 4.2.2.2, 4.2.2.5, and 4.7).

4.2.6. Measures in Case of Mechanical Defects

- 4.2.6.1. In the event of a competing glider becoming unserviceable before the start of a flight, the International Jury may, on the recommendation of the Technical Commission, permit the competitor to use another glider or the same glider following the removal of the defect. In case of the use of a different glider, the participant may conduct test flights, where the reaction of the glider may be tested. The manoeuvres to be flown are to be discussed with the International Jury beforehand. The International Jury will determine the number of test flights, considering the requirements of flight safety.
- 4.2.6.2. In the event of a competitor breaking off his competition flight in case of technical damage which is beyond the pilot's control after take-off, he may be allowed to repeat the flight, provided that evidence of the damage can be furnished to the Technical Commission within 2 hours after landing. For finding the damage only, the following persons will be permitted to work on the glider: the competitor and the mechanic named by the competitor, plus the members of the Technical Commission (except the one belonging to the pilot's Aero Club) and the International Jury. When the cause of the damage has been found, the damage will be repaired by the mechanic of the glider and other experts, as recommended by the Technical Commission. As the situation requires, a test flight may be conducted after a repair.
- 4.2.6.3. Any damage will be counted as such, provided it is a break or deformation found on parts of the glider without any special devices except magnifying glasses
- 4.2.6.4. The following defects will not be counted:
- a) incorrect adjustment,
 - b) technical trouble caused by dirt if attributed to negligence of the competitor or his team,
 - c) insufficient or missing safety devices causing a change of settings during the flight,
 - d) defect caused by pilot exceeding the flight limits of the aircraft,
 - e) In the cases (a) to (d) the competitor will not be permitted to repeat his flight.
- 4.2.6.5. The International Jury must, not later than five hours from the landing of the competitor concerned, decide whether or not a repetition flight will be approved. In the case of doubt on



the basis of the statement by the Technical Commission, the International Jury shall decide in favour of the competitor.

- 4.2.6.6. In order to avoid any delay in the progress of the contest, the flight will be repeated at the end of the current programme even if this is prior to the decision of the International Jury. In the case of an illness or of a technical defect, the latest moment a competitor can fly depends on Regulation 5.1.3.4 and 2.3.2.
- 4.2.6.7. The sequence of repetition flights is determined by the sequence of interruptions of competition flights.
- 4.2.6.8. A competitor making a repetition flight must re-fly the entire programme. Judging and scoring will be continued from the figure during which the technical problem occurred in the interrupted programme.
- 4.2.6.9. In the event that a technical problem arises with an aircraft that prevents the continued participation of a significant fraction of the competitors, the International Jury may, after discussion with the Chief Delegates, declare the contest concluded. The nature of the technical problem must be confirmed by the Technical Commission.

4.2.7. No Radio Procedure

- 4.2.7.1. The tow plane must be in continuous radio contact with the Chief Judge on the "Safety Frequency" or the competition must be terminated.
- 4.2.7.2. If the competitor has no operating radio on board or does not confirm instructions from the Chief Judge or the Contest Organisers, the following signals from the aircraft pilot to the glider pilot are applicable:
 - a) No release in the performance zone during the first towing procedure: Significant rudder motion, at least 0.5 km prior to reaching the performance zone.
 - b) Release followed by landing without delay and without performing aerobatics: Significant wing rocking at least 0.5 km prior to reaching the performance zone.
- 4.2.7.3. Should the glider pilot wish to confirm these instructions, he will use the same motions, whereupon the aircraft pilot will answer with the corresponding signal.

4.2.8. Video Recording

- 4.2.8.1. An official video recording shall be made from the Judges' position of every individual competition flight in a World or Continental Glider Aerobatic Championship. The official recording shall be available to the International Jury to assist their decision on any protests. The recording shall not be available to competitors or Team Officials at a World or Continental Glider Aerobatic Championship, except in the clarification of a protest in conjunction with the International Jury and with their agreement. The official recording shall also be available to the Chief Judge and the Board of Judges to assist their discussion on matters of fact.
- 4.2.8.2. These video-recordings (tapes) will be given to the Chief Judge after each programme and will be kept in his personal possession until the end of the contest and will only be made available to the International Jury.



4.2.8.3. After the completion of the championships, the recording may be released by the organisers for use in training.

4.2.9. In-flight Data Recording

4.2.9.1. To force such projects to be available for glider aerobatic contests in the future and to test such systems, in-flight data recording, electronic positioning instruments, etc. are allowed for use in World and Continental Aerobatic Championships and International Competitions, but only in cooperation with and by the agreement and under control of the International Jury, and without any official status. They can be allocated for official use, if they are approved by CIVA. Such systems, which give special information during the flight to the pilot (audible or visual), are not allowed during competition flights, except if they are approved by CIVA.

4.3. Programmes For World And Continental Championships

4.3.1. Sequence of Programmes

4.3.1.1. The Championship consists of the following six programmes:

- a) Known Programme (Programme 1)
- b) Unknown Compulsory 1 (Programme 2)
- c) Free Programme (Programme 3)
- d) Unknown Compulsory 2 (Programme 4)
- e) Unknown Compulsory 3 (Programme 5)
- f) Free Unknown Programme (Programme 6)

4.3.1.2. The above sequence of programmes is mandatory. Any changes due to weather or other compelling reasons must be authorised by the International Jury.

4.3.2. Known Compulsory (Programme 1)

4.3.2.1. The Known Compulsory Programme will be composed of figures and combinations of figures in normal and inverted flight performed consecutively and continuously, observing the prescribed sequence of figures.

4.3.2.2. Composition

- a) The programme must be such as to enable competitors to fly all figures safely in the glider available to them, provided the glider meets the requirements of full aerobatic certification. It must be guaranteed that the programme can be flown safely within the available height limitations (see 4.2.4).
- b) Performance data and flight characteristics of the expected gliders have to be considered.
- c) The Aresti Catalogue (Condensed), Glider Version will be the reference source for figures to be flown in all competition rounds. For Advanced contests the restrictions of paragraph 4.3.5 apply to all programmes.



- 4.3.2.3. Programme 1 of World and Continental Championships “UG” and “AG” will be selected by CIVA at least six months prior to the next World Championships and be published accordingly.
- 4.3.3. Unknown Compulsory Programmes 1, 2, 3 and Unknown Free Programme (Programmes 2, 4, 5 and 6)**
- 4.3.3.1. Programmes 2, 4, 5 and 6 must contain a minimum of 28 figures or figure combinations, selected by the Chief Delegates or Team Managers (at the discretion of the National Aero Club concerned) from Section 9. For Advanced contests the restrictions of paragraph 4.3.5 apply. Four figures maximum can be chosen in each of the families 2, 5, 6, 9.9, 9.10, and 9.11/12. No figure or combination of figures may be selected with a K higher than 40 (“AG” 35). In composing the programmes they must not be replaced by other figures. The International Jury may select additional figures.
- 4.3.3.2. Figures shall be selected taking into account the flight characteristics and operating limits of the competing gliders and the safety of all pilots. If the representative of a team or an individual competitor is able to show within 30 minutes from the completion of figure selection that a selected figure may exceed the operating limits of competing gliders, the International Jury will ask the team which proposed this figure either to replace or modify it. After this time (30 min.) the figure selection is considered final.
- 4.3.3.3. The list of figures in Section 9 for Programmes 2, 4, 5 and 6 will be approved by CIVA according to the Aresti System (Condensed) for Gliders. The operating limits of gliders available (full aerobatic certification) must be considered in compiling the list. This list should be re-approved at each CIVA meeting prior to a World Championship, if necessary.
- 4.3.3.4. If there are more than 28 teams, 28 representatives will be determined by secret drawing of lots each to select a figure used in composing Programmes 2, 4, 5 and 6. If there are less than 28 teams, their representatives will first select one figure. Then the teams will draw lots a second third and fourth time if necessary in order to determine which teams will choose a second, third and eventually fourth figure until a total of 28 is reached. In the case of teams who select two or more figures, one must be a reversing figure and the sum of coefficients of the two figures must not exceed 60 (“AG” 55). If they choose 3 figures the sum of the coefficients of the figures cannot be more than 80 (“AG” 70). If a team has to choose 4 figures, the sum of the K must not be more than 95 (“AG” 85). All additional figures will be selected by the International Jury.
- 4.3.3.5. The same catalogue number cannot be chosen twice (except for rolls) and except the figures selected by the International Jury.
- 4.3.3.6. The sequence of figures for Programmes 2, 4, and 5 will be composed by the International Jury from the proposed figures and the additions of the International Jury. All the proposed figures should be used to compose programmes 2, 4, 5 and 6. The figures they add shall be solely for the purpose of aiding the composition of the sequence; nevertheless, they may add figures in order to reach the minimum of 175 K (“AG” 130K) if necessary. Figures changing the direction may also be added. For this purpose and to avoid exceeding the maximum coefficient for the programme, the International Jury is entitled to modify one or more of the proposed figures without changing its basic characteristics. In any event the total of figure coefficients must not exceed 190 (“AG” 145), nor be less than 175 (“AG” 130). This may be exceeded by 3 points to facilitate composing the programmes.



- 4.3.3.7. If the representative of a team or a single competitor is able to show within 30 minutes after issue of a programme that the sequence of figures for an Unknown Compulsory Programme designed by the International Jury is a risk to flight safety, then the International Jury must design a revised sequence, without changing the figures selected according to 4.3.3.1. After this time (30 minutes) the Unknown Compulsory Programme is considered as approved by the pilots.
- 4.3.3.8. The Unknown Compulsory Programmes cannot be flown earlier than 12 hours after approval by the pilots (4.3.3.7).
- 4.3.3.9. Training for Unknown Compulsory Programmes is not allowed. Competitors violating this regulation will be disqualified (see also 5.2.4.1).
- 4.3.3.10. The figures for Programme 6 are selected by the International Jury from all the teams' proposed figures with a total K of at least 180K ("AG" 130K) and no more than 190K ("AG" 140K). Each competitor composes their own sequence for Programme 6 from these figures. No more than two linking figures may be added. The K-factor of linking figures will be set at 5K each for two figures or 10K for a single figure. Competitors will be given the list of figures no less than 24 hours before the deadline for submission of the Free Unknown programmes.
- 4.3.3.11. No later than 24 hours before the first flight of Programme 6, the competitors must submit three standard CIVA forms for their Programme 6. The forms must be completed in readable black writing according to paragraphs 4.3.4.5.b) to 4.3.4.5.f). The responsibility for accuracy and conformance of Forms A, B and C lies with the competitor. Any pilot who has not submitted their Programme 6 forms on time will not be allowed to take part in Programme 6.

4.3.4. Free Programme (Programme 3)

4.3.4.1. Coefficients.

- a) The Free Programme is selected by competitors according to the Aresti System, Glider Version. For Advanced contests the restrictions of paragraph 4.3.6 also apply to the Free Programme. Catalogue numbers may be used only once, except for horizontal lines (sub-family 1.1) and slow rolls (family 9.1).
- b) The final sum of figure coefficients must not exceed the amount of 230 ("AG" 160) with a maximum of 10 figures. The sum of the normal figure coefficients may be as large as 233 ("AG" 163), but will be reduced to 230 ("AG" 160), starting with the highest value, by removing one point from the highest coefficient figure that has not had a point removed. In form "AG" the original figure coefficient will be given as well as the reduced value (see also 4.3.6 and 4.3.7).

4.3.4.2. Versatility "UG"

Free Programmes must contain at least one figure each from Family 2 and Families 5 through 9 of the Aresti Catalogue (Condensed), Glider Version, as specified in the following:

- a) From Family 2 (turns and rolling turns) sub-families 2.3 through 2.20, at least a rolling turn with one full roll.
- b) From Family 9 (rolls and spins) at least:
 - i) A half slow roll (sub-family 9.1)
 - ii) Two successive elements of a hesitation roll (sub-families 9.2, 9.4 or 9.8)



- iii) A half positive flick roll (sub-family 9.9)
- iv) A half negative flick roll (sub-family 9.10)

4.3.4.3. Versatility “AG”

Free Programmes must contain at least one figure each from Family 2 and Families 5 through 9 of the Aresti Catalogue (Condensed), Glider Version, as specified in the following:

- a) From Family 2 (turns and rolling turns) sub-families 2.1 or 2.2, at least one figure. Alternatively Catalogue No. 2.3.1 may be flown.
- b) From Family 9 (rolls and spins) at least:
 - i) A half slow roll (sub-family 9.1)
 - ii) Two successive elements of a hesitation roll (sub-families 9.2, 9.4 or 9.8)

4.3.4.4. The beginning of the Free Programme can be in normal or inverted horizontal flight, but must be finished in normal horizontal flight.

4.3.4.5. Sequence Submission

- a) Not later than at the opening briefing of the contest, each competitor must submit a computer file for the programme, in an acceptable format, to the Contest Director for verification of compliance with the relevant rules. The file must contain completed pages for the three Forms described below. The currently acceptable file format is Microsoft Visio using Aresti software. If any pilot has not submitted their Free Programme by the opening briefing, they will not be allowed to take part in Programme 3.
- b) Form “AG” will show all symbols, catalogue numbers and coefficients.
- c) Form "B" will show the continuous sequence of the programme as it would be flown with the wind blowing from right to left, plus a table listing the Figure Numbers, their Catalogue Numbers and coefficients.
- d) Form "C" will show the continuous sequence of the programme as it would be flown with the wind blowing from left to right.
- e) Form "B" and "C" must show clear symbols for the wind direction.
- f) Only normal Aresti symbols, catalogue numbers and coefficients shall be entered. Any other writings or notation will be disregarded.

4.3.4.6. Checking

- a) It shall be the duty of the organiser's officials to check Form A of each competitor against the symbols on Form B and C, taking the catalogue numbers of the Aresti catalogue (latest edition) as definitive. Any inaccuracies in the drawing of symbols or in the quoting of coefficients or the discovery of any cases of repetition of catalogue numbers will be referred to the competitor's Team Manager so that the Forms may be corrected and resubmitted. The final responsibility for accuracy and conformance of Forms A, B and C lies with the competitor. A written record of the Free Programme



check showing date, time and name of checker shall be filed with the original Free Programme forms submitted by the competitor.

Note that the direction of rotation of rolls is not prescribed by GAF rules, i.e. direction of rotation of rolls is at the pilot's discretion. The same applies for direction of turns and rolling turns, as well as direction of rotation of stall turns and normal or inverted spins.

- b) In order to avoid possible alteration and resubmission of Forms during the contest, National Aero Clubs may submit the competitor's forms to the organisers for checking not earlier than one month prior to the beginning of the contest.

4.3.4.7. Publication and Changes

- a) After completion of the examination of the Free Programmes by the Contest Officials, all Free Programmes will be made available to all participants in an appropriate manner. Protests can be made up to 6 hours after these Free Programmes become available.
- b) After the beginning of publication of the Free Programmes, changes are only possible in case of an error in a programme. After the end of the protest time no changes are allowed. In case of errors which are found after this moment which are not acceptable (for example too high a sum of coefficients) the programme can be changed by the Chief Judge with the agreement of the International Jury.

4.3.4.8. The organisers will be responsible for reproducing a sufficient number of copies of competitors' programmes to meet the contest requirements. One copy of Form B or C for all Free Programmes are to be provided to each Team prior to the start of Programme 3.

4.3.5. Allowed Figures "AG"

Except for the following restrictions, all the figures from the Aresti Catalogue (Condensed), Glider Version, may be flown.

- a) No full negative loops. No high-speed negative part-loops of more than 45° (1/8th loops).
- b) No rolling turns, except Catalogue No. 2.3.1 in Free Programmes.
- c) No rolls vertically up. No more than ¼ roll vertically down. No flick rolls, positive or negative. No inverted spins.

4.3.6. Coefficients for the Programmes "UG"

Programmes	1	2, 4, and 5	3	6
Total coefficient of figures	max 190K	max 190K min 175K	max 230 (233)K	max 200K min 180K
Positioning	35/15K	35/15K	50/15K	35/15K
Harmony	10K	10K	20K	20K

4.3.7. Coefficients for the Programmes "AG"

Programmes	1	2, 4, and 5	3	6
Total coefficient of figures	max 145K	max 145K min 130K	Max 160 (163)K	max 140K min 130K
Positioning	35/15K	35/15K	50/15K	35/15K
Harmony	10K	10K	20K	20K



4.4. International Competitions

4.4.1. Programmes

4.4.1.1. The same procedure applies as for World Championships.

4.4.2. Winners and Placings

4.4.2.1. Winners, second and third placings in the overall class and team competition will be established.

4.4.2.2. Winners, second and third placings will be honoured by the organisers in an appropriate way.

4.5. Awards

4.5.1. World and Continental Championships “UG” and “AG”

4.5.1.1. The World or Continental Champions, second and third placings in the various programmes will be awarded Gold, Silver and Bronze medals and Diplomas of CIVA.

4.5.1.2. The Overall World or Continental Champion will be awarded the Gold Medal and Diploma of the FAI.; the second and third placings will be awarded a Silver and Bronze Medal respectively and Diplomas of the FAI. The fourth through sixth placings will be awarded Diplomas of the FAI.

4.5.1.3. The World or Continental Team Champions, comprising the three highest-scoring pilots and the Team Manager, will each be awarded the Gold Medal and Diploma by the FAI. The second and third placings will be awarded FAI Silver and Bronze Medals respectively and Diplomas of the FAI. The fourth through sixth placings will be awarded Diplomas of the FAI.

4.5.1.4. The organisers are recommended to award Diplomas to the placings after the sixth place in the overall ranking and from fourth to sixth place in the various programmes.

4.5.1.5. The organisers are recommended to give awards at World and Continental Championships to the Chief Judge, the Panel of Judges, the Chief of the Scoring Office and all specialists in the computing room.

4.5.2. International Competitions

4.5.2.1. Granting awards in the form of medals and certificates will be left to the organisers.

4.6. Wind Limits and Measurement

4.6.1.1. The diagram below shows the wind speed and direction limits.

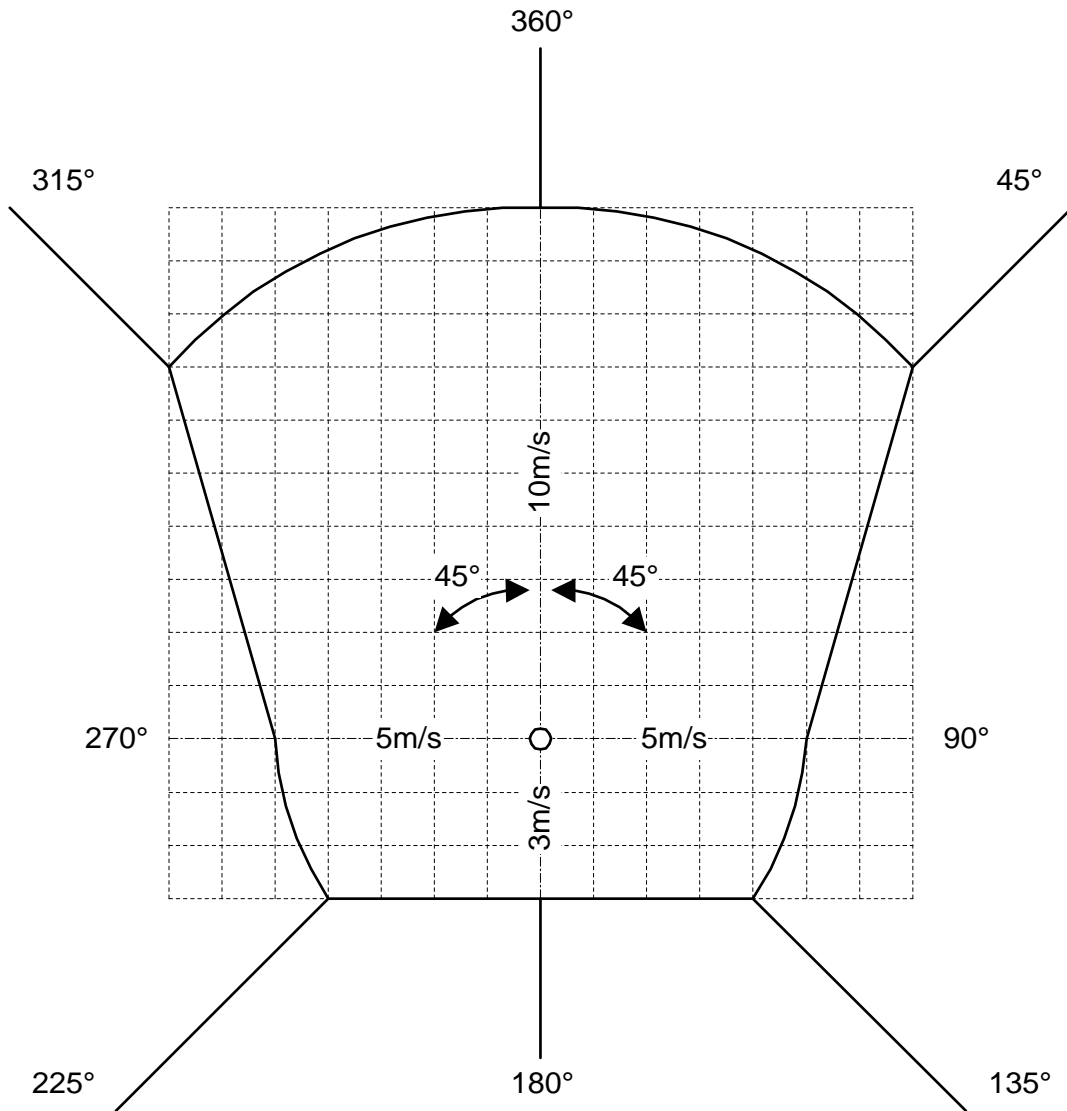



4.6.2. Procedure for Measurement of Wind Speed and Direction by Airborne GPS

- 4.6.2.1. Wind velocity shall be measured at 700m and 1200m (over datum) using the procedure described below. If the wind cannot be measured at 1200m due to clouds, measurement shall be made at the greatest height possible rounded to a multiple of 100m.
- 4.6.2.2. Any GPS device either permanently fixed or hand held may be used, provided it is designed for speeds up to at least 150 km/h.
- 4.6.2.3. Flight Procedure:
- Choose an airspeed appropriate for the aircraft and the weather conditions. The pilot must be able to maintain a horizontal flight path at this speed.
 - Fly heading true north and maintain the chosen speed as accurately as possible. Read groundspeed indicated on the the GPS device (V_n). Repeat this procedure for headings south, west and east. Record the ground speeds V_s , V_w and V_e for those directions. The fastest track to get these data is to fly a rectangle.
 - Repeat this procedure for both required heights.
- 4.6.2.4. Calculation of wind speed and direction: (V = ground speed measured by GPS, W = wind speed)

- Determination of the north-south wind component: $W_{ns} = \frac{|V_n - V_s|}{2}$. If $W_{ns} = 0$ then the wind direction is 090° or 270° .
- Determination of the east-west wind component: $W_{ew} = \frac{|V_e - V_w|}{2}$. If $W_{ew} = 0$ then the wind direction is 360° or 180° .
- Total wind speed: $W = \sqrt{W_{ns}^2 + W_{ew}^2}$
- Wind Direction: If the wind direction is not one of the cardinal points (from 4a or 4b) the table below should be used.

N/S component	E/W Component	Wind Direction WD
$V_s > V_n$	$V_e > V_w$	$WD = 270^\circ + \arctan\left[\frac{V_{ns}}{V_{ew}}\right]$
$V_s > V_n$	$V_e < V_w$	$WD = \arctan\left[\frac{V_{ew}}{V_{ns}}\right]$
$V_s < V_n$	$V_e > V_w$	$WD = 180^\circ + \arctan\left[\frac{V_{ew}}{V_{ns}}\right]$
$V_s < V_n$	$V_e < V_w$	$WD = 90^\circ + \arctan\left[\frac{V_{ns}}{V_{ew}}\right]$



4.7. The Aerobatic Performance Zone

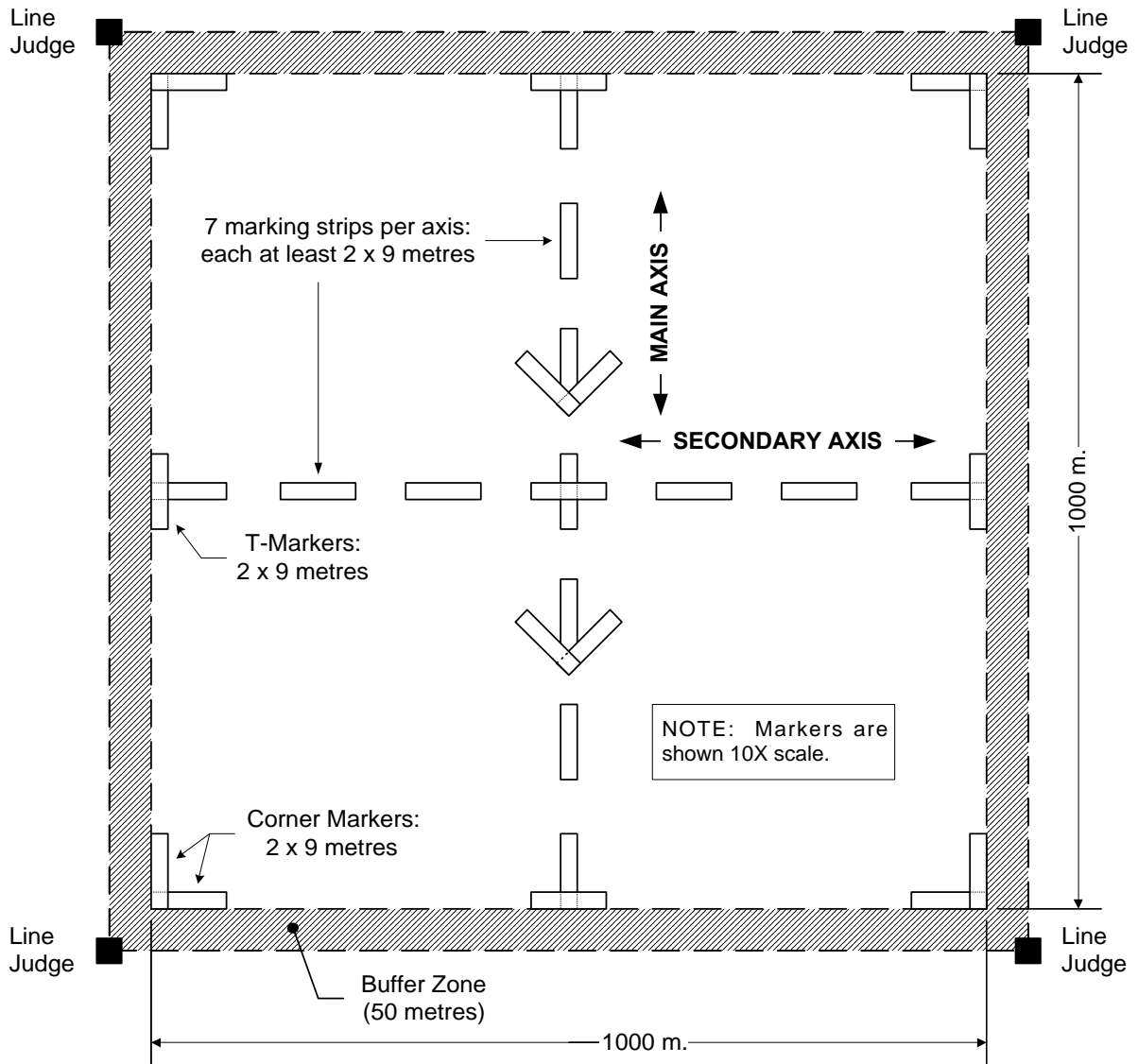



5. REGULATIONS FOR THE EVALUATION OF COMPETITION FLIGHTS IN INTERNATIONAL AEROBATIC EVENTS

5.1. Evaluation of the Performance

5.1.1. Judges

- 5.1.1.1. Each programme of World and Continental Championships will be marked by the Judges using a standardised system (see 5.3 and Section 6). The same rules should apply to International Competitions.
- 5.1.1.2. The marks given by a Judge to a pilot of his/her own country shall be included.
- 5.1.1.3. Where the majority decision of the Panel of Judges is required, in a case of disagreement about the penalisation of the flight of a competitor, the Chief Judge shall have a casting vote in the event of a tie.

5.1.2. Marks for Figures

- 5.1.2.1. The Judges will independently mark the quality of each figure and its components using numbers 0 to 10, accurate to 0.5, using the point reduction system for each element of a figure as described under paragraph 5.3.1 and Section 6. A Hard Zero (HZ) mark will be awarded if the figure is incorrect or missing, in accordance with paragraph 5.3.3.1. The scores will be calculated by multiplying the coefficient (K) for each figure by the mark given to each.
- 5.1.2.2. When marking the quality of the performance of individual figures, the Judges have to consider the following general principles:
 - a) the geometry of the figures (including shape, radii, angles, plane of flight, direction of flight), which must be in compliance with the prescribed criteria;
 - b) the precision of the performance, for which there are Marking Criteria set out in Section 6;
 - c) the distinctly recognizable start and finish of each figure with a horizontal line;
 - d) that in judging a figure which comprises a combination of manoeuvres, the marking criteria of its various components continue to apply, but the combined manoeuvres are to be taken as a unit;
 - e) that the length of lines and the size of radii caused by the flying characteristics of an aircraft are not to be taken into account in the marking;
 - f) that inverted figures are judged by the same criteria as upright figures.
- 5.1.2.3. If a judge misses seeing a figure, or any part of a figure such that a grade cannot be given with full confidence, the Judge will give a mark of "Average" or "AG" to that figure.

5.1.3. Calculation of Scores

The calculation of scores for a competitor's programme will be as follows:



- 5.1.3.1. The marks given by a Judge are processed according to Section 8, with the final scores being determined for a programme as a whole. A CIVA-approved software programme must be used.
- 5.1.3.2. It shall be a duty of the Organiser to arrange for the publication of the competition results in accordance with Rule 5.1.3.1. The marking sheets must be made available to the competitors, Chief Delegates, Team Managers, and Contest Officials for information and/or checking before the start of the subsequent programme.
- 5.1.3.3. A copy of the files generated by the CIVA-approved Computer Scoring System must be available to any official or Team Manager upon request. The media used for that copy will be supplied by the requester and has to be compatible with the computer being used by the Contest Organisers. This could include serial or parallel data transfer techniques if diskettes are not available. A fee of \$25.00 will be charged for the copy of all data, except for the data supplied to the International Jury. A complete copy of all the files must be sent to the President of CIVA after the contest is finished and the media used shall be supplied by the Contest Organiser. No fees will apply in that case.
- 5.1.3.4. The raw scores of each pilot, by judge, will be published after that pilot's flight without classification or normalisation of the scores. Penalty points will also be listed. The final scores and classification of the performance of the pilots is to be made after the completion of each programme. These will be available not later than the beginning of the flight programme subsequent to the next.

Example: Programme 1 final scores must be available before the beginning of Programme 3.

5.1.4. Marking of Positioning

- 5.1.4.1. If an electronic tracking instrument is operated, the observance of the performance zone and the positions of the individual figures are recorded by Positioning Judges (see 2.1.5.4).
- 5.1.4.2. Conventional Marking
- a) If the conventional marking of positioning is used the Board of Judges will give the position marking according to the total impression of the balanced use of the performance zone. In addition, they watch the infringement of the 200 m and 100 m (over datum) height levels. The Line Judges only record infringements of the three sides of the performance zone.
 - b) If aiming devices for horizontal lines are used, the checking of the lower limits of the performance zone is subject to Line Judges.
- 5.1.4.3. If the conventional method is used the infringements of the performance zone boundaries (and eventually also the 100 m and 200 m levels) will be observed by two Line Judges assisted by aiming devices, located along the side adjacent to the Panel of Judges on upwind and downwind corners.
- 5.1.4.4. Placement and Coefficients
- a) Competitors should try to perform their programmes within the available air space in axial symmetry. It is not required, however, to use up all the available airspace vertically, if the number and altitude requirements of the figures in a particular programme would normally allow completion at an altitude higher than the minimum.



The highest marks will be given if the central point of a competition flight is above the intersection of the x/y axes.

- b) As the use of an electronic tracking instrument will provide a higher degree of objectivity, two different scales of the coefficients for the marking of positioning are required:

	Electronic Instrument	Conventional Method
Compulsory Programmes	K = 35	K = 15
Free Programmes	K = 50	K = 15

5.1.5. Harmony

5.1.5.1. A flight is harmonious when the individual figures are clearly separated from one another, follow one another at similar intervals in time and space, and when the exit velocity of one figure agrees with the entrance velocity of the next figure.

- a) No subtraction of the harmony mark is given when a long pause in a compulsory programme is unavoidable due to un-harmonic construction.
- b) When long gliding pauses are unavoidable because of strong winds, no corresponding reductions will be given to the harmony mark.

5.1.5.2. The harmony of a programme is disturbed if:

- a) a long interruption between two figures is found, which is not based 5.1.5.1 a) or b),
- b) direction changes between figures are made,
- c) after a mistaken or abandoned figure a direction change of more than 90° is made, unless the correction can be done in a vertical line (e.g. after a failed stall turn / hammerhead),
- d) the line between two figures (horizontal, descending, or ascending) is changed in its inclination in order to increase or reduce speed.

5.2. The Penalty Point and Devaluation System

5.2.1. Infractions of Height Limits

5.2.1.1. A competitor flying a figure or part of a figure lower than 200 m (over datum) will receive 70 penalty points for this figure. A competitor flying his programme lower than 100 m (over datum) will be disqualified for this flight (see 4.2.4.3).

5.2.1.2. In the case where the flight is monitored by an electronic means (HMD), the Judges will mark all the figures regardless of the altitude and also note down any height infractions they observe. The excursions below 200m will be recorded at the Chief Judge's position and penalty points will be assessed accordingly. 70 penalty points will be given for any figure before or during which the 200m signal is received.

5.2.1.3. In the case where the lower height boundary is supervised by using an aiming device, the respective Line Judge will transmit a height infraction to the Chief Judge. If there is a



figure flown below the height limit of 200m at any one position, this figure will be given a penalty of 70 points.

- 5.2.1.4. The end of a figure occurs as soon as the aircraft completes the curved portion of the manoeuvre and enters horizontal or gliding flight, or as soon as the aircraft flies through the horizontal line between two figures. In rolls, the end of the rotation along the longitudinal axis is taken to be the end of the figure.
- 5.2.1.5. In the case where the Judges assess the lower boundary, each Judge will note in writing a height infringement on his score sheet, independent of the other Judges; however, he continues to evaluate the figure being flown.
- 5.2.1.6. Infringements of the lower and upper height limits will be estimated by the Judges and will be penalised only if a simple majority has recognised the violation and duly recorded this on their marking sheets. In case the required simple majority could not rise from a vote within the Board of Judges, the Chief Judge shall have a casting vote. If an HMD is in operation, the official video should be checked to verify audible outputs from the HMD receiver. An infringement of the lower 100 m level must be agreed by at least a two-thirds majority of the Judges. Which figures will be given penalties will be determined by the Chief Judge at the end of a flight .

5.2.2. Infringements of the Performance Zone

5.2.2.1. Excursions

- a) Every excursion outside of three boundaries of the performance zone (plus 50m tolerance) will be separately registered. The time of excursion will be determined by the two Line Judges located along the Panel of Judges on upwind and downwind corners. Such excursions will be penalised by 2 penalty points per second.
- b) The time of excursion outside the rear boundary will not be registered and penalized but the Judge may deduct 0.5 to 1.0 from the mark for each figure badly visible due to unreasonably long distance from the Judges' position (see 6.9.2 "Optimal Placement of Figures").
- c) In the event of a competitor flying around the outside of a corner, then the total time recorded by the line judge at that corner shall be taken as the correct time for this excursion. If the two Line Judges measure the duration of an excursion outside their common boundary differently, an average of the two times will be calculated and the penalty points awarded accordingly.

5.2.2.2. All figures of a programme even when they are flown outside of the side boundaries of the performance zone, are given marks; however wide excursions may influence the position mark.

5.2.2.3. Figures flown far outside of the performance zone may graded Soft Zero (0.0) because of poor visibility.

5.2.3. Programme Interruptions

5.2.3.1. Each programme interruption will be given 70 penalty points. A programme interruption is a direction change of more than 90° that is not designated in the flight programme (exception: manoeuvres covered by 5.2.3.2). These can be:



- a) an interruption of a programme in order to return to the performance zone,
- b) an intentional programme interruption with arbitrary direction changes (e.g. full circles).

5.2.3.2. If a pilot is compelled to change his direction after a mistake or after an abandoned figure in order to resume the predetermined direction and has already received a Hard Zero mark for that figure, no penalty points for an interruption will be subtracted. This correction of direction or orientation should not be more than a heading change of 180 degrees or attitude change of more than one half roll or loop.

5.2.3.3. The pilot should not rock the aircraft's wing before or after a programme interruption. Wing rocking indicates the final conclusion of the programme.

5.2.3.4. A programme interruption in order to gain altitude by thermalling will lead to disqualification for that flight programme.

5.2.4. Violation of Training

5.2.4.1. Training for the Unknown Compulsory Programme will lead to disqualification from the entire contest.

5.2.4.2. The pilot will be assigned 200 penalty points for each occurrence of a training manoeuvre which is not part of the current programme.

5.2.5. Failure to Appear

- a) In the case of the failure of the participant to appear at the designated take-off time, the pilot can be changed to the end of the current programme in the Known Compulsory and the Free Programmes, however he will receive a warning and 300 penalty points for that flight. If the same pilot fails to appear again, he/she will not be allowed to start in that programme.
- b) In the case of the failure to appear at the designated take-off time for the Unknown Compulsory Programme, the participant will not be allowed to participate in that flight programme. Deviations from this rule can be made on a case by case basis only by the International Jury.
- c) In urgent cases the participant may report late to the starter, but the variation from the stated rules can only be determined by the International Jury.

5.2.6. No Wing Dip at the Beginning or End of a Programme

5.2.6.1. The pilot will be given 35 penalty points for failure to do a wing dip at either the beginning or ending of a programme (or doing it so little that it is not apparent to the grading judges).

5.2.6.2. The Line Judges stop considering boundary infringements at the first wing dip marking the end of the flight programme or, in case that it is not seen, 10 seconds after the aircraft leaves the performance zone after the end of the last figure.

5.2.7. Violation of Flight Regulations and Dangerous Flying

5.2.7.1. Competitors found guilty of violating flight regulations and/or causing a dangerous situation will, on the recommendation of the International Jury, be disqualified by the Contest Director.



5.3. Rules for the Marking of Figures

5.3.1. Deductions

5.3.1.1. A reduction of the mark by one will be given for each 5 degrees of directional deviation from the pre-stated direction at the completion of a figure. For directional deviations of 2.5°, the mark will be reduced by 0.5. The competitor should, prior to the beginning of the following figure, regain the correct heading. If the competitor continues in the wrong direction, rather than correcting his heading, the mark for each of the subsequent figures of the programme will be reduced by one per 5 degrees directional inaccuracy, until the correct direction is re-established.

Example: The competitor has completed a loop at a deviation of 15 degrees to the left from the pre-stated flight direction without correcting the mistake. The pilot continues the following figures in the same direction. The marks will then be reduced by three for each figure, i.e. the competitor cannot be given more than a mark of "7" per figure.

5.3.1.2. For deviations in the vertical (90°) or ascending/descending 45° lines, the mark will be reduced by one per 5° directional deviation.

5.3.1.3. Horizontal lines will be judged on flight path, not the attitude of the glider (see 6.3.1.1 and 6.7.1.1). Horizontal lines in glider aerobatics may be inclined between zero (0) and ten (10) degrees below the horizon.

5.3.1.4. The reference for vertical and 45 degree lines is the angle of the zero-lift axis (see 6.3.2.1) relative to the true horizon. On vertical and 45 degree lines, the flight path is subject to wind influence and must be ignored when judging these lines.

5.3.1.5. If while in the pre-stated flight plane (vertical, horizontal, 45° inclination) a competitor allows his glider to bank around the longitudinal axis, the mark will be reduced by one for every 5° of difference between the actual and the prescribed plane of flight.

5.3.1.6. All figures begin and end on horizontal lines. If there is no recognizable horizontal line between two consecutive figures, the marks for both figures must be reduced by one (1) point each.

5.3.1.7. Over-rotating a roll and rolling the wings back again must be penalised by 1 point per 5° of over-rotation, even if the correct geometry is resumed afterwards, and no matter how quickly the correction is made. The same provisions apply when, at the end of a loop or part-loop, the aircraft is pitched beyond the desired line and then brought back again.

5.3.1.8. Rolls flown in combination with a turn (family 2.3 to 2.20) or loop (family 7.5 and 7.6) must be smoothly continuous; i.e. there must not be any change in the rate of roll from beginning to end.

5.3.2. Soft Zero

5.3.2.1. A valid mark of 0.0 (a "Soft Zero") will be given to a figure if the deductions reflecting the imperfection of the execution of the figure lead to a value lower than 0.5.

5.3.2.2. Additionally, a mark of soft zero will be given if the Judge considers that the figure is incorrectly flown in respect of a criterion that is a matter of subjective perception, rather than clearly demonstrable fact. For example, if the Judge considers that a flick roll or spin never



started proper auto-rotation, or that a tail slide did not move backwards by the required amount..

5.3.3. Hard Zero

5.3.3.1. A grade of “Hard Zero” (HZ) should be given if the judge considers that the figure is incorrectly flown in respect of a geometrical error, as listed below, that is clearly verifiable as a matter of fact. A grade of “HZ” will be given to a figure if:

- a) Any figure is flown which does not conform to the drawing held by the judges for marking purposes (Form B or C),
- b) The remaining segment of the turn or loop reaches 90°,
- c) Any deviation from the prescribed direction reaches 90°,
- d) Any other single deviation in geometry/flight path/attitude/rotation reaches 90°.
- e) The pre-stated figure or any part of it is omitted.
- f) Any figure is started behind the judges.
- g) In performing a super slow roll, a half roll is shorter than 4.5 seconds, a complete roll is shorter than 9 seconds, or a one-and-a-half- roll is shorter than 13.5 seconds..
- h) Any part of the figure was not visible as it was flown in or behind cloud. If the figure was visible to a majority of judges, then a grade of “AG” may be given by the unsighted judges.

However, if figures subsequent to a Hard Zero grade are correct and are flown in the correct direction, they shall be marked in the normal way.

5.3.3.2. During a repetition flight (paragraph 4.2.6.8) the figures before the break must all be flown correctly. If a competitor omits or flies such a figure incorrectly, so as to gain an unfair advantage, the grade awarded for that figure during the first flight will be reduced to a Hard Zero

5.3.3.3. When difficulties occur in interpreting the correct application of the "HZ" mark, the Chief Judge may call for a discussion on the spot by the International Judges. The official video may be used in these discussions to help determine matters of fact, but not of perception. Such discussions shall not interfere with the subsequent flights. Form A shall be retained until the final decision is made at the next possible break.

5.3.4. Mix of Zeros

5.3.4.1. The Fair Play System computer software programme will handle a mix of Hard Zeros, Soft Zeros or “AG” grades in accordance with paragraph 5.3.4.4. In order for this to function correctly, the Chief Judge, if necessary after a conference as described in paragraph 5.3.3.3, must fill the Confirmed Hard Zero (CHZ) field on the judging sheets if a Hard Zero was in fact flown. If review shows the figure to have been correct, the “CHZ” box must be left open.

5.3.4.2. If during this process the Chief Judge establishes that there is a mix of Hard and Soft Zeros for the same error, i.e. it is only the extent of the error above 45 degrees that cannot be



established, and these combined Zeros are in the majority for this error, the Chief Judge shall instruct those judges with the Soft Zeros to change their score sheets to Hard Zeros and sign the sheets accordingly. The Chief Judge will then fill the CHZ field. Consequently, no judge will in this instance have a point added to his Hard Zero Anomaly count.

- 5.3.4.3. Where there is a mixture of Hard and Soft Zeros for a figure started behind the Judges (rule 5.3.3.1.f) the Chief Judge shall determine by a simple majority (with the Chief Judge casting a vote as required) if a Hard Zero is applicable. Those judges in a minority, having given a score, shall then bring this score to Hard Zero and sign their sheets accordingly. Judges shall be instructed to grade figures regardless of whether they believe the figure was started behind them. These scores will then be used if the figure is deemed to have been flown in front of the Judges, when the Chief Judge calls for a vote on this issue.
- 5.3.4.4. When a mix of hard and soft zeroes, non-zero marks and/or “AG” grades exists, the following resolution will take place in the computer scoring programme:
- a) “AG” grades will first be set to “Missing”.
 - b) If the “CHZ” box has been filled, then all other grades will be changed to “HZ”.
 - c) If the “CHZ” box is open then “HZ” grades will be set to “Missing”.
 - d) After normalisation, the “Missing” grades will be replaced with Fitted Values determined by the computer.



6. CRITERIA FOR JUDGING GLIDER AEROBATIC FIGURES

6.1. Preface

- 6.1.1.1. The following is an expansion and clarification of the general principles for marking glider aerobatic figures stated in paragraph 5.1.2.
- 6.1.1.2. Basic judging principles are the same in power and glider aerobatics; nevertheless, there are also some fundamental differences. Remember, a Fox or Swift is not a Sukhoi or Extra minus an engine! Aerobatic gliders are still sailplanes, albeit optimized for aerobatics rather than distance soaring. Compared to an aerobatic airplane, a glider has lower limiting load factors with an airfoil which is a compromise between good aerobatic performance and high lift/drag ratio. The relatively long wingspan and high aspect ratio found on gliders produce only moderate roll rates both in slow rolls and flicks.
- 6.1.1.3. The final mark awarded to a figure has many components, but first and most important in any mark is the geometry of the figure as compared to the true horizon and Aerobatic Box axes. Geometry is derived from two distinctly different entities: flight path and attitude.
- 6.1.1.4. Next to figure geometry, harmony is the second most important factor of glider aerobatic performance. It is one of the most difficult – and least understood – tasks of glider judges to mark the harmony of a glider program correctly. The main factors determining the harmony of a glider programme are efficient energy management and even figure spacing.

6.2. Definitions

The following expressions are used consistently throughout the text in a very precise sense according to these definitions:

6.2.1. Angle of Attack

- 6.2.1.1. The angle at which the wings of an aircraft meet the relative airflow.

6.2.2. Angle of incidence

- 6.2.2.1. The angle at which the wing is attached to the aircraft.

6.2.3. Figure

- 6.2.3.1. Each individual component of a sequence, which may comprise one or more manoeuvres in combination; it starts and ends with a horizontal line.

6.2.4. Manoeuvre

- 6.2.4.1. Any one of the basic aerobatic movements, which may be combined to make a figure (e.g., an avalanche is one figure consisting of two manoeuvres – loop and flick roll).

6.2.5. Mark/Point/Score

- 6.2.5.1. **Marks** are assigned (from 0 to 10) by judges, and may be devalued by various **point** values. The **score** is calculated by multiplying the judges' marks by the coefficients (K factors) and adding the products.

6.2.6. Plane of Flight

6.2.6.1. There are three planes of flight in aerobatic competition relative to the true horizon: horizontal, vertical and 45 degrees.

6.3. Flight Path And Attitude

6.3.1. Flight Path

6.3.1.1. Think of the aircraft condensed into a single dot and watch the path this dot takes through the sky. This is the flight path, or track, of the aircraft's centre of gravity. Judging the flight path consists of comparing the observed path with fixed references such as the horizon or the X and Y axes of the Aerobatic Box. (Figure 1)

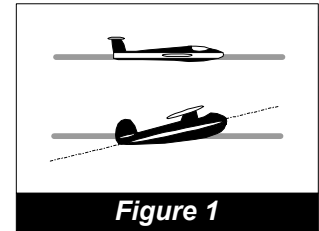

Figure 1

6.3.2. Vertical Attitude

6.3.2.1. Judging vertical lines is based on the attitude of the aircraft and not its flight path. When an aircraft's flight path, in a zero wind condition, is exactly 90 degrees to the horizon, the wings are being held at the correct angle to produce no lift. The aircraft's attitude while in this condition (zero lift) defines the proper judging criterion for vertical attitude. This is called the zero-lift axis.

a) When this zero-lift axis is vertical, the longitudinal axis of some aircraft may not appear to be vertical. (Figure2) This is especially true for most gliders; where, because the wing is attached at an angle of incidence of several degrees, and the airfoil is not symmetrical, a negative angle of attack is required to produce zero lift. The Judge must determine the proper vertical attitude for each aircraft type according to its zero-lift axis. The best opportunity to make this determination is to observe practice flights and note the different vertical attitudes, both up and down, of various glider types.

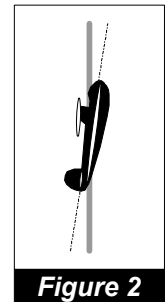

Figure 2

b) An aid for judging the perfect vertical (zero-lift) attitude is to observe vertical rolls. During a truly vertical roll, the aircraft's wings will constantly be parallel to the horizon, something which is especially noticeable after 90 degrees of roll.

c) Be aware that aircraft types whose zero-lift axis does not pass through the tail will make a spiral with the tail during a perfect vertical roll. From the Judges' perspective, this spiral will look as if the tail is shifting off-axis from the zero-lift axis flight path.

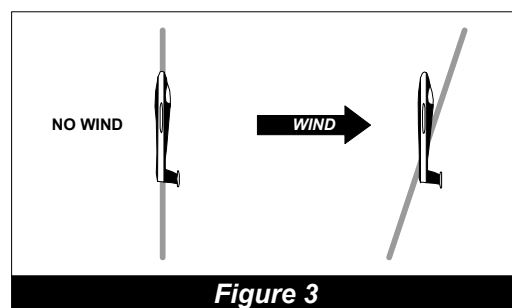
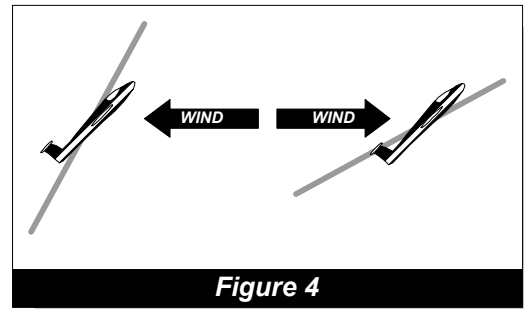

Figure 3

d) When there is a wind of any kind, the observed flight path will be offset from perpendicular to the horizon by some degree. This wind effect must be completely ignored by the Judge, who must only evaluate the accuracy of the vertical attitude. (Figure 3)

6.3.3. The 45 Degree Attitude

6.3.3.1. This is the vertical attitude plus or minus 45 degrees. In view of the difficulty in judging 45 degree lines accurately, scoring deductions should be applied with care. When flown into the wind, a perfect 45 degree line will appear to be steep while the opposite is true when flown downwind. (Figure 4) As with the vertical attitude, this wind effect must be completely ignored by the Judge who must only evaluate the accuracy of the 45 degree attitude.



6.3.3.2. Gliders gain airspeed on 45 degree down lines and lose airspeed on 45 degree up lines. When the pilot keeps the zero-lift axis at the prescribed 45 degree angle to the horizon, the flight path becomes flatter on the up line as lift decreases with airspeed as well as on the down line when lift is increased with increasing airspeed. These changes in the flight path angle must also be ignored when judging 45 degree lines. The prescribed deduction is one (1) point per five (5) degrees of deviation from the correct geometry (0.5 points per 2.5 degrees).

6.4. Marking

6.4.1.1. It should be assumed that a competitor is going to fly a perfect figure, so a Judge starts with a mark of 10. As the figure is performed, the Judge then begins to find faults (if any) with what he or she sees, and starts downgrading as the figure progresses. This system of marking is required by the rules as opposed to waiting until the figure is finished and assigning a mark based on overall impression. The latter causes the judging to be erratic and inconsistent.

6.4.1.2. Should a competitor fly a figure so far away from the judges that the exact detail is not apparent to downgrade, then the maximum grade should be 5.0. Considerations for Hard and Soft Zeros shall not change in these circumstances. Should the judge consider that the detail of the figure could not be determined at all, a Soft Zero should be applied to the figure.

6.5. Summary

6.5.1.1. Remember, it is the Judge's job to find fault: be a nit-picker. On the other hand, give a mark of 10 if you see a perfect figure – but if you are really being critical you won't see too many. Don't get in a rut. Guard against confining your marks in too narrow a range. If you watch carefully and mark consistently, you will find yourself giving an occasional 2, 3, or 4 on some sloppy figures that are not quite bad enough for a zero. You will also be giving an occasional 9 or 10 for the superlative figure with which you can find little or no fault. Take care not to mark on an overall impression of a flight. Be ready to award a low mark for a poor figure even if you have been marking other figures flown by that competitor with 8's and 9's.

6.5.1.2. On the other hand, when you see a competitor barely getting through the figures and you have been giving 4's and 5's, don't be afraid to award a 9 for the almost perfect 90 degree turn that you just saw.

6.5.1.3. Finally, and most importantly, only mark what you see. If you can't see anything wrong with a figure, don't deduct any points, even if you think there must be something wrong. Always give the competitor the benefit of the doubt.

6.6. Wind Correction

There are two kinds of wind correction: correction for figure geometry (shape) and correction for Aerobatic Box positioning.

6.6.1.1. The competitor is required to make the shape of all loops and part-loops within a figure perfectly round as seen by the judge on the ground. Wind correction is required for loops and part-loops within figures so that the aircraft's flight path describes a constant radius circle or part circle. Remember, the Judge marks for the roundness of the flight path. Any deviation from perfect roundness must result in a reduction of the mark for that figure.

6.6.1.2. The competitor is also required to keep the aircraft within the Aerobatic Box. This becomes more of a problem when a wind is blowing at an angle to the X axis. (Figure 5) The primary method of dealing with cross-box drift is to include a "wind corrector" figure in the sequence. A wind corrector is a figure which places the aircraft onto the Y axis. Because the Y axis is non-directional, the competitor can turn onto the Y axis in the direction which will allow an upwind position change before flying a subsequent figure which returns the aircraft to the X axis.

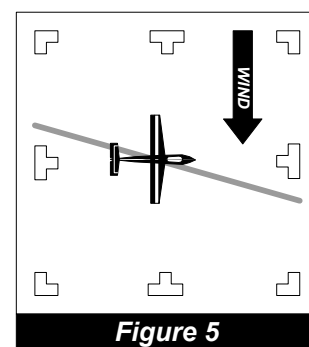

6.6.1.3. A well designed Free Program will always include at least one, and preferably more, wind corrector figures. Not every Known Compulsory or Unknown Program contains sufficient (or any) wind corrector figures. In this case, it is up to the competitor to keep the aircraft within the Aerobatic Box without benefit of a specific Y axis figure to accomplish it. A common approach is to crab into the wind as done in navigational flight. (see Figure 6) Crabbing means that the aircraft's heading is at an angle to the competition axis (X or Y). The downside to this approach is that if this heading angle can be detected by the Judge, a deduction of one (1) point per five (5) degrees will be given.

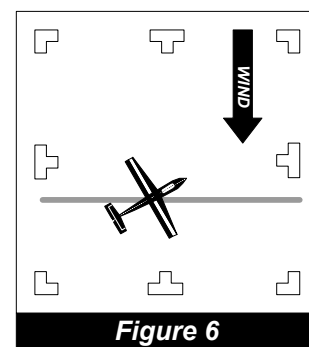

6.6.1.4. It is possible for the competitor to correct for wind in such a manner that the attitude remains absolutely true to the correct geometry of the figure but the flight path has a sideways component. It goes beyond the scope of this document to provide a tutorial on how this may be accomplished, but what is clear is that if any yaw (heading) deviation or bank angle is visible to the Judge, the mark must be reduced at the rate of one (1) point for every five (5) degrees of deviation detected.

6.6.1.5. Please note, however: even if it is plainly evident that the aircraft has moved laterally within the Aerobatic Box, if the method of that movement cannot be detected by the Judge, no deduction for such correction must be made.

6.7. The Two Basic Components Of Aerobatic Construction: Lines And Loops

6.7.1. Lines

6.7.1.1. All lines are judged in relation to the true horizon and the Aerobatic Box's axes. Horizontal lines are judged on flight path, not attitude. Different aircraft at different airspeeds will employ different attitudes to maintain a horizontal flight path. (see Figure1)

6.7.1.2. Gliders cannot maintain altitude without losing speed. In order to maintain airspeed, they must fly a descending flight path. The glide angle at constant airspeed is determined by the lift/drag ratio of the specific glider at that speed. So, depending on airspeed and glider type, glide angles may vary considerably.

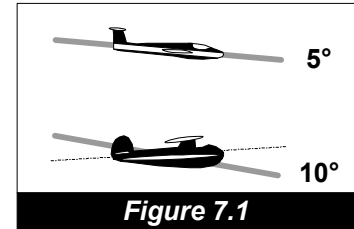

6.7.1.3. For this reason, the flight path for horizontal lines in glider aerobatics may be inclined between zero (0) and ten (10) degrees below the horizon (Figure 7.1). Deviations above or below this bracket will be downgraded by one (1) point per five (5) degrees.

6.7.1.4. While maintaining a horizontal flight path, the aircraft's heading must remain parallel to the X or Y axis. The deduction for deviation in either axis is one (1) point per five (5) degrees from the correct geometry.

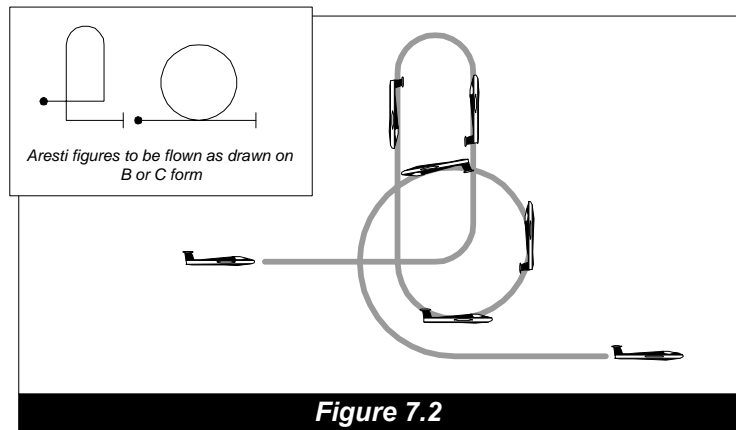

6.7.1.5. All figures begin and end on definite horizontal lines, and both must be present in order to earn a good mark. A competitor who rushes from one figure to another without showing this horizontal and well-recognizable line will be downgraded by one (1) point for each missing line in each figure affected. Therefore, leaving out the line between two figures will downgrade the preceding figure by one (1) point and the following figure by one (1) point. (Figure 7.2)

6.7.1.6. All lines that occur inside a figure are preceded and followed by part-loops. (Figure 8) The absolute length of lines within a figure is in itself not a marking criterion. The corresponding attitude, however, must be maintained long enough to allow judges to observe the angle and determine any deviations from the prescribed plane of flight.

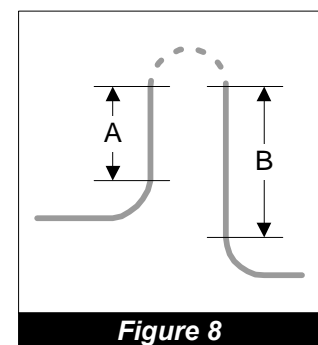

6.7.1.7. Excessively long lines must not be rewarded with higher marks and "rough" flying with high-G "square corners" must be penalized by reducing the mark for harmony.

6.7.1.8. With the exception of Family 3 figures and some figures in Family 7, the criterion for the length of lines within a figure states that they do not have to be of equal length. Therefore, it is imperative that the judges become familiar with the specific criterion for the length of lines for each figure. For example, the length of the lines in a "Humpty-bump" do not need to be equal, but all four lines in a "Square loop" must be of equal length. (Figure 9)

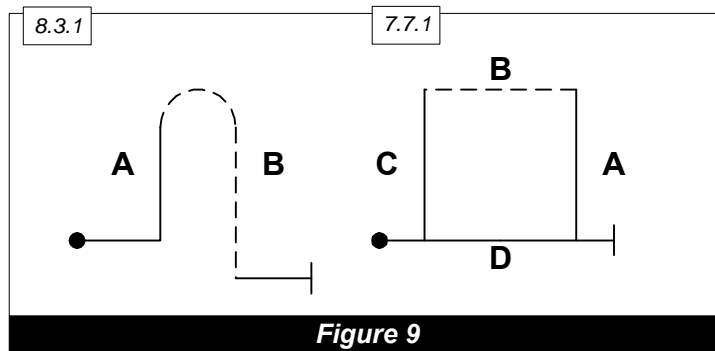

6.7.1.9. Whenever a slow roll or hesitation roll is placed on an interior line, the lengths of the two parts of the line before and after the roll must be equal. In gliders, the entry airspeeds for positive and negative flick rolls lie in a relatively narrow bracket. The pilot must be free, therefore, to determine the point on the line where he starts the flick roll. Because of this, no deduction will be made for flick rolls not centred on an interior line.

6.7.1.10. The line lengths before and after a roll are not a marking criterion when rolls are performed on a 90 degree down line following a spin.

6.7.1.11. Some gliders have relatively slow roll rates and need practically the entire length of an interior line to complete a slow roll or hesitation roll. Therefore, it is sufficient to fly vertical or 45 degree lines before and after the roll just long enough to show that the preceding part-loop has been completed and the prescribed plane of flight is established. The absolute lengths of the lines before and after the roll are irrelevant for marking as long as they are equal.

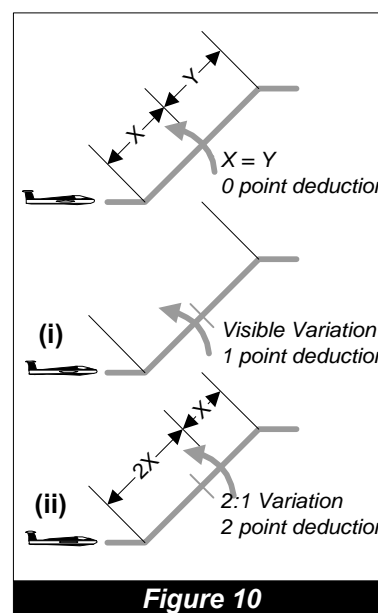

6.7.1.12. Judges should take care to judge the symmetry of the length of lines in a figure using only the length of the lines and not by elapsed time taken to fly each segment. This difference in length versus elapsed time is most noticeable in figures where rolls are placed on up-lines. As the aircraft loses airspeed, the time it takes to fly a line after the roll will be greater than the time required to fly the line of the same length before the roll.

6.7.1.13. If within a figure two or more lines must be of the same length, an observed variation is penalised by reducing the mark in the following manner: (Figure 10)

- a) a visible variation - one (1) point deduction
- b) if the lengths vary by 1:2 or more - two (2) points deduction.

6.7.1.14. The basis for judging line lengths is the first line flown. The absence of one of the lines before or after a roll is penalised by one (1) additional point.



Example: The competitor is to fly a 45 degree up-line with a half slow roll on this line. Although there was a line before the roll, the glider was returned to level flight immediately after the roll. The correct deduction is three (3) points: two (2) points are deducted because the lengths of the lines differ by more than 1:2, and another one (1) point is deducted because of the absence of one of the lines.

6.7.1.15. All 90 degree and 45 degree lines are preceded by a part-loop. When the glider completes the part-loop and reaches the prescribed plane of flight, the pilot must reduce the angle of attack to maintain the 90 degree or 45 degree attitude. For marking purposes, the judge must only look for the precise alignment of the glider's zero lift axis 45 degrees or 90 degrees relative to the horizon as soon as the part-loop has been completed.

6.7.1.16. Some pilots exaggerate the change in angle of attack when transitioning from loop to line. They overshoot the correct angle by several degrees, and then the nose of the glider is "bumped" back onto the line. Any visible "bump" in the transition from a loop or part-loop onto a line must be penalized by a one (1) point deduction.

6.7.2. Loops and Part Loops

6.7.2.1. All transitions from one plane of flight to another should have a reasonable and constant radius. The size of that radius is not a marking criterion and higher marks must not be given for high-G "square corners". If a stall occurs in a loop or part loop, the figure must be marked soft zero (0.0).

6.7.2.2. The loop is a figure from Family 7, but part-loops are integral to every other family so it is necessary to discuss the loop before going on to the other families.

- a) A loop must have, by definition, a constant radius. It starts and ends in a well-defined line which, for a complete loop, will be horizontal. For a part-loop, however, such lines may be in any other plane of flight and will be defined by the aircraft's attitude. As the speed changes during execution of a loop or part-loop, the angular velocity around the aircraft's lateral axis also has to change in order to keep the radius constant. When the speed decreases, for example, to half its initial rate, the angular velocity, to keep the same radius, will be reduced by half – this is a fact of physics. Thus, the angular velocity can be an aid for the Judge to gauge the radius – especially when the angular velocity in the higher part-loop is seen to be faster, as this is a clear indication that the radius is smaller. This aid becomes more important when two part-loops are separated by a line between.
- b) The part-loops of any one figure should all have the same radius, except in Family 1, 5 and 6 figures and where indicated in Family 8.1 thru 8.20 and 8.49 thru 8.56. For example, a figure starts on a horizontal line, with a quarter loop next, followed by a vertical line and then another quarter loop. The quarter-loop at the top of the vertical line (Family 1 figures) need not have the same size radius as the quarter-loop at the bottom. However, the top radius must not be a "corner" or very sharp angle. It must have a smooth, distinct and constant radius.

6.8. Aresti System (Condensed) Glider Families

6.8.1. Family 1 – Lines and Angles

6.8.1.1. Family 1.1 to 1.11 has been fully covered in the preceding section. Note that the figures in Family 1.12 to 1.31 are NOT performed as drawn in the Catalogue. (Figure 12) In each of these figures there are three (four in 1.28 - 1.31) looping components: a one-eighth loop, a three-eighths loop and a quarter loop. (Figure 13) Rolls may be performed on the 45 degree line and/or the 90 degree line, with the part-lines before and after the roll being of equal length, except positive or negative flick rolls and rolls following a spin.

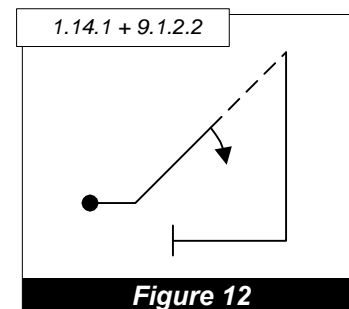

Figure 12

6.8.1.2. The initial horizontal line and the line at the end of the figure may be flown at different altitudes.

6.8.1.3. Figure 13 shows Family 1.12-1.19 as flown. Radii *a*, *b*, and *c* may all be different and entrance altitude "A^a" can be different from exit altitude "B".

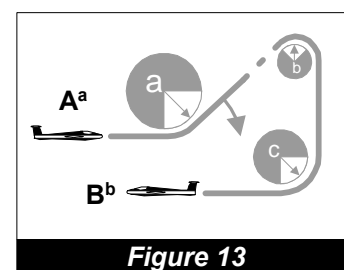

Figure 13

6.8.2. Family 2.1 - 2.2 Turns

6.8.2.1. Competition turns are not to be confused with standard coordinated turns (Figure 14). In aerobatic competition, a turn is divided into three parts:

- establishing the bank using a roll on heading;
- the turn itself; and
- a roll back to straight and level flight on heading.

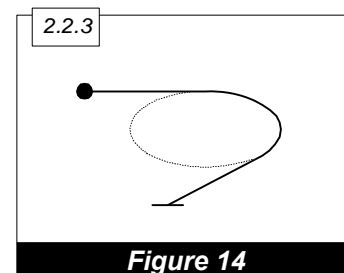

Figure 14

6.8.2.2. First, the roll to establish the bank. This must be a roll of 60 degrees, it must be performed on the entry heading, and the aircraft must maintain a constant glide (0 to 10 degrees below the horizon).

6.8.2.3. Once the roll is completed and the angle of bank is established, the competitor immediately performs the turn. The turn must maintain 60 degrees of bank throughout. The aircraft must also maintain a constant glide (0 to 10 degrees below the horizon). The rate of turn is constant throughout and is NOT wind corrected. Therefore, in wind, a 360 degree turn will not appear as a perfect circle.

6.8.2.4. As soon as the glider is on the exit heading, the competitor performs another roll at a rate equal to the entry roll. Again the aircraft must maintain a constant glide (0 to 10 degrees below the horizon).

6.8.2.5. Downgrades:

- The angle of bank established by the initial rolling manoeuvre must be exactly 60 degrees. Any deviation is a one (1) point deduction for every five (5) degrees.

- b) The angle of bank, once established, must remain constant. Any deviation is a one (1) point deduction for every five (5) degrees of deviation.
- c) The rate of roll must be the same for the entry and exit rolls of this figure. Any deviation is a one (1) point deduction.
- d) The aircraft must maintain a constant glide (0 to 10 degrees below the horizon) throughout the figure. Any deviation above or below is one (1) point for every five (5) degrees.
- e) The rate of turn must remain constant. Any change would be not more than a one (1) point deduction for each change. Note that the rate of turn may appear to change in a strong wind, when it really isn't changing. The Judge must always keep the wind in mind and give the pilot the benefit of the doubt if there is any question.
- f) The aircraft must begin and end on the prescribed heading. Any deviation is a one (1) point deduction for every five (5) degrees of deviation.

6.8.3. Family 2.3 - 2.20 - Rolling Turns

6.8.3.1. The rolling turn is a figure that combines a turn of a prescribed amount with a roll or rolls integrated throughout the turn. (Figure 15).

6.8.3.2. These rolls may be in the same direction as the turn and are called "rolls in" or "rolls to the inside". They can be rolls in the opposite direction of the turn and are called "rolls out" or "rolls to the outside". Or there can be rolls alternating in and out.

6.8.3.3. When we say that the rolls are integrated, we are saying that in addition to there being a constant rate of turn throughout the figure, There must also be a constant rate of roll and the rolls must be synchronised with the turn..

6.8.3.4. For example: In a 180 degree rolling turn with two rolls from upright (Catalogue Numbers. 2.6.1 or 2.6.3) the glider must be inverted after 45 and 135 degrees of turn and upright at 90 and 180 degrees.

6.8.3.5. At the end of the figure the aircraft must be wings level and on the prescribed heading.

6.8.3.6. When a rolling turn is performed with rolls alternating directions, the aircraft must change direction of roll at a wings level attitude whilst continuing the turn. There must be no recognizable pause when reversing roll directions.

6.8.3.7. Downgrades:

- a) Performing more or fewer rolls than the catalogue description calls for results in the figure being HZ.
- b) All rolls in a rolling turn are slow rolls. If, in the judge's perception, a flick roll is flown or a stall occurs, the figure is graded soft zero (0,0).
- c) Each visible variation of the roll rate as well as the turn rate is a downgrade of no more than one (1.0) point.

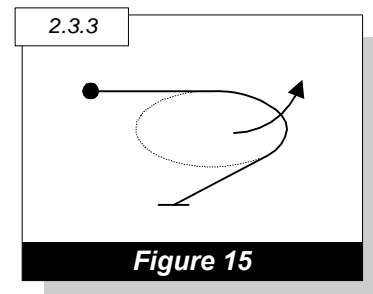

- d) Each stoppage of the rate of roll as well as the rate of turn is a downgrade of no more than two (2.0) points.
- e) A recognizable pause when reversing roll directions will be downgraded by one (1) point.
- f) Variations from the constant glide (0 to 10 degrees below the horizon) are deducted by one (1) point per five (5) degrees.
- g) One (1) point for every five (5) degrees of bank when reversing roll direction.
- h) One (1) point for every five (5) degrees of roll remaining when the aircraft has reached its exit heading.
- i) One (1) point for every five (5) degrees of turn remaining when the aircraft has completed its last roll.

6.8.4. Family 3 – Combinations of Lines

6.8.4.1. The transition from level flight to 45 degree lines should be at a constant and reasonable 1/8 looping radius. All lines within the figure should be equal in length. The 45 degree transitions in Family 3.1 should have a constant and reasonable radius and not (as drawn) a sharp corner. (Figure 16)

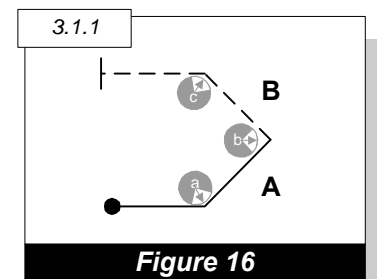

6.8.5. Family 5 - Stall Turns

6.8.5.1. Stall turns are some of the most graceful figures in the catalogue. In its most basic form (Figure 17), the figure begins when the aircraft leaves horizontal flight and flies a quarter loop to establish a vertical climb. At the top of the vertical line, the aircraft pivots and establishes a vertical descent, with the figure ending as the aircraft is returned to horizontal flight.

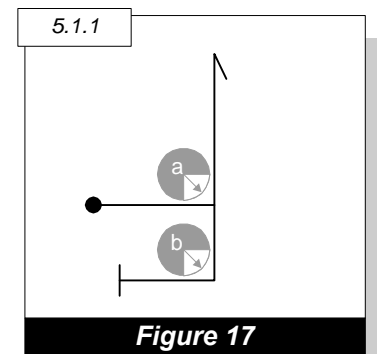

6.8.5.2. The judging criteria are:

- a) The entry and exit quarter loops must be flown with a reasonable and constant radius.
- b) The vertical lines, both up and down, must be flown on the zero-lift axis. (see Figure 2)
- c) Any deviation from vertical, either up or down, will result in a deduction of one (1) point per five (5) degrees from the zero lift axis.
- d) Any added roll(s) must be in the vertical climb or vertical descent and positioned so that the lines before and after the roll are of equal length (except positive or negative flick rolls) (Figure 18). For deductions see 6.7.1.13.

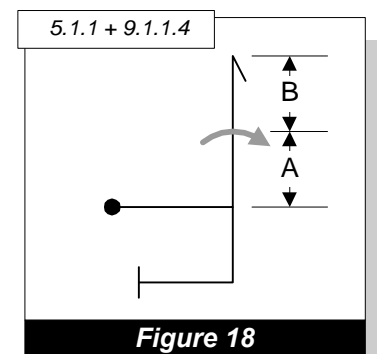

- e) The length of the vertical up and down lines need not be equal. As such, the altitude of the horizontal lines at the start and finish of the stall turn may be different.
- f) During the vertical climb or vertical descent, the wings must remain parallel to the horizon. There will be a one (1) point deduction per five (5) degrees, when the line connecting both wing tips deviates from horizontal.
- g) As the glider nears the point where it would stop climbing, it must pivot in a plane parallel to vertical. To avoid a deduction, it must pivot around a point which should not be farther away from its centre of gravity than its wingtip. When the radius of the rotation is greater, the downgrade is one (1) point per half wingspan. (Pivot Point D, Figure 19)
- h) The rate at which the aircraft pivots around its vertical axis is not a judging criterion. If, however, the glider slides down sideways whilst pivoting around its vertical axis, this "wing slide" must be downgraded by at least one (1) point depending on the severity of the slide.
- i) The wings must remain in the vertical geometric plane throughout the turnaround, and the aircraft's attitude before and after the turnaround must be absolutely vertical, with no pitch or roll. There must be no rotation around the longitudinal or lateral axes. If there is movement around any axis other than the yaw axis, often referred to as "torquing" (Figure 20), there is a deduction of one (1) point for each five (5) degrees off axis.

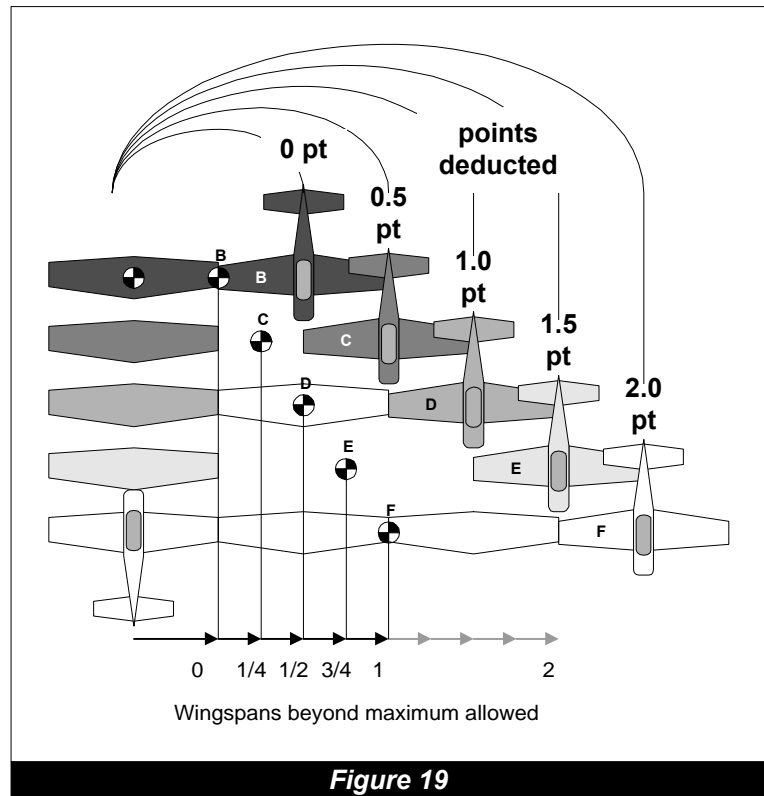

Figure 19

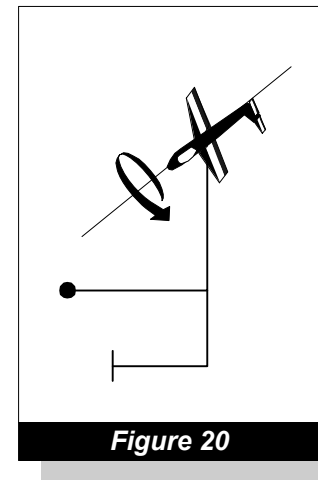

Figure 20

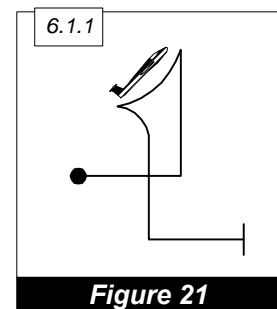

Figure 21

6.8.6. Family 6 – Tailslides

- 6.8.6.1. All the criteria of the Stall Turn apply to this figure except, of course, for the manoeuvre at the top of the vertical climb. At the point when the aircraft stops, it must slide backwards a visible amount (the key here is "a visible amount"). If there is no slide, the grade is soft zero (0.0).

6.8.6.2. Following the slide backwards, the aircraft must then tip over and fall through to a diving position. The tipping over must be around the lateral axis only. Any movement around another axis is downgraded by one (1) point per five (5) degrees.

6.8.6.3. Often the nose will swing back or "pendulum" past the vertical after falling through. The figure is not to be downgraded for this, nor downgraded if it does not happen. It is a function of the length of the slide and the type of aircraft, and is not to be considered in marking the figure.

6.8.6.4. There are two types of tailslides: wheels-down (also called "canopy-up") and wheels up (also called "canopy-down"). The wheels-down tailslide is depicted in the Aresti diagram with a curved solid line at the top of the tailslide symbol. (Figure 21) The wheels-up tailslide is depicted in the Aresti diagram with a curved dashed line at the top of the tailslide symbol. (Figure 22)

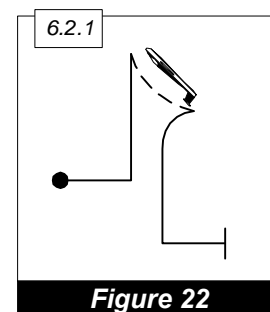

6.8.6.5. This figure must be watched carefully, as the aircraft can fall the wrong way (which is marked Hard Zero) with the correct direction of flight and the proper aircraft attitude still maintained. Wings should stay level with the horizon throughout and not drop during the slide or the fall through. Watch for the aircraft rolling off the correct plane of flight, which must be downgraded.

6.8.6.6. Also watch for "cheating" on the vertical line up in the direction of the slide just prior to sliding. (Figure 23) The entry quarter loop and the exit quarter loop must be flown with reasonable and constant radii. The altitude of the entry and exit horizontal lines need not be the same and the figure must not be downgraded if they are different.

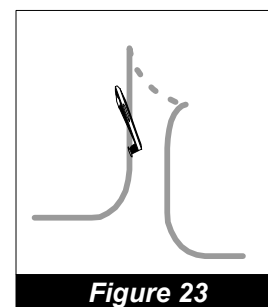

6.8.6.7. When rolls are combined with Family 6 figures, there must be an equal length of line before and after the roll(s) (except positive or negative flick rolls). In the vertical down line, the aircraft must attain a vertical attitude and establish a down line before starting the roll(s).

6.8.6.8. In summary, the aircraft should make a smooth and steady transition up to vertical flight, the wings should stay level in relation to the horizon, and the aircraft should come to a complete stop in this attitude. After sliding backward a visible amount, it should fall through in the appropriate direction without dropping a wing or the nose moving off axis, and recover on the same plane as that of entry. After completion of this, it should again project the 90 degree down line before transitioning into horizontal flight with a quarter loop of reasonable and constant radius.

6.8.7. Family 7 – Loops and Figure 8's

6.8.7.1. The size of a loop is not a marking criterion. It will vary according to the flight characteristics of the aircraft. A large loop is not marked any higher or lower than a small loop. But any variation to the radius will downgrade these figures.

6.8.8. Family 7.1 - 7.4 - Half-Loops With Rolls

6.8.8.1. The half-loops in this sub-family must be of a constant radius and wind-corrected to appear as a perfect half circle (see full loops discussion below).

6.8.8.2. When a half-loop is preceded by a roll or rolls, the half-loop follows immediately after the rolls without any visible line. Drawing a line requires a downgrade of at least two (2) points depending on the length of the line drawn. Should the half-loop begin before the roll is completed, the Judge must downgrade the figure one (1) point for every five (5) degrees of half-loop flown on which the roll was performed.

6.8.8.3. The half-loop followed by a roll is also flown with no line between the half-loop and roll. Again, drawing a line requires a downgrade of at least two points depending on the length of the line drawn. Should the roll begin before the half-loop is completed, the Judge must downgrade the figure one (1) point for every five (5) degrees of half-loop on which the roll was performed. (Figure 24)

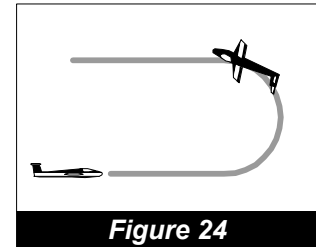

Figure 24

6.8.9. Family 7.5 - 7.6 - Full Loops

6.8.9.1. All full loops must appear perfectly round to the Judge. This means that they must be wind corrected to have a constant radius. This wind correction is only with regards to the roundness of the loop and not for the effect of any crosswind on the figure. Therefore, no deduction is given if the finish point is displaced relative to the start point in a direction perpendicular to the plane of the loop. Full loops must also begin and end at the same altitude or they will be downgraded. (Figure 25.1)

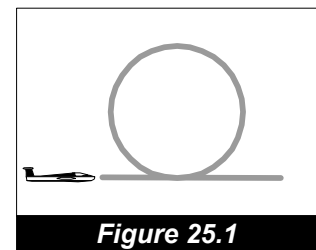

Figure 25.1

6.8.9.2. In glider aerobatics, the entry and exit lines of the loop may be inclined 0 to 10 degrees below the horizon and the inclination may be different for entry and exit lines within the above tolerances (Figure 25.2).

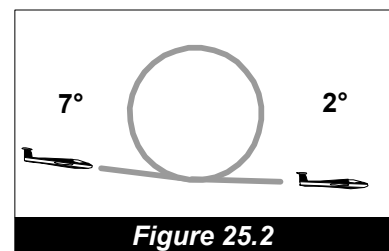

Figure 25.2

6.8.9.3. Loops must be flown with no visible crabbing and wings must be level at all times. The one (1) point for every five (5) degrees rule holds for both these cases.

6.8.9.4. If there is a roll or rolls at the apex of the loop, it must be centred in the loop and flown on the arc of the loop itself. Flying the roll on a line at the apex of the loop is at least a two (2) point downgrade. If the roll is not centred, it must be downgraded one (1) point for every five (5) degrees of the arc that it is off centre.

6.8.9.5. To better quantify deductions for irregularity of the radius of looping figures, the Judge divides the loop into quadrants. Any variation in the radius from one quadrant to the next can be downgraded a fixed number of points depending on the magnitude of the variation.

6.8.9.6. The goal of each Judge is to develop a reproducible method to judge all loops with the same criteria. In judging loops, a common error is for the vertical diameter of the loop to be larger than the horizontal diameter. This is often called an "L" shaped loop (Figure 26).

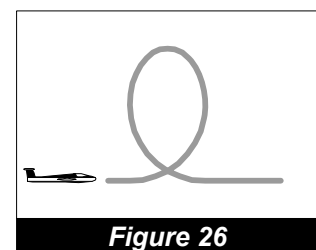

Figure 26

6.8.9.7. Less common are loops with a horizontal diameter greater than the vertical. This is called an egg-shaped or pumpkin-shaped loop (Figure 27).

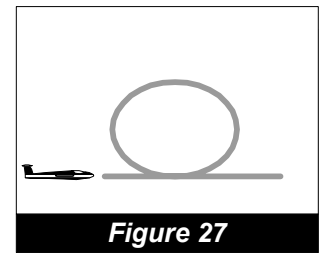

Figure 27

6.8.9.8. Another common error is in varying the radius of the final quadrant performing an "e" shaped loop (Figure 28).

6.8.9.9. Whatever method is used, standard downgrades should be applied for each of these errors. Additional downgrades should be applied based on the magnitude of variation.

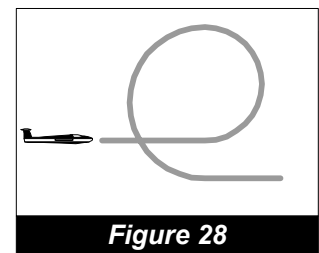

Figure 28

6.8.10. Family 7.7 - 7.10 - Square, Diamond and Octagon Loops

6.8.10.1. Square and Octagon loops are flown as hesitation loops with lines of equal length and partial loops with equal radii. All horizontal lines are judged on flight path and vertical and diagonal lines are judged based on aircraft attitude. As such, except in a windless condition, the judge should never expect to see these figures closed. They will always be driven by the wind. Square and Octagon loops are not considered complete until the last horizontal line is drawn equal to the length of the first line of the figure.

6.8.10.2. In Figure 29:

- a) Radii $a = b = c = d$
- b) Line Length $A = B = C = D$
- c) Figure is not complete until $D = A$

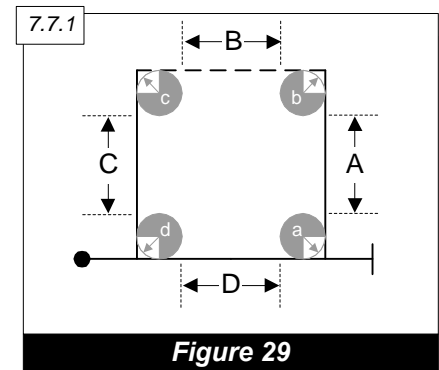

Figure 29

6.8.10.3. Where rolls are flown on the Square or Diamond loops, they must be centred on the line (except positive or negative flick rolls).

6.8.10.4. Aids for judging all hesitation loops are that a good performance will contain changes of angular velocity in all the partial loops, and variations of time taken to draw the length of each interior line, which also varies according to the aircraft's speed. The rhythm of all these partial loops is a help for judging. A frequently seen error in hesitation loops is for the aircraft to overshoot the partial loop and then have to bring the nose back to correct the attitude. This must be downgraded by one (1) point for every five (5) degrees.

6.8.11. Family 7.19 - 7.22 - Partial 8's

6.8.11.1. Sometimes referred to as "Goldfish", the entry and exit radii in these figures must all be identical. However, the $\frac{3}{4}$ loop can be of a different but constant radius. The entry and exit lines are judged with reference to the 45 degree attitude, not flight path. Any rolls, except positive or negative flick rolls on the 45 degree lines must be centred on that line. It is not required that the lengths of the 45 degree lines bear any strict relation to the diameter of the three quarter loop. That is, the entry and exit altitudes need not correspond to the altitude limits of the loop. (Figure 32)

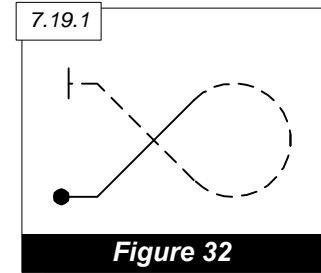

6.8.12. Family 7.23 - 7.30 - Horizontal 8's

6.8.12.1. Both loops must be the same size and the lines between the loops flown at exactly 45 degrees attitude. This means that only if there is no wind will they intersect at the exact midpoint of the 8. If there are rolls of any variety, they will only occur on the 45 degree lines and, except positive or negative flick rolls, be positioned so that the lines before and after the roll are of equal length. For deductions see 6.7.1.13.

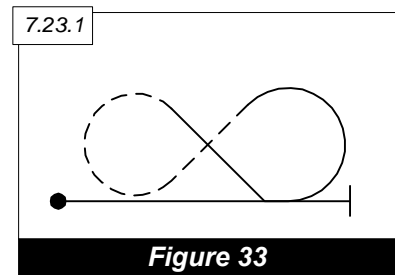

6.8.12.2. The start and finish of the figure and the bottoms (or tops if the figure is reversed) of the two loops need not be at the same altitude.

6.8.12.3. The radius of the part-loop between 45 degree and horizontal need not equal the radii of the loops of the Horizontal 8 itself. A common fault is to fly these part-loops as drawn in the catalogue symbol, which means with a corner. This must be downgraded. (Figure 33)

6.8.13. Family 7.31 - 7.38 - Combination 8's

6.8.13.1. Besides possessing the unique characteristic of containing three 45 degree lines on which rolls may potentially be placed, these sub-families should be judged as 7.23 to 7.30 but with the addition of an extra 45° line.

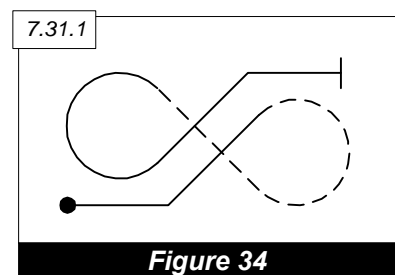

6.8.13.2. Radii of the entry/exit 1/8th loops must be equal and the radii of the two 3/4 loops must be equal. However, the radii of the entry/exit 1/8th loops need not equal the radii of the internal $\frac{3}{4}$ loops. Each of the 45 degree lines may be of different lengths, but any rolls except positive or negative flick rolls placed on them must be centred. The two 3/4 loops need not occur at the same altitude, nor is there any strict relationship between the horizontal entry/exit altitudes and the altitude limits of the two 3/4 loops. (Figure 34).

6.8.14. Family 8 – Combinations of Lines, Loops and Rolls

6.8.14.1. These figures are combinations of horizontal, vertical and 45 degree lines as well as partial loops of varying degrees. The judging criteria for these lines and loops are unchanged. What is left to discuss are the judging criteria for the combinations of these lines and loops.

6.8.15. Family 8.1 – 8.28 – Humpty Bumps

6.8.15.1. These figures, whether vertical or performed with 45 degree lines, are judged as combinations of lines and loops. For all these figures, the radii of the first and last partial loop must be equal. However, the half loop in the middle of the figure can be of a different radius. These half loops must still have a constant radius from the time they depart the vertical or 45 degree line. This requires a change in angular velocity during the half loop. (Figure 35)

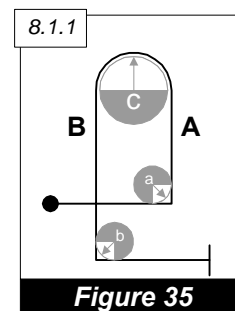

Figure 35

6.8.15.2. The lines in these figures may be of different lengths, and therefore the entry and exit altitudes of these figures can be different. Rolls on any of these lines except positive or negative flick rolls and rolls following a spin must be centred.

6.8.16. Family 8.29 - 8.48 and 8.51 - 8.54 - 7/8 Loops, Reverse Half Cubans, 3/4 Loops, Half Cubans

6.8.16.1. In these figures, all partial loops must have the same radii. The rolls on vertical and 45 degree lines except positive or negative flick rolls and rolls following a spin must be centred. Horizontal rolls immediately preceding or following looping segments have the same criteria as in Families 7.1 to 7.4. (Figure 37) Angles drawn in the GAF Catalogue, are to be flown as partial loops.

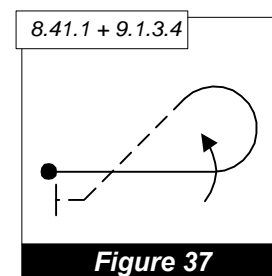

Figure 37

6.8.17. Family 8.49 - 8.56 - Multiple Looping Combinations

6.8.17.1. When 1/4, 1/2 and 3/4 loops join each other in these sub-families, their radii must be equal and there is no line between the loops. (Figure 38) A line drawn would be a minimum two (2) point deduction depending on the length of the line. An exception is the 1/4 loop that returns the aircraft to horizontal flight, which should have a reasonable radius, but need not match the other looping radii.

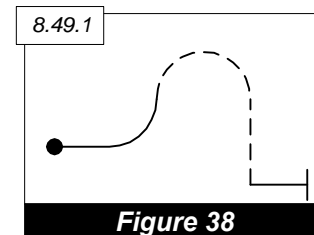

Figure 38

6.8.18. Family 8.57 - 8.68 – Teardrops

6.8.18.1. In these figures, all partial loops must have the same radii. The rolls on vertical and 45 degree lines except positive or negative flick rolls and rolls following a spin must be centred. Angles drawn in the Catalogue are to be flown as partial loops. (Figure 39)

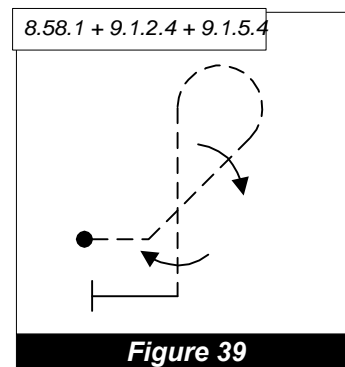

Figure 39

6.8.19. Family 9 – Rolls and Spins

6.8.19.1. Rolls may be performed on horizontal, 45 degree or 90 degree lines; on complete loops; between part-loops; between part-loops and lines; and following spin elements.

6.8.19.2. They may be 1/4, 1/2, 3/4 or a full 360 degrees in their rotation, up to two consecutive full rolls. Additionally, slow rolls may be flown in combination with turns as prescribed in Family 2 (Rolling Turns).

6.8.19.3. In all cases, the same criteria apply: the rate of roll must be constant throughout the roll(s). The aircraft should continue to project, during the rolling portion, the prescribed plane and direction of flight.

6.8.19.4. Multiple rolls may be linked, unlinked, or opposite.

a) When rolls are in continuous rotation, the tips of the symbols are linked by a small line. When flying linked rolls there is no pause between them. (Figure 40)

b) Unlinked rolls must be of different types, the two types being defined as follows:

- i) Aileron rolls (slow rolls and hesitation rolls)
- ii) Flick rolls (positive and negative)

c) With unlinked rolls, no line links the symbols, though their tips are drawn pointing in the same direction (i.e., on the same side of the line). They must have a brief but perceptible pause between them and they are to be flown in the same direction of rotation. (Figure 41)

d) Opposite rolls may be either of the same or different type. In opposite rolls, the tips of the symbols are drawn on opposite sides of the line, indicating they are to be flown in opposite directions of rotation. The pilot may elect to fly the first roll in either direction, but the second roll must be opposite direction to the first. Opposite rolls, including those in rolling turns, should be flown as one continuous manoeuvre - the brief check between opposite rotations should be minimal. (Figure 42) If the two rolls are of the same type, they must be flown in opposite directions if they are not linked.

e) Either aileron or flick rolls may follow spin elements (Family 9.11 or 9.12). When a spin and a roll are combined on the same vertical down line they will always be unlinked; may be flown in either the same or opposite direction, as shown by the position of the tips of the symbols on the Form B or C; and the combination may not exceed two rotational elements. (For example, it would be illegal to combine two opposite direction aileron rolls with a spin element.)

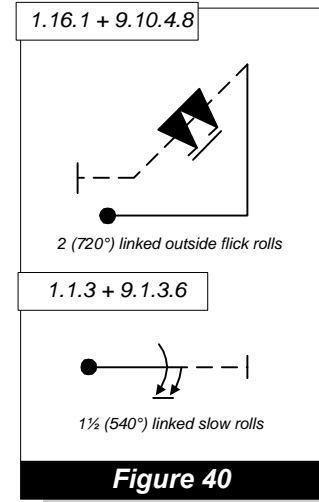

Figure 40

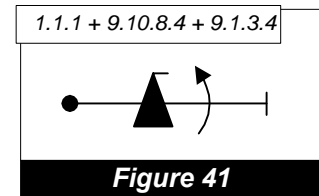

Figure 41

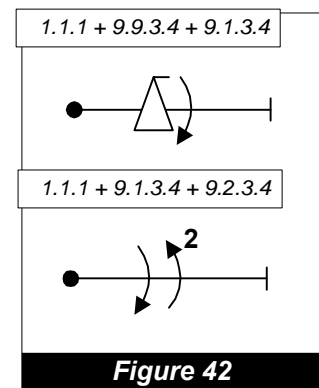

Figure 42

6.8.20. Families 9.1 and 9.13 - Slow Rolls and Super-Slow Rolls

- 6.8.20.1. The penalty for varying the rate of roll is one (1) point per variation. Any stoppage in the slow roll that could result in its being considered a hesitation roll, would hard zero (HZ) the figure. The finish of the roll must be as crisp and precise as possible. Coming to a slow finish in fact represents a change in the rate of roll and should be penalized accordingly.
- 6.8.20.2. The marking criteria for Super-Slow Rolls are identical to Slow Rolls, but the average rotation rate of Super-Slow Rolls must not be more than 36 degrees per second (minimum 5 seconds for one half roll; 10 seconds for one roll; 15 seconds for one and one half roll)
- 6.8.20.3. The wings must stop precisely after the desired degree of rotation and not go past the stop point and then return. This is referred to as "bumping the point". A deduction of 0.5 point to one (1) point is given depending on the severity of the "bump"

6.8.21. Family 9.2 - 9.8 - Hesitation Rolls

- 6.8.21.1. These rolls are judged on the same criteria as the slow roll, only the aircraft stops rotation during the roll for a pre-stated number of times, i.e., 2, 3, 4 or 8. The rate of the roll and the rhythm of the hesitations must be constant throughout with the aircraft projecting the pre-stated plane and direction of flight. The pauses will be of identical duration and the degree of rotation correct between each pause: 180 degrees, 120 degrees, 90 degrees, or 45 degrees. Each pause of a hesitation roll must be clearly recognizable in every case, but it is especially important that in poor visibility or at high altitude, the competitor pauses long enough to make them recognizable to the Judges. If a pause is not recognizable to a judge, the figure is marked a Hard Zero (HZ).
- 6.8.21.2. "Bumping the point" will be downgraded by 0.5 point to one (1) point depending on the severity of the "bump" for each occurrence.

6.8.22. Family 9.9 - Positive Flick Rolls

- 6.8.22.1. Flick rolls represent one of the greatest challenges to judges. This is primarily due to two factors: (1) the "flicking" characteristics of different types of aircraft are unique; and (2), flick rolls are a high energy manoeuvre that occur very quickly. Flicks happen so fast, in fact, that it is virtually impossible for a judge to determine the exact order in which events occur, especially at the beginning of the flick. There are no criteria, therefore, for seeing nose and wing movement initiated at the same time as with the other autorotation family, Spins.

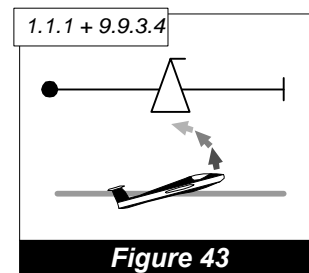

Figure 43

- 6.8.22.2. The judge must see two things to determine that a flick roll has occurred. The nose must depart the flight path and autorotation must be initiated. If the judge does not observe both events, the figure must be given a soft zero (0.0). Another important clue is rate of roll: in most gliders it is considerably faster when flicked than when rolled by ailerons.
- 6.8.22.3. For a positive flick roll, the nose must move away clearly and unambiguously from the wheels (Figure 43). This puts the aircraft's wings near the critical angle-of-attack. If the nose moves in the wrong direction, a Hard Zero (HZ) must be given. Either shortly after the nose moves, or simultaneously with the nose movement, the aircraft must be seen to yaw around its vertical axis, thus initiating a stall of one wing and subsequent autorotation. If any

movement about the longitudinal (roll) axis is observed before the autorotation starts, the figure is downgraded one (1) point per five (5) degrees of roll.

6.8.22.4. Throughout the flick roll, the main axis of the flick roll's rotation must be in the correct plane and direction of flight. However, the type of motion (angle-of- attack and angular velocity) displayed around the main axis of autorotation differs between aircraft types (much as each type of aircraft has different spin characteristics). If the character of the flick roll changes during the figure, the figure is downgraded. (see Family 9.1) A changing rate of rotation or the nose moving more onto the flight path (like a slow roll) is the most often observed change in character. But for all aircraft types, the criteria for stopping the flick roll is the same: the attitude before starting the flick roll and in the instant of stopping it must be identical and must correspond to the geometry of the basic figure on which the flick roll is performed.

6.8.22.5. Flick rolls must be observed very carefully to ensure that the competitor is not "aileroning" the aircraft around its longitudinal axis. The movement of the aircraft's nose departing the flight path prior to autorotation is a good clue to the proper execution of a flick roll. When a glider does not stall, it will follow a spiral flight path similar to a high-rate barrel roll. As always, the competitor is given the benefit of the doubt, but if a judge is certain that a proper flick roll has not been executed, a soft zero (0.0) is given. Another common error is for the aircraft to autorotate, but to not stay in autorotation until the end of the figure. In this case, a deduction of one (1) point for each five (5) degrees of rotation remaining when the autorotation stops must be made. If autorotation ends with more than 45 degrees of rotation remaining, even if the roll is completed with aileron, the flick roll is soft zeroed.

6.8.23. Family 9.10 – Negative Flick Rolls

6.8.23.1. For negative flick rolls, all criteria stated for positive flick rolls apply except, of course, that the aircraft is in a negative rather than positive angle-of-attack during autorotation.

6.8.23.2. Therefore, in a negative flick roll the nose of the aircraft will move toward the wheels as it departs the line of the aircraft's flight path. (Figure 44) This direction of motion must be observed very carefully, since it is the defining characteristic that differentiates a negative flick roll from a positive flick roll. As with positive flick rolls, if the nose does not move in the correct direction, it is not a negative flick roll and the figure must be given a Hard Zero (HZ).

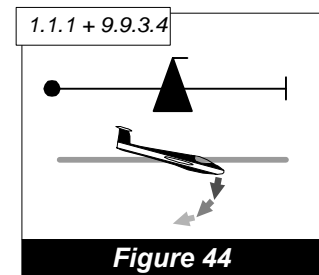

6.8.24. Family 9.11 and 9.12 – Spins

6.8.24.1. Spin elements may be combined with any Family 1 or Family 8 figure which begins on a vertical down line. Rolls may follow a spin on the same line.

6.8.24.2. All spins start from horizontal flight. In order to spin, the aircraft must be completely stalled on a clearly visible horizontal line near its minimum airspeed. In a correct spin entry, the nose of the glider drops and autorotation starts

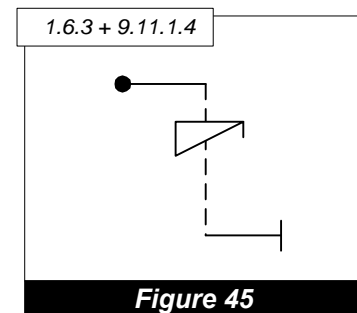

simultaneously around the longitudinal and vertical axes. If autorotation around the vertical axis is visibly delayed in relation to the roll around the longitudinal axis, entry airspeed was too high, the glider was “flicked” into the spin and the figure must be marked soft zero (0.0).

6.8.24.3. During spin entry and in the spin, the flight path is affected by wind. When the spin is entered with a tailwind, the flight path may suggest that the spin entry was "forced". This change in appearance is not a marking criterion. (Fig. 46)

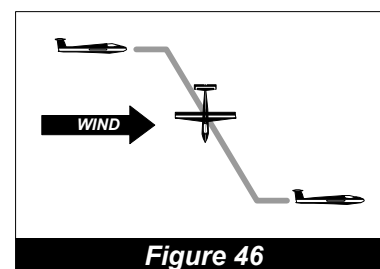

Figure 46

6.8.24.4. After completion of the prescribed number of turns, the aircraft must stop rotating precisely on the pre-stated heading, then a 90 degree down, wings-level attitude must be seen. Marking criteria for the basic figure being flown then resumes. If a roll follows a spin, there should be a brief, but perceptible pause (similar to unlinked rolls) between the spin and the roll. Because there is no vertical line before the spin, there is no criteria to centre either a spin element alone or a spin-roll combination on the vertical down line.

6.8.24.5. Be alert for early stopping of the stalled autorotation followed by "aileroning" to the pre-stated heading. In this case, a deduction of one (1) point for every five (5) degrees of "aileroning" must be applied. For example, in a one-turn spin the autorotation is observed to stop after 345 degrees of rotation and the ailerons are used to complete the rotation. The highest score this spin could receive is a 7.0. The same obviously applies for over-rotating and correcting back to the prescribed heading.

6.8.24.6. No account is to be taken of the pitch attitude of the aircraft during autorotation, as some aircraft spin in a nearly vertical pitch attitude while others spin quite flat in conventional spins. Speed of rotation is also not a judging criterion. If the aircraft never stalls, it is apparent that it cannot spin, and a soft zero (0.0) must be given. You will see "simulated" spins where barrel rolls or flick rolls are offered as spin entries. In both cases, the flight path will not be downward. In all of these cases, the figure will be zeroed.

6.8.24.7. In all spins the marking criteria are:

- a) A clean breaking stall in horizontal flight.
- b) Fully-stalled autorotation.
- c) Stopping on pre-stated heading.
- d) 90 degrees down, wings-level attitude after stopping on heading.

6.9. Positioning

6.9.1.1. Positioning is marked in one of two ways: mechanically, by means of a tracking device, or by the individual judges. When it is marked by a judge, a lower K factor is applied.

6.9.1.2. Positioning refers to the placement of the figures in relation to the X and Y axes of the performance zone. Additionally, positioning relates to the placement of each figure at its optimum distance from the judges, taking into account the height of the glider and the



nature of the figure being flown. Lastly, positioning also refers to the symmetrical placement of the entire sequence in relation to the lateral (Y) axis of the performance zone.

6.9.2. Optimal Placement of Figures

6.9.2.1. Accurate flying is best assessed when the judge's sight line is neither too high nor too low above the horizon. On the other hand, a glider continuously loses height whilst flying an aerobatic sequence. In practise this means for the pilot, in order to place his figures optimally that he should not fly too close to the forward edge of the performance zone whilst high up and not too far away from the judges toward the end of the sequence at lower altitude.

6.9.2.2. This must also consider the character of the figure flown. For example:

- a) A loop or 45 degree line cannot be judged accurately when flown too close to the judges.
- b) A rolling turn at low altitude, flown away from the judges, is much harder to assess than flown towards the judges.

6.9.2.3. If a figure is flown in a position where it is difficult to assess, the judge may deduct one half to one (0.0 to 1.0) from the positioning mark for each occurrence.

6.9.3. Sequence Symmetry

6.9.3.1. A sequence should be flown so that it is symmetrically placed in relation to the lateral (Y) axis of the performance zone. Particularly under wind influence, the pilot must try hard to balance his sequence so it remains centred on the lateral axis.

6.10. Harmony

(See paragraph 5.1.5)

6.10.1.1. The harmony of a glider program is judged on the following criteria:

- a) Energy management,
- b) Appropriate and even rhythm,
- c) Figure separation,
- d) Figure spacing,
- e) Directional control.

6.10.1.2. The basic idea behind the Harmony mark is to measure the quality of those aspects of a glider sequence which are not covered by the marks for the individual figures nor the positioning mark.

6.10.1.3. Excessively hard. High-G manoeuvring in a glider programme is poor energy management and violates the principle of harmony. If a pilot flies unnecessarily hard pull-ups or shows excessively long vertical and/or 45 degree lines throughout his sequence, the harmony mark should be reduced by two (2.0) points.



- 6.10.1.4. The entry airspeed for the next figure should be established upon exiting the preceding figure (5.1.5.1). If a pilot uses the lines between figures to gain or dissipate speed, this indicates poor energy management and must be reflected in a reduced harmony mark.
- 6.10.1.5. Changing the flight path angle within an entry/exit line is also one half (0.5) point per occurrence.
- 6.10.1.6. There will be no downgrade on harmony if the competitor is forced to gain or dissipate speed between figures due to inharmonious construction of a compulsory programme (5.1.5.1)
- 6.10.1.7. Another important factor of harmony is an appropriate and even rhythm throughout a glider programme. The competitor should fly his figures with clear separation and even spacing. The lines between figures must have a constant flight path angle and should be of even length, taking into account varying speeds. Flying unduly long horizontal lines or lines of greatly varying length, as long as this is not necessary to compensate for strong winds (paragraph 5.1.5.1.b), should be downgraded by one half (0.5) point per occurrence.
- 6.10.1.8. A programme interruption must result in a reduction of the harmony mark by two (2.0) points. If the judge is overruled on a programme interruption, his harmony mark will nevertheless not be adjusted afterwards.
- 6.10.1.9. Good directional control is paramount for harmony. If there is a directional deviation greater than 45 degrees in a figure or coming out of a figure and the competitor must correct his alignment in the horizontal plane, the harmony mark should be reduced by one (1.0) point per occurrence. When this correction is done in the vertical plane, even if the figure is zeroed for directional deviation, it will not influence the harmony mark.
- 6.10.1.10. Any figure flown in the wrong direction reduces the harmony mark by one (1.0) point. If the judge is overruled on this HZ, the harmony mark must not be adjusted afterwards.
- 6.10.1.11. Hard Zeros given for any other reasons (omitted figures, wrong figures, figures started behind the judges etc.) have no influence on the harmony mark.



7. CODE OF PRACTICE FOR THE CHIEF JUDGE AND BOARD OF JUDGES AT WORLD AND CONTINENTAL AEROBATIC CHAMPIONSHIPS

7.1. Chief Judge

- 7.1.1.1. The Chief Judge's primary concern should be the accurate and fair judging of the competition flights, including the monitoring of flights for Hard Zero marks and penalties. He should place his expertise at the disposal of the Board of Judges, and coordinate and guide their work.
- 7.1.1.2. The Chief Judge oversees administrative matters (correctness of paperwork, recording of penalties, etc.) but should be provided with a small group of special assistants who will perform at least the following tasks under his supervision:
- a) calling the manoeuvres and recording the notes of the Chief Judge, to whatever extent he requires;
 - b) processing and expediting the flow of paperwork;
 - c) receiving and recording the calls of the Line Judges;
 - d) handling all other radio communications. One of his assistants should assist in monitoring the zero marks and penalties awarded by the Judges after each flight.
- 7.1.1.3. It is essential that the Chief Judge follows each flight, with emphasis on recording hard zeroes, interruptions and height penalties. Such infringements and comments should be recorded, as an aide-memoire, on a score sheet which should be retained for reference prior to the judges scoresheets being submitted to the workstation. The official recording of penalties will be on the appropriate section of the score sheet reserved for the use of the Chief Judge and entered prior to submission to the scoring system.
- 7.1.1.4. The Chief Judge must hold seminars with the Judges, at least one of which will be with Team Managers or other team representatives present (CIVA 4.1.6.1). He should give guidance to the Judges as to the current Judging Criteria and rules for judging, on which he should conduct 'question and answer' sessions with the aid of the President of the Judging Sub-Committee.
- 7.1.1.5. The Chief Judge will hold other routine evaluation meetings with the Judges during the contest (CIVA 4.1.6.2), and before it begins he must hold practice sessions on the judging line during the contestants' training flights (see 6 below). He should insure that the Code of Practice is understood and operates smoothly, and establish a good working relationship between teams of Judges and Assistants, Timekeepers, and other helpers.
- 7.1.1.6. The Chief Judge is responsible for ensuring that there is enough time between flights for the judging to be unhurried: he should control (by radio) the flow from one contestant to the next.
- 7.1.1.7. At the end of each flight, the Chief Judge should ascertain whether any of the Judges has recorded a Hard Zero (HZ) mark, height penalty, interruption penalty or insertion penalty. This will be done by perusal of the score sheets collected from the judges, prior to entry into the scoring system.



- 7.1.1.8. In the event of a difference of opinion between the Judges concerning a Hard Zero (HZ) mark, height penalty or interruption penalty, the Chief Judge may, at his own discretion, either call a judging conference as soon as possible or follow CIVA Regulation **Error! Reference source not found.** at his workstation without further reference to the judges. The official video shall be available to assist in such discussion when it concerns a matter of fact, for example the direction of a rolling turn or the omission of a figure or manoeuvre. If the discussion concerns a matter of perception, such as the extent of an error off heading or whether a figure was flicked or not, then the video shall not be used. Instead the majority view shall be determined by the grades given by the judges in real time. The video should also be used to determine whether the HMD signal was received before or after the completion of a figure and thus whether a low penalty is justified in accordance with paragraphs 5.2.1.6 and 10.4.1.1.
- 7.1.1.9. In case of a vote among the Judges on the question of penalisation, all judges shall vote regardless of nationality, see also paragraph 5.1.1.3.

7.2. Hard Zeroes

- 7.2.1.1. The awarding of Confirmed Hard Zero marks is determined by the Chief Judge, if necessary after a judging conference. When a Judge's vote is over-ruled, upward correction of a Hard Zero will be to a Fitted Value determined by the scoring software. When awarding a Hard Zero, judges are to write down the nature of the error and are not to give a 'reserve' mark.
- 7.2.1.2. The Recommended procedure for handling Hard Zeroes and penalties on the judging line can be broken down as follows:
- 7.2.2. Hard Zeroes Given By The Majority Of Judges.**
- 7.2.2.1. The score sheets go to the scanner unchanged, the Chief Judge having checked the Confirmed Hard Zero (CHZ) box on the score sheet, unless a conference to confirm the facts is demanded by any judge(s). The computer system changes the minority scores to HZ and determines the judges' HZI points for Section 8.8.4.
- 7.2.3. Hard Zeroes Given By 50% Or Less Of The Judges.**
- 7.2.3.1. The Chief Judge first determines by means of conferencing whether the Hard Zero is correct or not. If correct, the Chief Judge will check the "CHZ" box on the score sheet; if not he will leave it blank. The judges must not change their score sheets as a result of the discussion. The score sheets will then go to the scanner and the computer system will then change the incorrect grades and determine judges' HZI points for Section 8.8.4.
- 7.2.4. Hard Zeroes – Fact or Perception.**
- 7.2.4.1. The Chief Judge will examine the reasons given by the scoring judges for the award of a Hard Zero. If the scoring judge has made a mistake and quoted a reason which is actually a matter of perception (e.g. "No Flick"), the Chief Judge will instruct that the scoring judge change his grade to Soft Zero.
- 7.2.5. Hard Zero Index (HZI).**
- 7.2.5.1. The Hard Zero Index (HZI) will be calculated by the computer, based on the grades given by the judges and the status of the "CHZ" box.



7.3. Height and Interruption Penalties.

- 7.3.1.1. Each judge must record such infringements on their score sheet. Where there are no such infringements the words “No Penalties” or “NP” should be entered in the remarks box, thus giving a positive indication in either instance. The Chief Judge or his assistant will then enter the appropriate penalty based on the majority result. In the case of a 50/50 split the Chief Judge may call a conference or cast his vote as appropriate.
- 7.3.1.2. The awarding of penalties for infringements of upper and lower height limitations is decided by majority vote of the judges. In the case the required simple majority could not rise from a vote within the Board of Judges, the Chief Judge shall have the casting vote; a two-thirds majority being required for the penalty of disqualification (CIVA 4.2.4.3)
- 7.3.1.3. The Chief Judge, assisted by the timekeepers, determines whether a super-slow roll was within the time limits (CIVA 5.3.3.1 g). He will also award the penalties for improper wing rocking (CIVA 5.2.6).
- 7.3.1.4. Judges evaluation by flight programme will be conducted by the International Jury using the software programme approved by CIVA. The Chief Judge will receive a complete analysis of all Judges from the International Jury.

7.4. The Judges

- 7.4.1.1. It is required that all Judges use an experienced Judge's Assistant from their own team, together with a writer who may be supplied as a member of the Judge's team or, on request, by the organisers (subject to availability).
- 7.4.1.2. All Judges should obtain and study copies of all contestants' Free Programmes before flying of the programme is started.
- 7.4.1.3. A Judge may only reconsider his marks so long as his score sheet is still in his possession or if asked to do so at the request of the Chief Judge. Once entered into the scoring system, the scoring sheet comes under the jurisdiction of the International Jury. The judge himself must sign off any changes on the score sheet.
- 7.4.1.4. The preliminary flights by non-competing pilots (CIVA 4.1.8.4) will be marked exactly as if they were competitors; bearing in mind that the purpose of these flights is so that the first competing pilot who follows them shall not be penalised by receiving an unduly low 'anchor' mark.
- 7.4.1.5. Judges must record as many comments on the score sheets as possible, with particular reference to significant errors. They may make these comments in any language or form, provided that they are able to explain the comments if required.
- 7.4.1.6. A judge will not make improper communication to third parties by means of cell phone, radio, or other device whilst on the judging line or during breaks/lunches. Failure to adhere to this instruction may lead to expulsion from the judging line.



8. STATISTICAL METHOD FOR PROCESSING SCORES

8.1. The CIVA Fair Play System - Purpose

8.1.1.1. Calculation of grades and scores for an aerobatic competition Programme using a mathematical process to give equal importance to all judges, while replacing anomalous grades with statistically fitted values.

8.2. Overview

The rating of a pilot performance for a given flight is an amount of points arising from two separate sources:

8.2.1.1. An evaluation of the quality of flown figures and of a flight's positioning with a grade given by judges observing the flight, on a scale ranging from 0 to 10 in increments of 0.5. These grades are multiplied by difficulty coefficients for each figure and added to derive a score for the programme for each pilot.

8.2.1.2. Penalties arising from height or time infringements and/or interruptions of the program sequence and other disciplinary actions.

8.2.1.3. The scores from 8.2.1.1 are subject to random and systematic errors due to the inevitable lack of exactness of judging. The purpose of the Fair Play system is to reduce the effect of those errors to a minimum. The penalties from 8.2.1.2 are not subject to the same errors and are simply subtracted from the scores results 8.2.1.1 after they have been calculated as described below.

8.3. Pre-Processing

8.3.1. Dealing with Hard Zeros and Missed Figures

8.3.1.1. Prior to the scoring data being entered into the computer, the Chief Judge must ascertain the validity of Hard Zero grades. If a figure is determined to have been a Confirmed Hard Zero, this must be designated by the Chief Judge. The grades given to that figure by the grading judges must not be altered prior to being input into the computer.

8.3.1.2. For a figure determined not to be a Confirmed Hard Zero, any "HZ" grade given by a grading judge must remain unaltered prior to data entry into the scoring computer.

8.3.1.3. Figures that have been missed by a grading judge must be marked "AG". These missing grades will be replaced automatically by the Fair Play system.

8.3.2. Identifying Figure Grades for Analysis

8.3.2.1. Prior to the start of the Programme, the data input to the scoring computer will include the number of pilots, the number of figures (including positioning and, for gliders, harmony) each pilot will fly, the K-factors of each figure and the number of judges for the programme.

8.3.2.2. Each figure will be given a full identifying number in the format **kkkffpp** where:

- a) *kkk* is the K-factor, with leading zeroes if necessary, e.g. "037" if K-factor =37
- b) *ff* is the figure number, with leading zeroes if necessary, and



c) *pp* is the pilot number, with leading zeroes if necessary.

8.3.2.3. Note that the number *pp* allocated to a pilot must remain the same throughout a contest and should not be confused with the flight order number any pilot may be allocated for a particular programme.

8.3.3. Grouping Figure Grades for Analysis

8.3.3.1. Statistical manipulation must only be carried out on sets of data of reasonable size. Furthermore, such analysis is best conducted on sets of data that share similar source characteristics. To meet these requirements, the grading data from a programme must be combined into appropriate groups.

8.3.3.2. For the purpose of the Fair Play analysis, data will be arranged in groups in the following generalised format:

K-factor	Figure #	Pilot #	Judge 1	Judge 2	Judge j
Kkk_1	ff	pp	Grade _{1,1}				
Kkk_2	ff	pp					
Kkk_3	ff	pp					
...					
...					
kkk_n	ff	pp					Grade _{n,i}

8.3.3.3. In such a data set, the arrangement of rows will be by ascending value of the full figure Identification Number *kkkffpp*. In compulsory programmes, Known and Unknown, all pilots fly the same figures and the number of rows per data group will normally be the same as the number of pilots. This means that each data group in a compulsory sequence will correspond to a figure of that sequence flown by all pilots, in the form:

K-factor	Figure #	Pilot #	Judge 1	Judge 2	Judge j
kkk	Figure 1	Pilot 1	Grade _{1,1}				
kkk	Figure 1	Pilot 2					
kkk	Figure 1	Pilot 3					
...					
...					
kkk	Figure 1	Pilot p					Grade _{p,j}

8.3.3.4. Exceptionally, if the number of pilots is less than 11 (see **Error! Reference source not found.**), the target number of rows for each group (NrmGrp) will be as follows:

Number of Pilots	2	3	4	5	6	7	8	9	10
Group Size	12	12	12	15	12	14	16	18	20

8.3.3.5. In Free Programmes, where pilots fly different figures and/or numbers of figures, additional information is required so that the figures included in each data group are reasonably similar in type and complexity. Therefore each figure in a Free Programme (including Positioning and Harmony grades) will additionally be allocated to a Super-Family. Super-Families are defined as follows.



Super-Family Numbers (FF)	Unlimited Power	Adv & Y52 Power	Gliders
Harmony			00
Positioning	01	01	01
Aresti family 2	02	02	02
Figures containing spins	Spins ignored	03	03
Figures without spins but with flicks	Flicks ignored	04	04
Aresti family 5	05	05	05
Aresti family 6	06	06	06
Aresti families 1, 7 and 8	07	07	07

Notes: In Unlimited Power, Spins and Flicks are ignored and the Super-Family depends only on the Aresti Family of the underlying figure. If either Super-Family 05 or 06 contains less figures than the minimum of 11 data points, these two Super-Families will be combined.

8.3.3.6. Hence a Full Free Figure Identification Number will be of the form FFkkkffpp.

8.3.3.7. Free Programmes.

- a) In the Positioning and Harmony Super-Families, the group size will equal the number of pilots, i.e. each will contain the complete Super-Family. If the number of pilots (N_p) whose flights have been judged is < 11 , however, (see 1.2.3.3) then these Super-Families will be combined into a group containing them both.
- b) In other Super-Families, comprising aerobatic figures, the data groups will be formed from within each Super-Family, unless N_p is less than 11. The target number of rows for each group (N_{rmGrp}) will be the number of pilots whose flights have been judged, while the minimum group size ($MinGrp$) will remain 11 rows. When $N_p < 11$, then N_{rmGrp} will be as tabulated in 8.3.3.4, and a group may contain figures from more than one Super-Family. When a Super-Family contains more figures than the number of pilots, it may thus be split into two or more groups.
 - i) The boundary between adjacent groups within a single Super-Family will be made preferably at the change of K-factor nearest the target size within the range 'target row to target plus minimum rows', or if this is not successful nearest the target size but between the target row and the minimum group size. If no change of K-factor is available the group boundary will be set at the target row.
 - ii) For example, suppose that a Free Programme has 40 pilots and that Super-Family 07 contains 250 figures. This data will be divided into a number of groups, each of which will contain approximately 40 rows. The final group will contain at least 11 rows.

8.3.3.8. No analysis should be started until all groups contain at least 5 rows of numerical data. Results calculated by FPS are liable to change until all data have been entered. Once the data have been compiled into groups, the analysis will proceed as follows.

8.3.4. Confirmation of Hard Zero

8.3.4.1. The first stage of processing is to set to "HZ" all numerical grades given to a figure subsequently deemed to be a Confirmed Hard Zero by the Chief Judge. Any grade thus reduced to "HZ" must result in an increment to the particular judge's record for determining the HZ anomaly count of the Judging Performance Analysis.



8.3.4.2. Once Confirmed Hard Zeros have been implemented, each pilot's score sheet should be printed and made available for inspection along with the judges grading sheets.

8.3.5. Treatment of Other "HZ" or of "AG" Grades

8.3.5.1. If a figure is not deemed to be a Confirmed Hard Zero, any "HZ" or "AG" grades given for that figure must be treated as missing data points. Such grades will therefore be excluded from the calculation of means or standard deviations until such time as they are replaced later in the process. For each "HZ" grade that is not confirmed, an increment will be made to the judge's HZ anomaly count.

8.3.6. Treatment of Soft Zero Grades

8.3.6.1. Soft Zero grades are not subject to the same confirmation process as Hard Zeros. They are generally treated as valid numerical grades in the same way as non-zero grades. However, Soft Zero grades should not influence the normalisation of non-zero grades that is described below.

8.4. Definitions

8.4.1. The Basic Data Values

8.4.1.1. Define the Raw Grades, for a given sequence, as:
 $S(ff, pp, j)$

This is the Grade awarded by Judge j to Pilot pp flying Figure ff .

8.4.1.2. These Grades are then divided into semi-homogeneous Groups as defined above, and are now defined as:

$R_g(fp, j)$

This is the Grade awarded by Judge j to (Pilot p flying Figure f) in Group g , and is represented physically by a rectangular array of numbers where fp is the row index and j is the column index.

8.4.1.3. There should also be a count indicator of values 0 and 1 to indicate 0 for any SZ, HZ or A values. These are designated: $N_g(fp, j)$

8.4.1.4. Counts

a) Pilot Count = No. Judges who score this pilot/figure combination

$$C_g(fp, *) = \sum_j \{N_g(fp, j)\} \quad (1)$$

b) Judge Count = No. Pilot/figures scored by this judge

$$C_g(*, j) = \sum_{fp} \{N_g(fp, j)\} \quad (2)$$

c) Overall Count = Total number of Scores

$$C_g(*, *) = \sum_{fp, j} \{N_g(fp, j)\} \quad (3)$$

8.4.1.5. Mean Values

a) Pilot Mean

$$mR_g(fp, *) = \sum_j \{R_g(fp, j)\} / C_g(fp, *) \quad (4)$$

b) Judge Mean

$$mR_g(*, j) = \sum_{fp} \{R_g(fp, j)\} / C_g(*, j) \quad (5)$$



- c) Overall Mean

$$mR_g(*, *) = \sum_{fp,j} \{R_g(fp, j)\} / C_g(*, *) \quad (6)$$

8.4.1.6. Standard Deviations

- a) Judge Standard Deviation

$$sdR_g(*, j) = \sqrt{([\sum_{fp} \{R_g(fp, j)\}^2 - C_g(*, j) \{mR_g(*, j)\}^2] / [C_g(*, j) - 1])} \quad (7)$$

- b) Average Judge Standard Deviation

$$sdR_g(*,) = \sum_j \{sdR_g(*, j)\} / J \quad (8)$$

8.5. Group Processes

8.5.1. Normalisation of a Data Group

- a) The first stage of the analysis is to Normalise the non-zero grades in the data group to give each judge's column of grades the same standard deviation. This will give equal importance to each judge's opinion. In the normalisation formula:
- b) Norm1_g(fp,j) is the Normalised grade to replace the Raw grade
sdR_g(* ,j) is the standard deviation for a judge's Raw grades in this group
sdR_g(* , *) is the standard deviation for all the Raw grades in this group from all judges and,

$$\text{Norm1}_g(fp,j) = mR_g(*, *) + [R_g(fp,j) - mR_g(*, j)] * sdR_g(*,) / sdR_g(*, j) \quad (9)$$

- 8.5.1.2. If the result of formula (7) or (8) is zero, then formula (9) cannot be applied and the grades for this judge, or this group, should be set to the overall mean for this group. If the result of formula (9) is less than zero, then it should be set at zero.

- 8.5.1.3. Soft Zero (0.0) grades are excluded from this normalisation process because, for each judge, these form part of a second mode of distribution of raw grades. After the non-zero grades are normalised, the Soft Zero grades are set to 0.0 so that they are included in the process of determining Fitted Values and figure anomalies. Hence:

$$\text{If } R_g(fp,j) = 0.0, \text{ Then Norm1}_g(fp,j) = 0.0 \quad (9a)$$

8.5.2. Derivation of Fitted Values

- 8.5.2.1. Within the data group, a Fitted Value for a figure grade for a pilot is the grade that you would expect a particular judge to give a particular pilot/figure combination, based on an analysis of all the judges' grades for all the pilot/figure combinations in the group, including numerical zeroes (SZ) but excluding factual zeroes (HZ). In the Fitted Value formula:

- a) FV1_g(fp,j) is the Fitted Value derived from Norm1_g(fp,j)
mNorm1_g(* ,j) is the mean of the Normalised numerical grades in the group for that judge
mNorm1_g(fp, *) is the mean of the Normalised numerical grades in the group for that pilot/figure
mNorm1_g(* , *) is the mean of all the Normalised numerical grades for that group for all judges and,

$$FV1_g(fp,j) = mNorm1_g(*, j) + mNorm1_g(fp, *) - mNorm1_g(*, *) \quad (10)$$

8.5.3. Assessment of Anomalous Grades

The normalised grades in each group must be tested for anomalies caused by judging error or partiality.



8.5.3.1. The Uncertainty of Any Individual Data Point

- a) A data point (grade) will be considered anomalous if its uncertainty exceeds a given threshold value. This uncertainty is derived by a two-way analysis of variance and starts with the calculation of the Residual for each data point. In the Residual formula:
- b) $Res1_g(fp,j)$ is the Residual value for each data point in the group after the first normalisation, and,

$$Res1_g(fp,j) = Norm1_g(fp,j) - FV1_g(fp,j) \quad (11)$$

- c) $RSS1_g$ is the Residual Sum of Squares for the data group after normalisation and,

$$RSS1_g = \sum_{fp,j} \{Res1_g(fp,j)\}^2 \quad (12)$$

8.5.3.2. The Degrees of Freedom of the data group is determined by:

- a) D_g is the value of the Degrees of Freedom of the data group
 FP_g is the number of pilot/figure rows in the group
 J_g is the number of judges in the programme (columns in the data group)
 Nm_g is the number of missing values (HZ or A) in the group, and

$$D_g = \{[FP_g - 1] * [J_g - 1]\} - Nm_g \quad (13)$$

8.5.3.3. The Residual Standard Deviation of the data group, $RSD1_g$, is determined by:

$$RSD1_g = \sqrt{RSS1_g / D_g} \quad (14)$$

8.5.3.4. Finally, the uncertainty of each individual data point, $U1_g(fp,j)$ is calculated:

$$U1_g(fp,j) = ABS[Res1_g(fp,j)] / RSD1_g \quad (15)$$

8.5.4. Treatment of Anomalous Grades

8.5.4.1. If the uncertainty of an individual grade, $U1_g(fp,j)$, exceeds 2.24 it has an uncertainty of approximately 97.5%. This degree of anomaly, or more, is to be expected in the case of a small number of soft zeroes for a figure which generally attracts a majority of high grades. Similarly, such an anomaly might occur if a single judge missed a large pilot error that led all other judges to award a very low grade. Anomalies such as this should be treated as though they were missing values. This treatment will give the benefit of the doubt to the pilot in situations where it is possible that a very significant judging error has been made.

8.5.4.2. The raw grade for any data point showing such an anomaly should be set to “Missing” in the original Raw Data $Rg(fp, j)$ – call it $R2g(fp, j)$. The judge concerned should have an increment made to Low or High Score anomaly count in the Judging Performance Analysis, as appropriate, for each grade replaced.

8.5.4.3. When making judgements based on the perception of the quality of flick rolls or spins, the panel of judges might produce a series of grades in which the distribution is bi-modal rather than Gaussian. For example, a set of grades might possibly include a number of soft zeroes and a number of high grades. In extremely rare cases, this difference of opinion may be so great that the majority of raw grades might be considered anomalous by this analysis. In this situation it is not fair to assume that the remaining grades are truly representative of the pilot’s performance of the figure concerned.



8.5.4.4. Therefore, if the number of missing values that would be carried forward to the second normalisation exceeds 60% of the number of judges, all grades for this figure by this pilot should be replaced by the FV1 value derived at Formula 10.

8.5.5. Second Normalisation of the Group

8.5.5.1. If anomalies have been removed from the raw grades, the data set will have more missing values. It would therefore be necessary to normalise the data group for a second time. Again, Soft Zero (0.0) grades must be excluded from the Normalisation and these grades must remain 0.0. Using only the remaining non-zero grades new values must be determined for $mNorm_g(*,j)$, $mN_g(fp, *)$, $mN_g(*, *)$ and thus $FV_g(fp,j)$.

a) Hence,

$$Norm2_g(fp,j) = mR2_g(*,*) + [R2_g(fp,j) - mR2_g(*,j)] * sdR2_g(*,) / sdR2_g(*,j) \quad (16)$$

b) and,

$$FV2_g(fp,j) = mNorm2_g(*,j) + mNorm2_g(fp,*) - mNorm2_g(*, *) \quad (17)$$

8.5.5.2. These new fitted values will have been determined free from the influence of any anomalous grades and are thus robust and give the benefit of any doubt to the pilot in the case of minority soft zeroes for an otherwise highly-graded figure.

8.5.6. Replacement of Missing Grades

8.5.6.1. These $FV2_g(fp,j)$ values are then used to replace the HZ, A and 'Missing' anomalous grades carried forward from the preceding analysis.

8.5.6.2. The judge concerned should have an increment made to his Low Score or High Score anomaly count in the Judging Performance Analysis, as appropriate, for each anomalous grade replaced, as well as to the HZ anomaly count for any HZ replaced.

8.5.6.3. After these replacements, the second normalised grades will be the final processed grades for each data group.

8.5.7. Assembly of Processed Grades by Pilot

8.5.7.1. After processing in the separate data groups, the final processed grades must be combined into a single matrix and this table sorted by ascending value of the Pilot identification number and then the figure number. These grades are then multiplied by the respective K-factor for each figure and totalled to give:

a) $SR(p,f,j)$ an overall score for each pilot on each figure from each judge

8.5.7.2. These can then give

a) $SR(p,f,*)$ an overall score for each pilot for each figure over all judges, where:

$$SR(p,f,*) = \sum_j SR(p,f,j) \quad (18)$$

b) $SR(p,*,j)$ an overall score for each pilot for each judge over all figures, where:

$$SR(p,*,j) = \sum_f SR(p,f,j) \quad (19)$$

c) $SR(p,*,*)$ an overall score for each pilot, where:

$$SR(p,*,*) = \sum_{f,j} SR(p,f,j) \quad (20)$$



8.5.7.3. These data should be printed and passed to each pilot at the earliest possible stage, so that the changes made during the processing stage can be understood.

8.6. Sequence Processes

8.6.1. Normalisation of Sequence Scores

8.6.1.1. It is now necessary to repeat the normalisation process at the sequence stage, once again to ensure that the opinion of each judge is given the same importance.

8.6.1.2. The sequence score data, $SR(p,j)$, can be set out in a matrix form as shown here.

Pilot #	Judge 1	Judge 2	Judge 3	Judge j
Pilot 1	$SR(1,1)$	$SR(1,2)$
Pilot 2	$SR(2,1)$
Pilot 3
...
...
Pilot p	$SR(p,j)$

8.6.1.3. From this table:

- a) $mSR(*,j)$ is the mean of all the scores given by Judge j.
 $sdSR(*,j)$ is the standard deviation of all the scores given by Judge j.
 $sdSR(*,*)$ is the average standard deviation of all the scores given to all the pilots by all the judges, and

$$\text{NormS}(p,j) = mSR(*,j) + [SR(p,j) - mSR(*,j)] * sdSR(*,*) / sdSR(*,j) \quad (21)$$

8.6.2. Derivation of Sequence Fitted Values

8.6.2.1. Next sequence fitted values are derived from the normalised scores to enable calculation of standardised residuals at the sequence level. In this derivation:

- a) $mNormS(*,j)$ is the mean of all the normalised scores given by Judge j.
 $mNormS(p,*)$ is the mean of all the normalised scores given to Pilot p.
 $mNormS(*,*)$ is the mean of all normalised scores given by all judges to all pilots, and

$$FVS(p,j) = mNormS(*,j) + mNormS(p,*) - mNormS(*,*) \quad (22)$$

8.6.3. Assessment of Sequence Anomalies

8.6.3.1. Despite the replacement of anomalous figures at the earlier stage of the process, it might be possible for slight, consistent favouritism or subconscious bias to influence unduly a Judge's overall score for a pilot. Such a score might be high or low and should be replaced if its degree of uncertainty reaches approximately 90%.

8.6.3.2. Therefore the analysis must next derive the residuals for the sequence scores:

$$ResS(p,j) = NormS(p,j) - FVS(p,j), \text{ and} \quad (23)$$

$$RSS_s = \sum_{p,j} \{ResS(p,j)\}^2 \quad (24)$$



8.6.3.3. The number of degrees of freedom for the sequence data set is calculated where:

- a) D_s is the value of the Degrees of Freedom of the sequence data
 P_s is the number of Pilots in the sequence
 J_s is the number of judges in the sequence
 Nm_s is the number of missing values (confirmed HZ for all figures by a pilot), and

$$D_s = \{[P_s - 1] * [J_s - 1]\} - Nm_s \quad (25)$$

8.6.3.4. The Residual Standard Deviation for the sequence is given by:

$$RSD_s = \sqrt{RSS_s / D_s} \quad (26)$$

8.6.3.5. The uncertainty of each sequence score is given by:

$$US_s(p,j) = ABS[ResS(p,j)] / RSD_s \quad (27)$$

8.6.3.6. If this uncertainty figure exceeds 1.65 (90%) it must be replaced by the fitted value FVS(p,j).

8.6.4. Interim Final Sequence Score

8.6.4.1. The processed sequence score for each pilot will be the sum of the normalised sequence scores over judges, after replacement of anomalous values of NormS(p,j) by fitted values FVS(p,j).

$$PS(p) = \sum_j \{NormS(p,j) \text{ or } FVS(p,j)\} / N_j \quad (28)$$

8.6.4.2. Penalties awarded for whatever reason are subtracted from this processed score to give each pilot's final overall score for the sequence.

$$FS(p) = PS(p) - Pen(p) \quad (29)$$

8.6.5. Second FPS Iteration and Final Sequence Score

8.6.5.1. When flights are of a very low standard, it is unlikely that the judges will show the same consistency of grading as when flights are of a high standard. Therefore, such low standard flights can have undue influence over the way in which the FPS system treats other scores.

8.6.5.2. To prevent such undue influence, the following procedure will be followed if the total number of competing pilots exceeds 30:

- a) Determine the values of PS(p) as a percentage of the maximum possible score for the sequence.
- b) If this value is less than 60% for a known sequence (Programmes Q, 1 and 4), or less than 50% for an unknown sequence, temporarily remove these flights raw data from the whole data set and re-apply the FPS process in its entirety. This will generate more reliable results for the retained pilots.
- c) Publish the final ranked order, based on FS(p) from the first FPS iteration for the excluded, low-scoring pilots, and based on FS(p) from the second FPS iteration for the retained, higher scoring pilots.

8.7. Process Summary

8.7.1. The process carries out the following analytical steps:

8.7.1.1. Sets confirmed Hard Zeros to HZ for all judges

8.7.1.2. Treats unconfirmed HZ and A grades as "Missing" at this stage.



8.7.1.3. Arranges figure grades into data groups for further analysis.

8.7.1.4. Within each data group:

- a) Normalises the grades to give equal importance to each judge.
- b) Derives fitted values for each judge for each figure.
- c) Determines if any normalised grades are more than 95% uncertain and disregards them by setting them to “Missing”.
- d) Derives revised normalised grades and fitted values taking account of the new missing data.
- e) Replaces all the missing grades with revised fitted values.

8.7.1.5. At the sequence level:

- a) Normalises the scores to give equal importance to each judge.
- b) Derives fitted values for each judge for each pilot.
- c) Determines if any scores are more than 90% uncertain and replaces them with fitted values.

8.7.1.6. In the Second Iteration:

- a) Repeats the FPS process excluding certain low-scoring flights.
- b) Recombines all results into a final ranking order.

8.8. Judging Performance Analysis

The Fair Play System generates judging analysis data from the raw and FPS-processed scores. A Ranking Index is derived and judging errors totalled in a number of different categories. This data is gathered by the FPS and made available to the International Jury after each sequence and may, at the Jury’s discretion, be passed on the Chief Delegates of each national team at the completion of each Programme, or at the end of the contest.

8.8.1. Ranking Index (RI)

8.8.1.1. The Ranking Index measures how closely an individual judge’s pilot ranking for a programme conforms to the overall ranking based on all judges’ assessments. It is derived by comparing the ranking each judge would have provided for each pilot if no other judges were present (*Jrank*) with the overall ranking calculated from the combined judging panel after all anomalies have been resolved and prior to any penalties being included (*Prank*). In the event that *Jrank* and *Prank* differ, this difference is weighted by an amount proportional to the differences in the underlying sequence scores that lead to this difference. A ranking error is penalised more heavily when it involves a larger difference in scores than when only minor differences in scores are the cause.

8.8.1.2. To derive the “raw” Judge rankings (*Jrank*), all HZ and SZ grades are set to numerical zero (0.0) and any “AG” grade is assumed missing. This array of data is then normalised, and Fitted Values determined using normal FPS techniques. “AG” grades only are replaced with



FV and then a pilot total score is calculated by multiplying each normalised figure mark by the relevant K Factor.

8.8.1.3. After the full FPS process is complete, a full panel score (Pscore) and ranking (Prank) is determined for each pilot prior to the application of any penalties.

8.8.1.4. To derive the “Raw” Judge scores (*Jscore*), a final normalisation is conducted to rescale each judge’s all-pilot average “raw” scores and all-pilot average standard deviation of “raw” scores (as calculated in 8.8.1.2) to be the same as the all-pilot average and standard deviation of the full panel score (calculated in 8.8.1.3).

8.8.1.5. An index is now derived from these data for each judge. This takes account of differences in ranks and differences in total scores. Thus:

$$RI = \left\{ \sum_1^{Np} \frac{abs(Jrank - Prank) * abs(Jscore - Pscore)}{Jscore} \right\} * \frac{40}{Np}$$

8.8.1.6. Typically, a judge’s Ranking Index will be in the range 1 to 50, lower numbers indicating that a judge’s individual rankings are closer to the overall panel rankings. When there has been a second FPS iteration in accordance with rule 8.6.5, the RI is calculated using only data from the second iteration, i.e. pilots excluded from the second iteration are also excluded from the RI calculation.

8.8.2. Low and High Scoring Anomalies

8.8.2.1. A Low or High Scoring Anomaly is determined to have occurred each time a judge grades a figure significantly lower or higher than the consensus view of the judges.

8.8.2.2. For each figure, examine the normalised scores. If a judge’s score for the figure has been determined ‘Low’ or ‘High’ at the approved confidence level, then add one to that judge’s aggregate of errors under the appropriate heading.

8.8.3. Discrimination

8.8.3.1. Judges show differing degrees of “Discrimination” in that they score over wider or narrower ranges of raw grades. The FPS will keep track of these raw grades for subsequent publication and analysis in the form of histograms and banded totals.

8.8.4. Hard Zero Anomalies

8.8.4.1. The occurrence of Hard Zeros is determined by majority voting or by video conference. The scoring system determines the application of the Index from the “CHZ” box on the score sheets.

8.8.4.2. In the event that an individual judge fails to identify a confirmed Hard Zero, then add one to that judge’s aggregate of errors under this heading. Similarly, if a judge gives a grade of HZ when no such error occurred, add one to the aggregate of errors under this heading.

8.8.5. Sequence Score Anomalies

8.8.5.1. A Sequence Anomaly occurs whenever a judge grades a whole sequence significantly higher or lower than the consensus view of the judges.

8.8.5.2. For each pilot, examine the normalised sequence scores. If a judge’s score for the sequence has been determined ‘High’ or ‘Low’ at the approved confidence level, then add one to that judge’s aggregate of errors under this heading.



Deliberately Blank



9. LIST OF FIGURES FOR PROGRAMMES 2, 4, 5 AND 6

NOTE: Unlinked and opposite rolls are not permitted.

9.1. Family 1.1 To 1.7

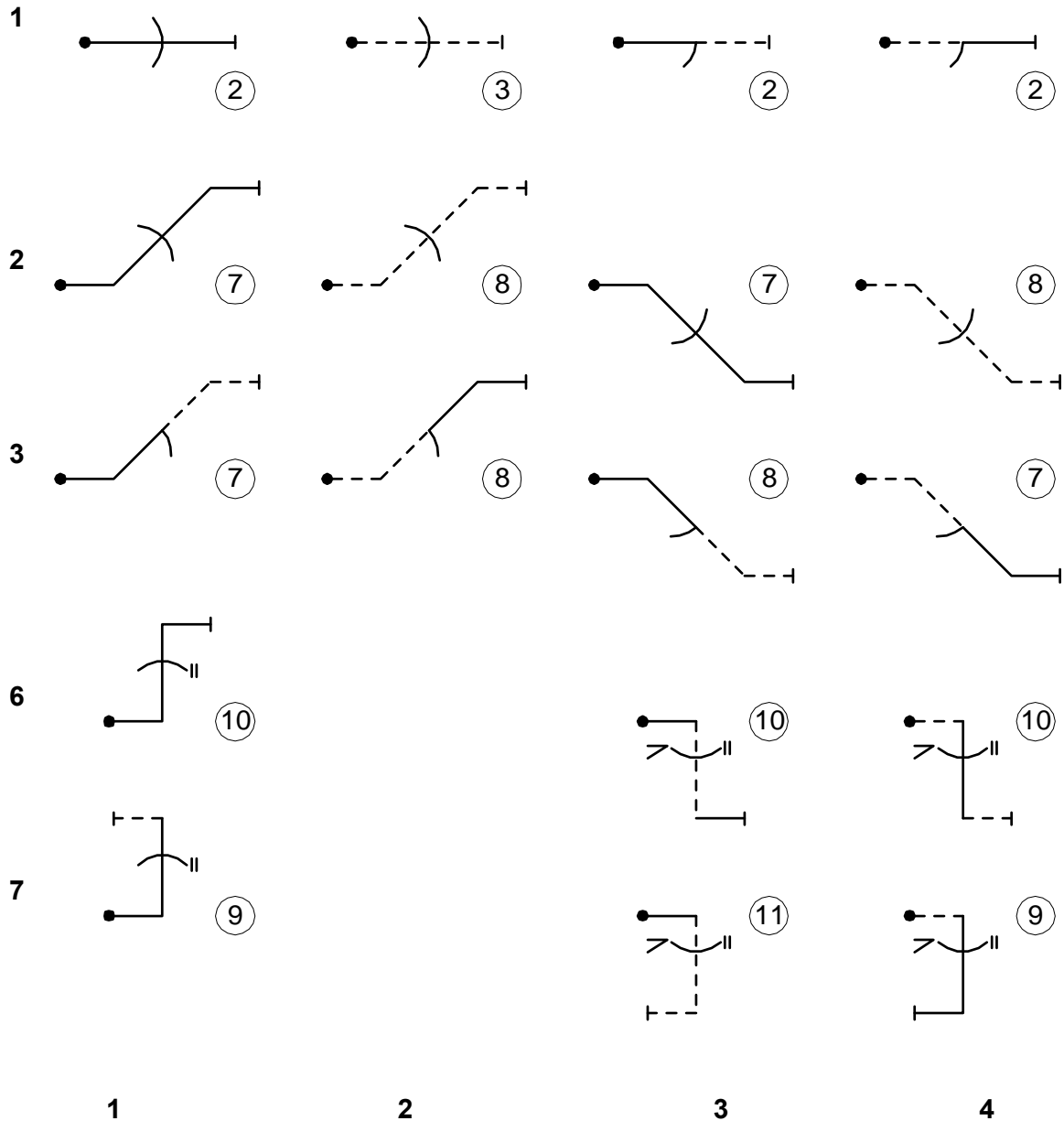



9.2. Family 1.12 To 1.15

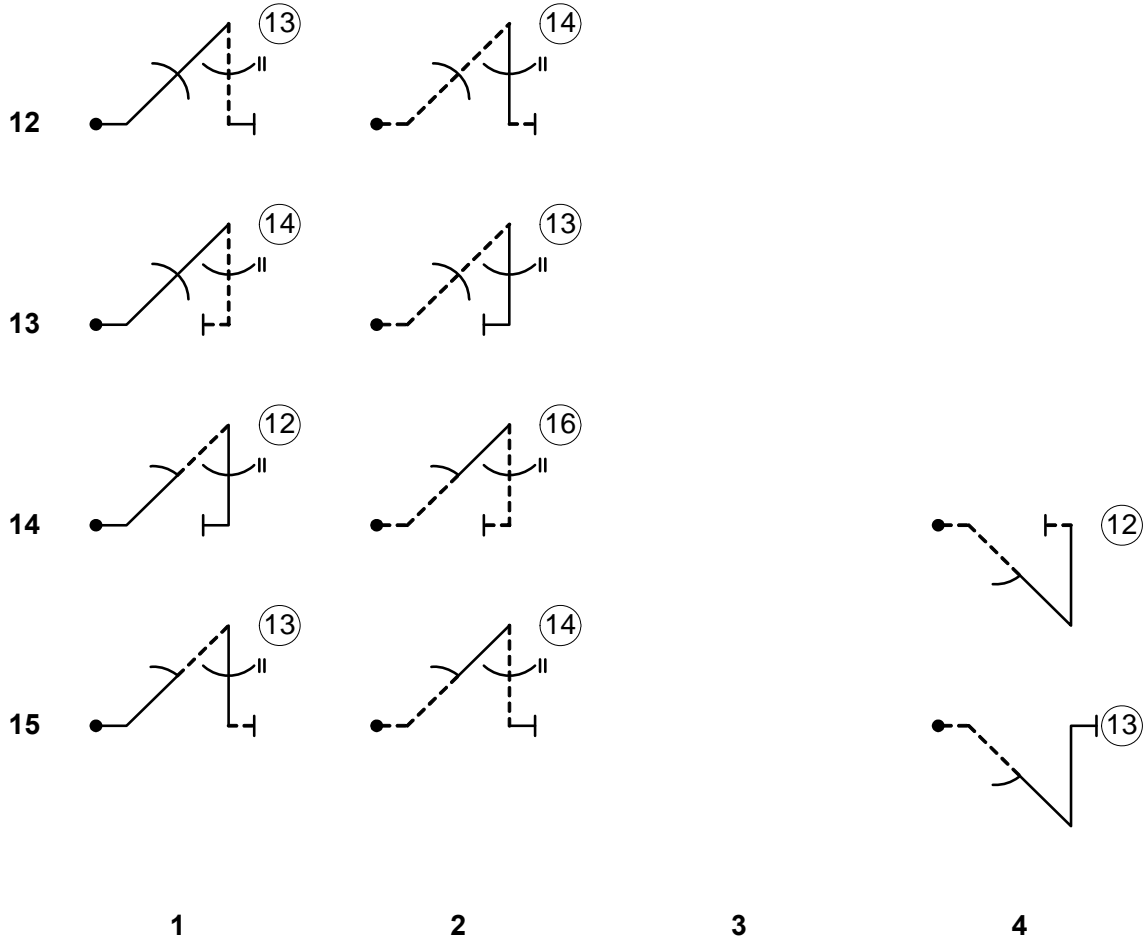

9.2.1.1. No vertical rolls are permitted in figures of column 4.



9.3. Family 2.1 To 2.19

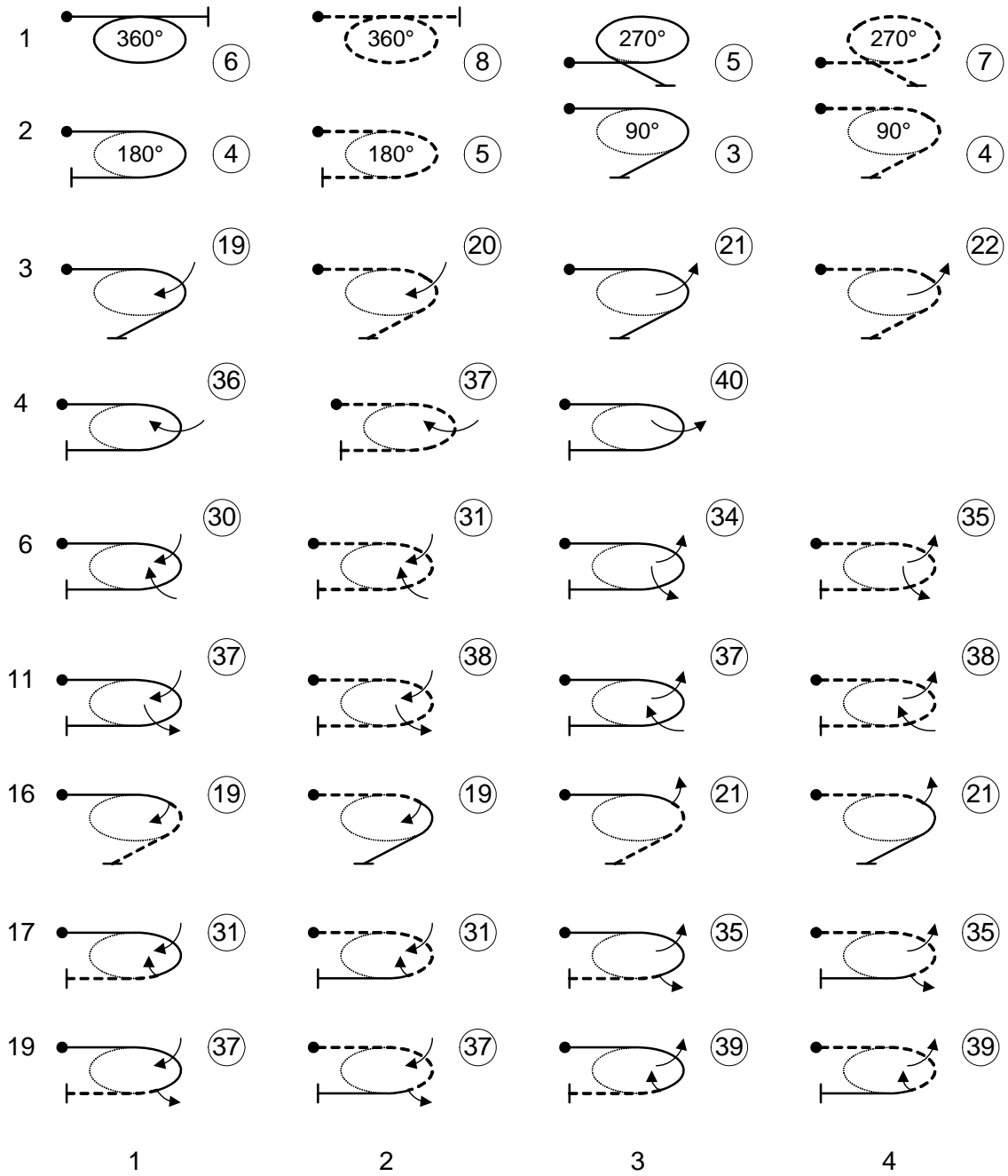

9.4. Family 5.1 STALL TURNS

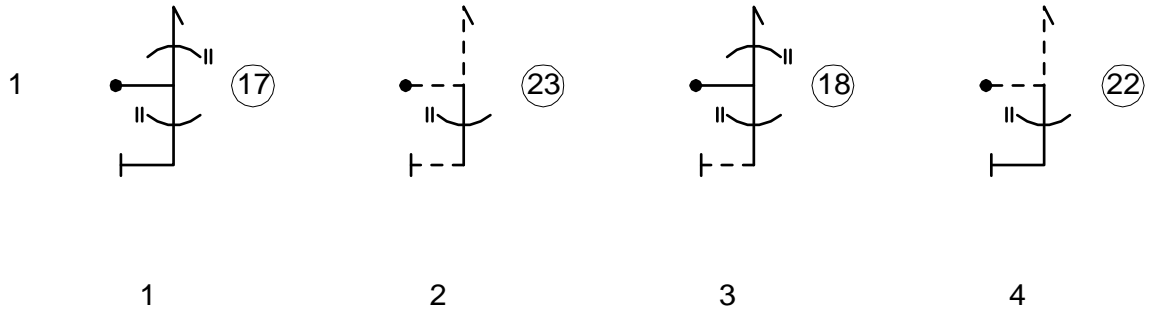

9.4.1.1. Rolling elements may only be added where indicated.

9.5. Family 6.1 To 6.2 Tail Slides

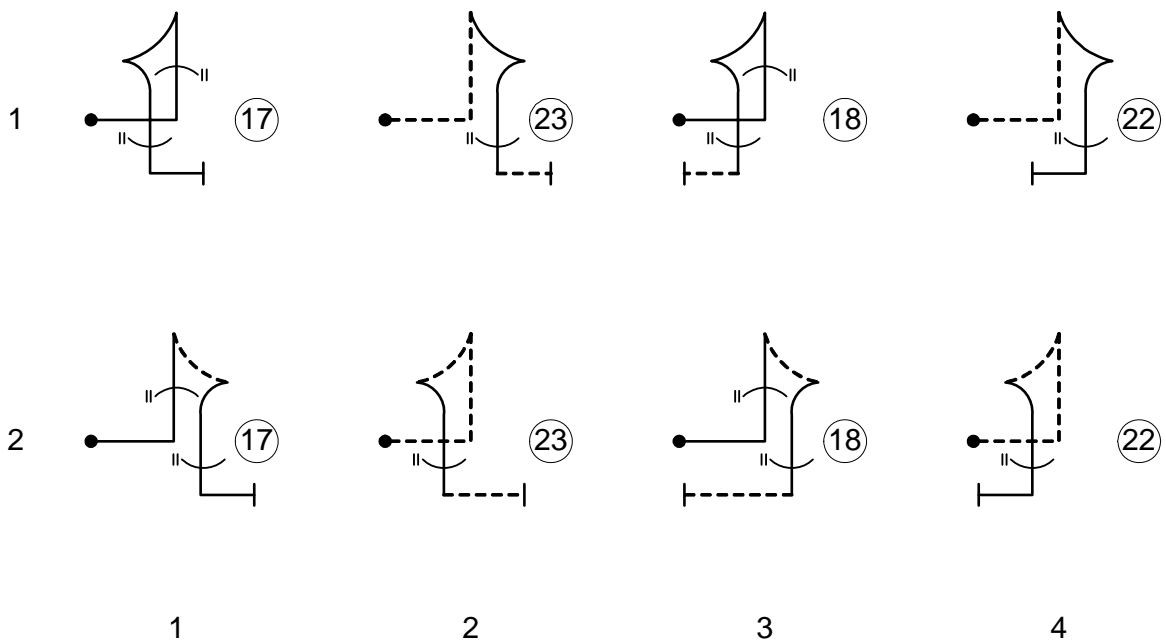

9.5.1.1. Rolling elements may only be added where indicated.

9.6. Family 7.1 To 7.6

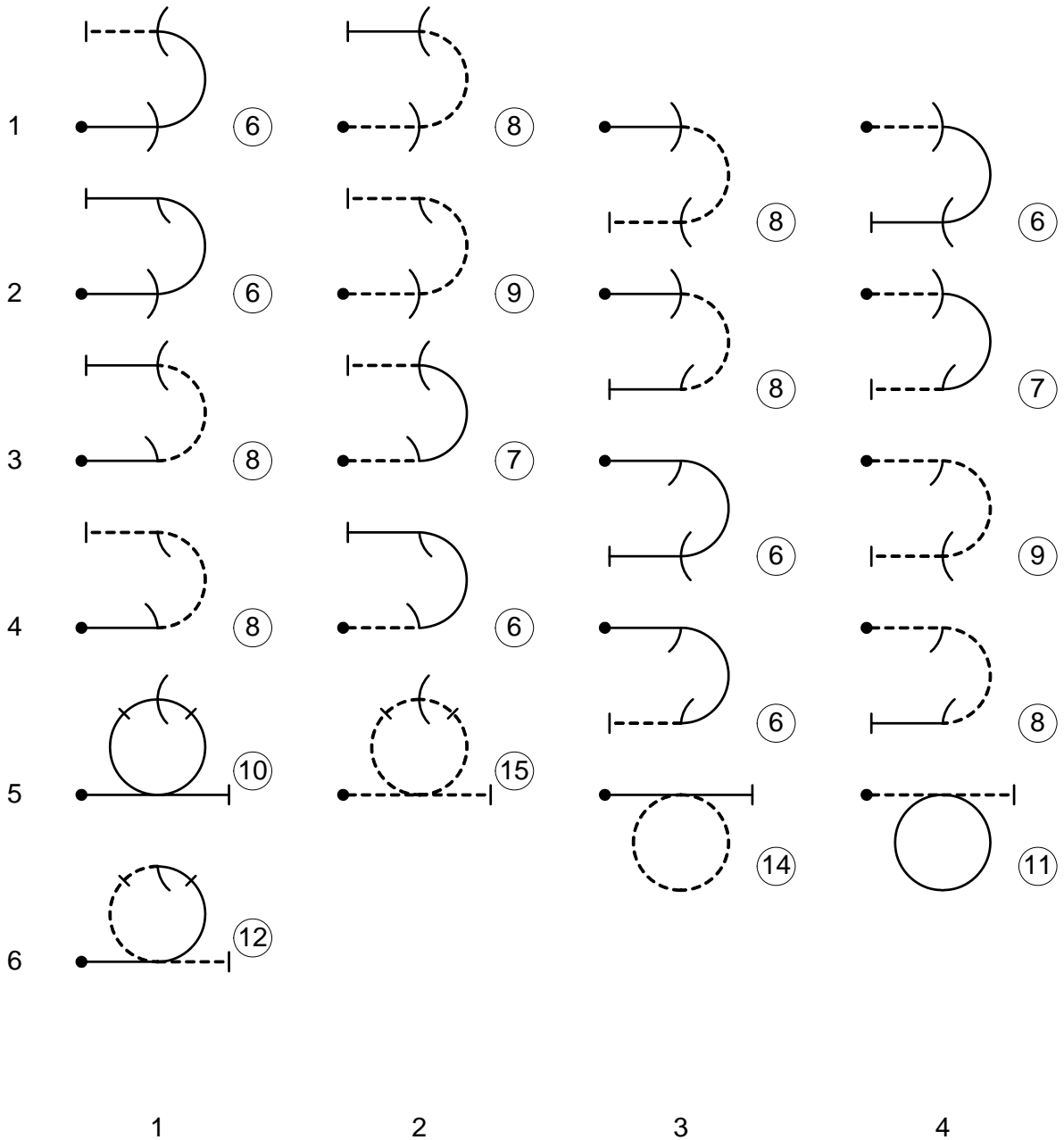

9.6.1.1. Flick rolls are not permitted on the horizontal entry lines of figures in columns 1 and 2, nor on the horizontal exit lines of figures in columns 3 and 4, of 7.1 to 7.4.

9.6.1.2. No rolls are permitted on figures 7.5.3 and 7.5.4.

9.6.1.3. No superslow rolls are permitted in the top of figures 7.5.1, 7.5.2 and 7.6.1.

9.6.1.4. No hesitation rolls are permitted in the top of figure 7.5.2.

9.7. Family 7.19 TO 7.26

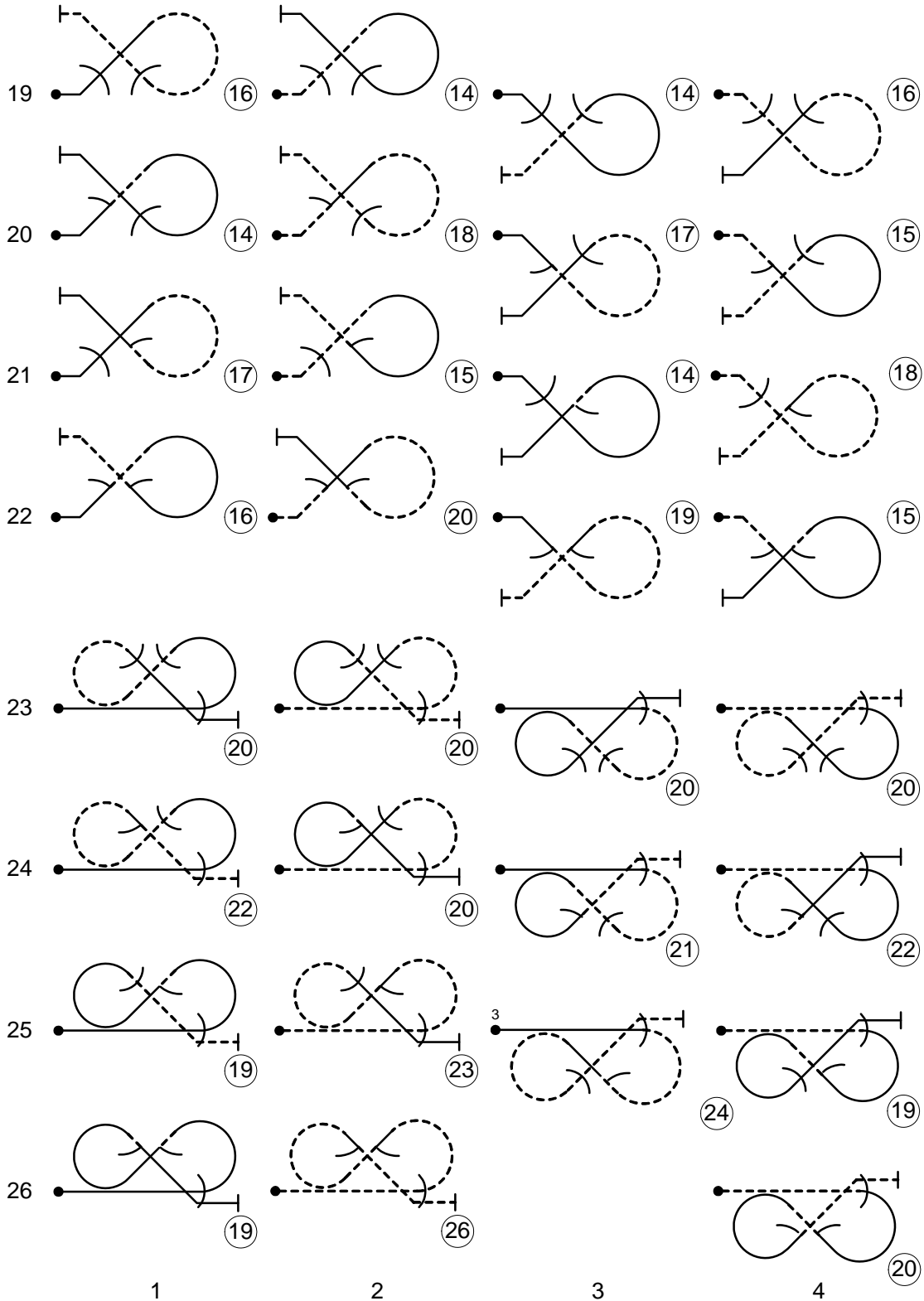

9.7.1.1. At the sign  only half rolls are permitted.

9.7.1.2. Flick rolls are not permitted on the horizontal entry lines of figures in columns 1 and 2, of 7.23 to 7.26.

9.8. Family 7.27 To 7.34

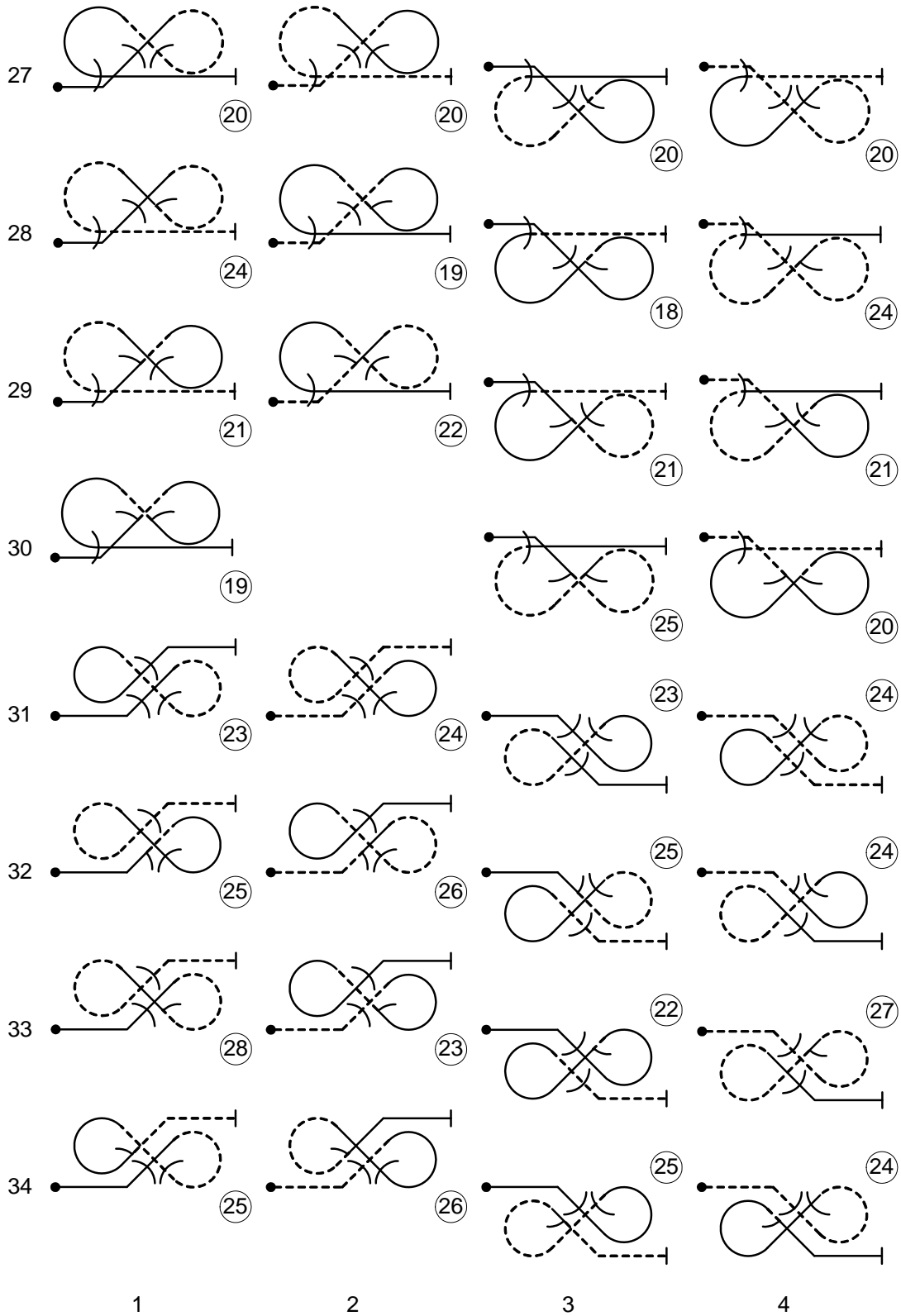

9.8.1.1. At the sign  only half rolls are permitted.

9.8.1.2. Flick rolls are not permitted on the horizontal exit lines of figures in columns 1 and 2, of 7.27 to 7.30.



9.9. Family 7.37

35

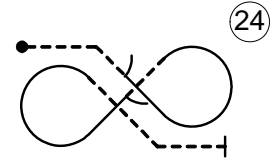

36

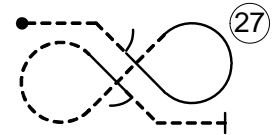
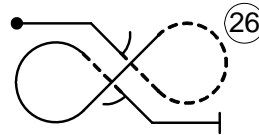

37

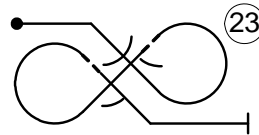

38

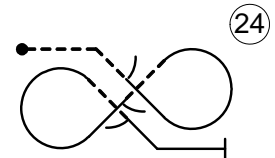

1

2

3

4

9.9.1.1. At the sign \curvearrowright only half rolls are permitted.

9.10. Family 8.1 To 8.4

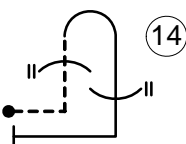
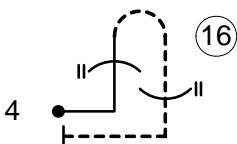
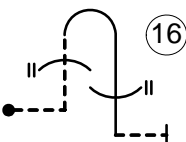
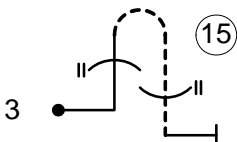
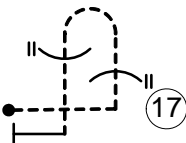
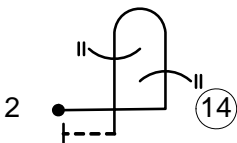
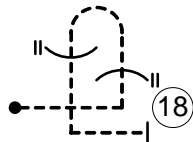
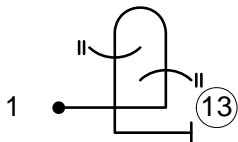

1

2

3

4

9.11. Family 8.13 To 8.18

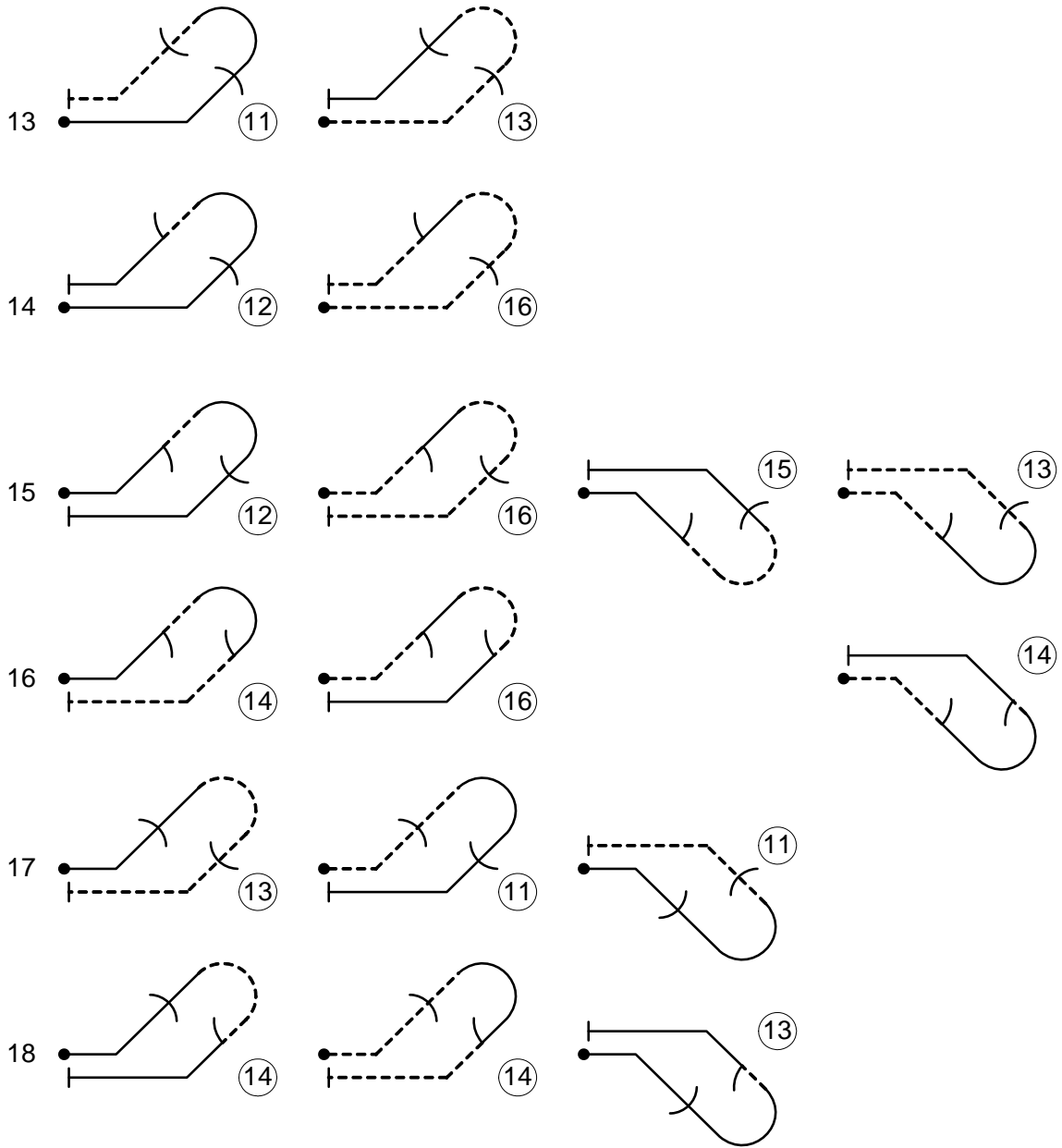

1

2

3

4

9.11.1.1.No flick rolls are permitted on the down lines of figures 8.15.2, 8.16.2, 8.17.1 and 8.18.1.

9.12. Family 8.31 To 8.40

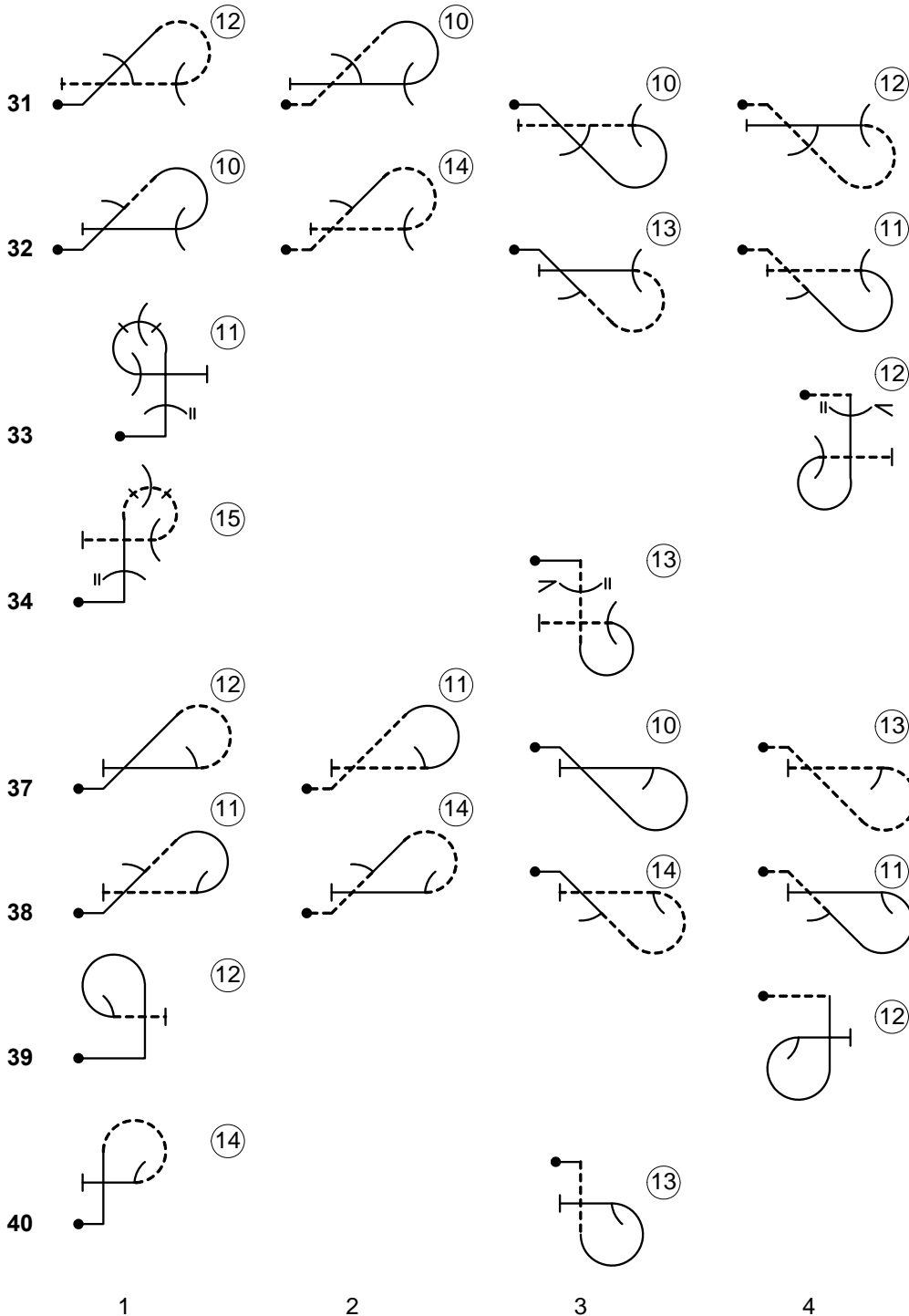

9.12.1.1. Flick rolls are not permitted on the horizontal exit lines of figures in columns 1 and 2 on this page.

9.12.1.2. No superslow rolls are permitted in the top of figures 8.33.1 or 8.34.1.

9.12.1.3. No rolls are permitted on top of figures 8.33.1 or 8.44.1 after a roll on the up line.

9.13. Family 8.41 To 8.46

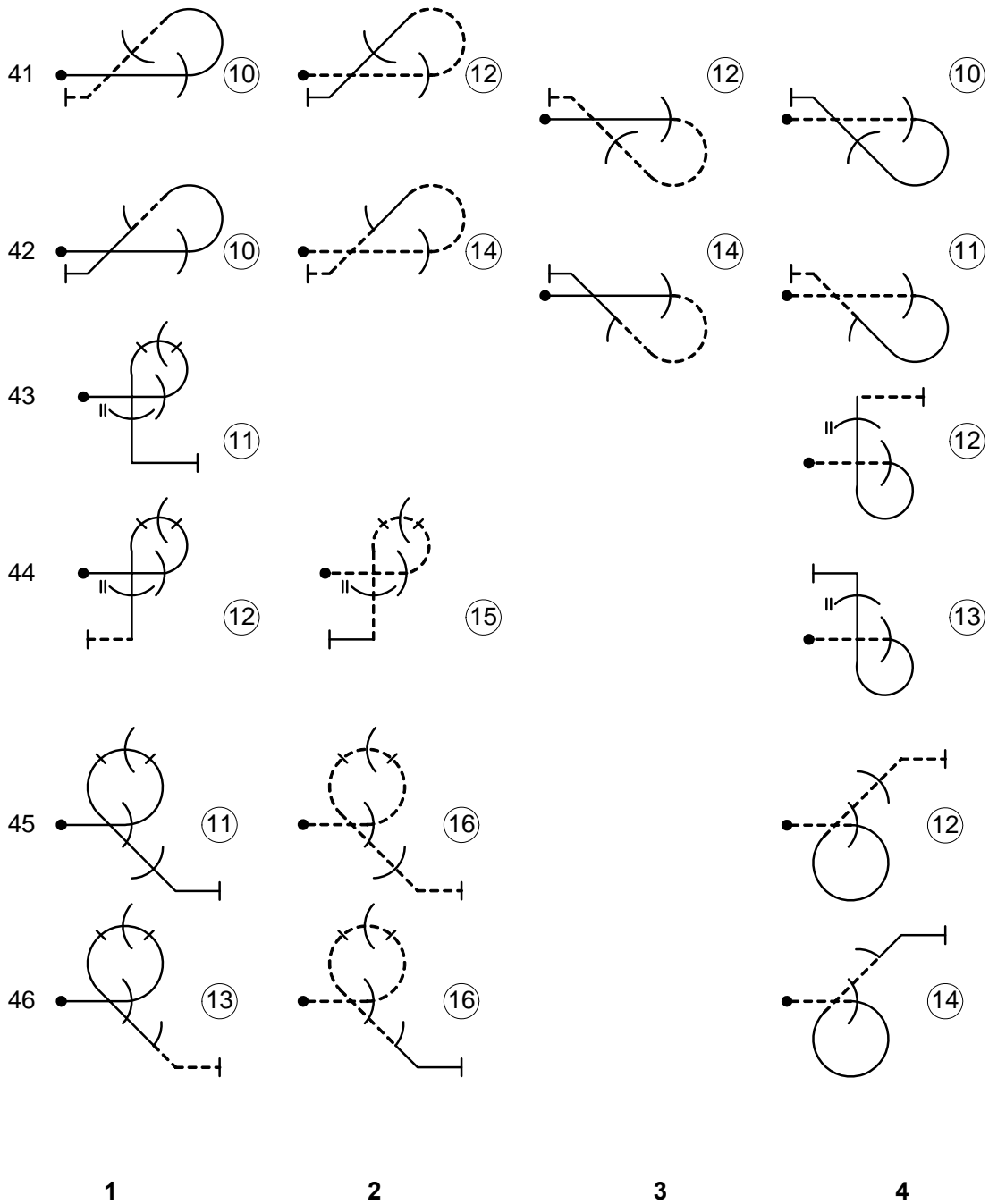

9.13.1.1. Flick rolls are not permitted on the horizontal entry lines of figures in columns a and 2 on this page, nor on vertical down lines of 8.43 or 8.44 after a hesitation roll in the loop.

9.13.1.2. No superslow rolls are permitted on the top of figures in columns 1 and 2 of 8.43 through 8.46.

9.13.1.3. No flick rolls are permitted on the down lines of figures 8.45.2 and 8.46.2.

9.13.1.4. No hesitation rolls are permitted on the top of 8.44.2, 8.45.2 and 8.46.2.

9.14. Family 8.47 To 8.52

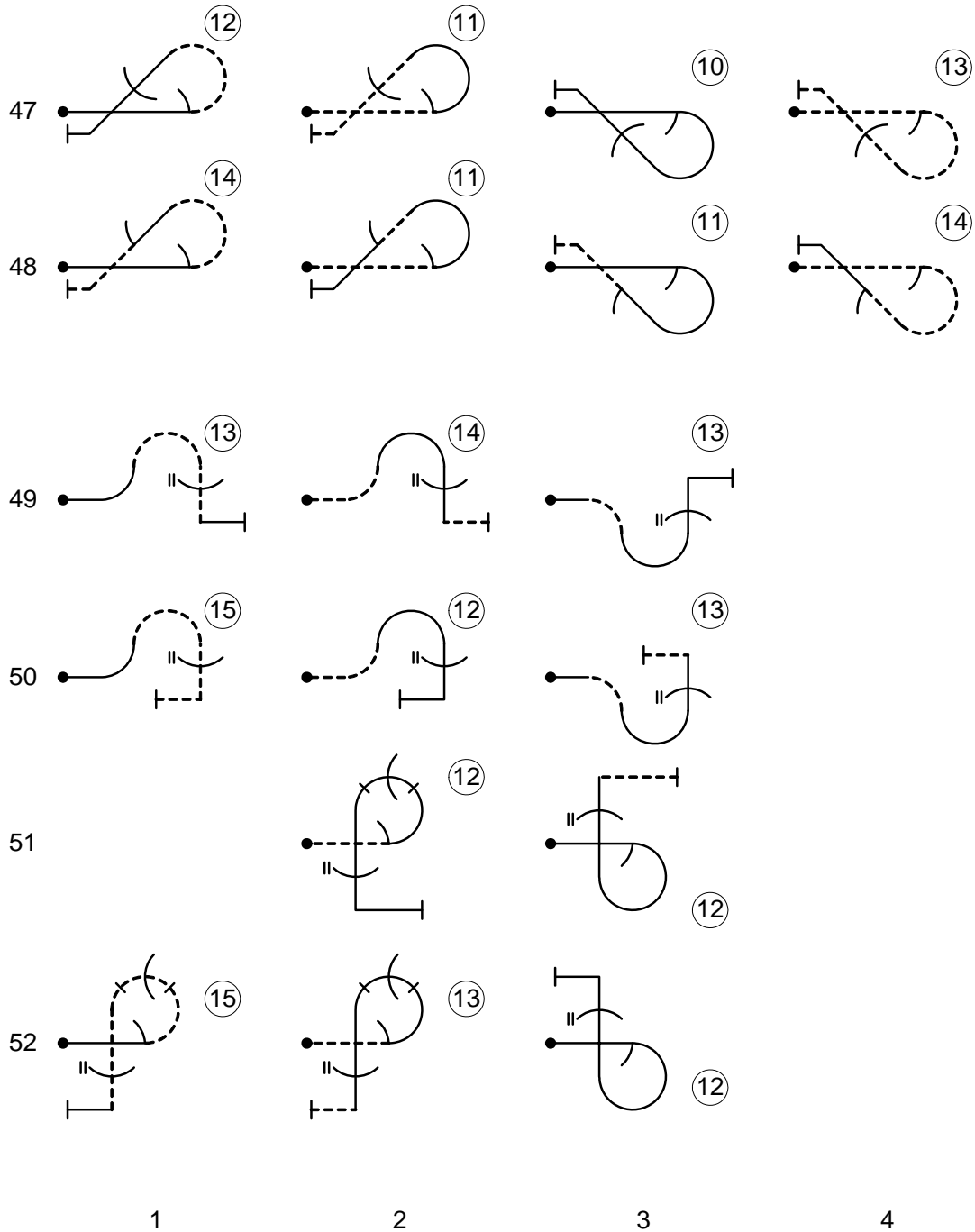

9.14.1.1. Flick rolls are not permitted on the horizontal entry lines of figures in columns 1 and 2 on this page, nor on vertical down lines of 8.51 and 8.52 after a hesitation roll in the loop.

9.14.1.2. No superslow rolls are permitted on top of figures 8.51.3, 8.52.1 and 8.52.2.

9.14.1.3. No hesitation rolls are permitted on top of figure 8.52.1.



9.15. Family 9.1, Continuous Rolls



9.1		$\frac{1}{4}$	$\frac{1}{2}$	$\frac{3}{4}$	1	$1\frac{1}{4}$	$1\frac{1}{2}$	$1\frac{3}{4}$	2
1		9							
2			9						
3			6		12		15		18
4			6		12				
5		3	6						
		1	2	3	4	5	6	7	8

9.16. Family 9.2, 2-Point Rolls

9.2					1	$1\frac{1}{2}$		2	
3					14				
		1	2	3	4	5	6	7	8

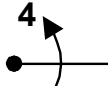

9.17. Family 9.4, 4-Point Rolls

9.4			$\frac{1}{2}$	$\frac{3}{4}$	1	$1\frac{1}{4}$	$1\frac{1}{2}$	$1\frac{3}{4}$	2
2			11						
3			8		17				
4			8						
		1	2	3	4	5	6	7	8

9.18. Family 9.8, 8-Point Rolls

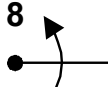



9.8		$\frac{1}{4}$	$\frac{1}{2}$	$\frac{3}{4}$	1	$1\frac{1}{4}$	$1\frac{1}{2}$	$1\frac{3}{4}$	2
3			11						
		1	2	3	4	5	6	7	8





9.19. Family 9.13, Super Slow Rolls

9.13			$\frac{1}{2}$		1		$1\frac{1}{2}$		2
3			8		16				
		1	2	3	4	5	6	7	8



9.20. Positive And Negative Flick Rolls

9.9			½	¾	1	1¼	1½	1¾	2
2			15						
3			12		16				
4			12		16				
5			12	14	16				
10			12	14	16				
		1	2	3	4	5	6	7	8

9.10			½	¾	1	1¼	1½	1¾	2
2			18						
3			15						
4			15		19				
5			15	17	19				
10			15	17	19				
		1	2	3	4	5	6	7	8

9.20.1.1.No inverted exit after more than ½ negative flick vertically down



9.21. Family 9.11 (Positive Spins)

			1	1¼	1½	1¾	2	
1		Upright Entry Line			5	6	7	
			4	5	6	7	8	

9.22. Family 9.12 (Negative Spins)

			1	1¼	1½	1¾	2	
1		Inverted Entry Line			7	8	9	
			4	5	6	7	8	



10. RULES FOR THE USE OF ELECTRONIC HEIGHT MEASURING DEVICES (HMDs)

10.1. Types of HMDs

10.1.1.1. There are currently two types of Height Measuring Devices approved by CIVA.

- a) The Huber Height Measuring Device (HHMD)
- b) The Meierhofer Height Measuring Device (MHMD)

10.2. Functions of HMDs

10.2.1. Overview

10.2.1.1. An onboard transmitter sends signals to the ground receiving equipment (at the Chief Judge's position) when the glider descends below the upper or lower height limits or the disqualification height. The ground equipment indicates the height and the identification of the transmitter on a display and emits an audio signal ("beep") whenever signals from one of the onboard transmitters are received.

10.2.1.2. MHMD

- a) If a PC is connected to the ground receiver, the actual height above ground will be indicated in real time. The received height data can also be recorded for later analysis.
- b) All height limits can be set individually whenever this becomes necessary due to terrain or other reasons.

10.2.1.3. In case of the **HHMD**, the onboard transmitters must be re-programmed, when non-standard height limits are to be used.

10.2.1.4. The HMD transmitter in the glider cockpit provides the following audio signals to the pilot:

- a) Functional checks at 100/200 m during tow (one "beep" each),
- b) Continuous signal ("beep-beep-beep") as long as the glider flies above the upper height limit,
- c) Descent below the upper height limit is indicated by the stop of the continuous signal,
- d) Descending below 200 m: one "beep" (HHMD),
- e) Descending below 100 m: one "beep" (HHMD),
- f) Descending below 200 m until reaching 100 m: continuous signal "beep-beep-beep" (MHMD)

10.2.1.5. If the glider climbs back above the respective height, the signal will be repeated every time it descends below that height again.



10.3. Technical Characteristics

10.3.1. Tolerances

10.3.1.1. The onboard transmitter will always send its signals according to the pre-programmed height limits. In the case of the HHMD, small tolerances are preset when programming the transmitters. This ensures that the signal for the upper height limit will be transmitted at an actual height slightly above the limit, whilst the signals for the lower limit and the disqualification height are transmitted slightly below the exact height. With the MHMD, the Chief Judge may select discrete tolerances for each height limit. These will then be taken into account when the height limits are set on the airborne transmitters.

10.3.1.2. The guaranteed overall tolerance of the HMD systems is considerably smaller than the tolerances of the conventional altimeters used in gliders. Pilots must further understand that unlike mechanical altimeters, the electronic pressure sensor in the HMD is not influenced by rate of descent or climb. This means that whilst the mechanical altimeter displays a significant lag during rapid changes of altitude (always indicating low in a climb and high in a descent), the HMD will transmit its signal instantaneously and exactly at the prescribed height.

10.4. Operating the HMDs

10.4.1.1. Whenever the HHMD is in use, it will be the primary reference to verify compliance with height limits and for decisions on penalties or disqualifications due to height infringements. HMD audio signals are recorded together with the video.

10.4.1.2. A person (Steward) assigned to the Chief Judge will monitor the HMD ground equipment and log every flight on a specific form, to keep track of proper functioning of the device and record height infringements. When the MHMD is in use, a PC should always be connected to the ground receiver in order to record the height data of all flights.

10.4.1.3. Installation, setting up, checking, and removal of the HMD onboard transmitters will be performed by a member of the Technical Commission or a person (Steward) specifically designated for this duty and supervised by the Technical Commission.

10.4.1.4. All participating gliders must have a mounting bracket for the onboard transmitter as specified in this Section. The pilot is responsible that the HMD transmitter is securely mounted inside the glider. Should the transmitter come loose during the flight due to improper mounting, this will not be accepted as a valid technical failure and a re-flight will not be allowed.

10.5. Pilot Procedures for the Use of the HMDs

10.5.1.1. With the upper height limit at 1200 m (750 m for split programmes), the towing height will be at least 50 m higher, in order to ensure proper functioning of the HMD.

10.5.1.2. Competitors may not start their programmes above 1200 m (or 750 m respectively). A penalty of 70 points is given if the first figure is initiated before the 1200 m (or 750 m) signal has been received or if the glider climbs above the upper height limit after starting the first figure. (The wing dip for the start of the programme may come above the upper height limit, as long as the first figure does not start prior to the HMD signal).

10.5.1.3. At the lower height limit, a penalty of 70 points is given for every figure flown, before or during which the 200 m signal is received.

10.5.1.4. If the 100 m signal is received before or during a figure, the competitor will be disqualified.

(Criteria for completion of figures: see paragraph 5.2.1.4)

10.6. Malfunction or Failure of the HMD

10.6.1.1. Whenever a competitor notices or assumes a malfunction of the Device (e.g. the audio signal does not stop below 1200 m), he/she may return for landing without starting the programme. After starting the programme, there is no justification for breaking off due to an assumed malfunction of the HMD.

10.6.1.2. As a safeguard against malfunctions of the Device, the judges will continue to record infringements of the lower height limit or the 100 m limit as specified in paragraph 4.2.4.4.

10.6.1.3. A failure of the link between the HMD and the official video recording equipment has no influence on the validity of the HMD measurements, as long as the normal functions of the HMD, as described above, are not degraded.

10.6.1.4. If the HMD system becomes unserviceable during the contest, procedures for towing and determining infringements of height limits for subsequent flights will be in accordance with the rules laid down in paragraph 4.2.4.4.

10.7. Mounting Brackets

10.7.1. MHMD

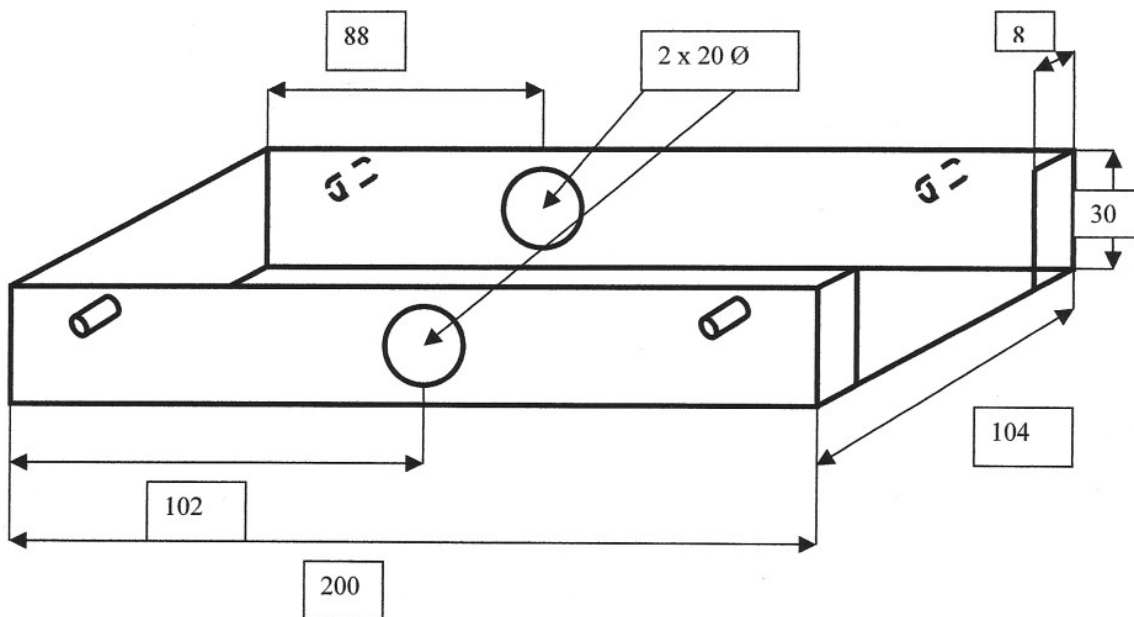

10.7.1.1. All dimensions are interior measurements in millimeters. The HMD transmitter should be fixed in the mounting by two rubber bands of sufficient strength. Dimensions of the MHMD transmitter are 195 x 100 x 40 mm. Mass is 535 g including batteries and antenna.

10.7.2. HHMD

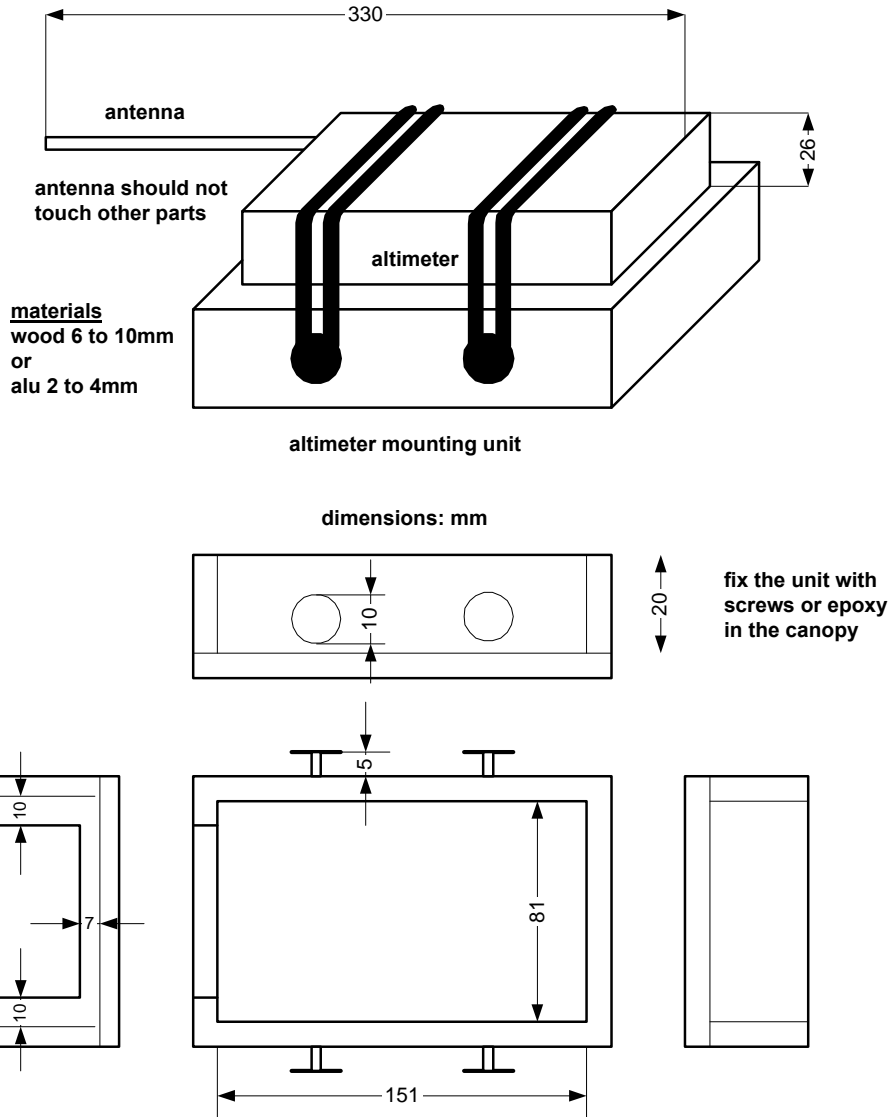

For any questions:
call or fax to PETER HUBER

e-mail: spc-hupe@eunet.at
fax: +43-7724-60784

10.7.3. Remarks

10.7.3.1. Any mounting should be strong enough and attached securely enough to withstand the g-forces likely to be encountered during aerobatics.

10.7.3.2. It is the pilot's responsibility to ensure that the HMD transmitter is securely mounted in the glider.



11. KNOWN COMPULSORY PROGRAMMES

11.1. Unlimited Known Programme

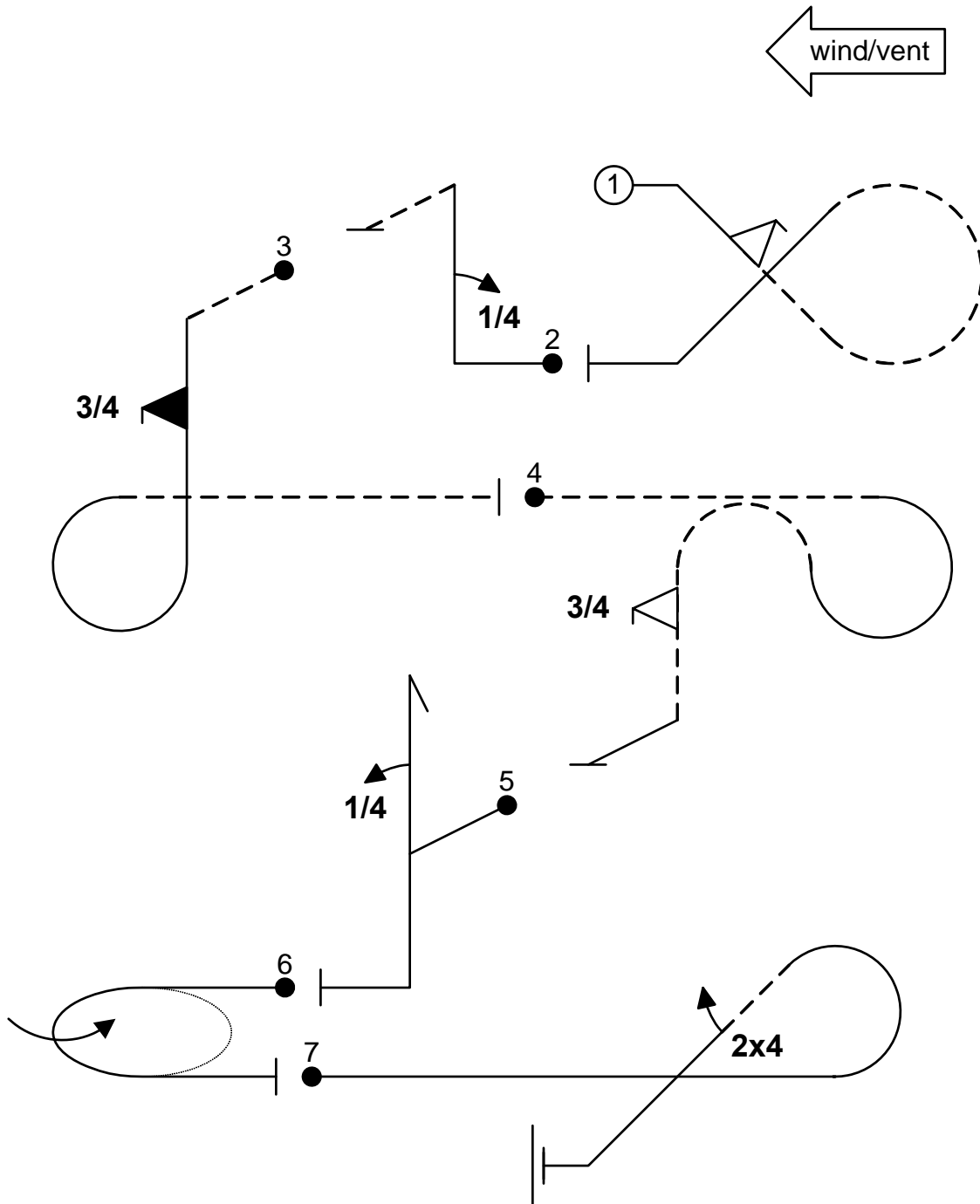



11.2. Advanced Known Programme

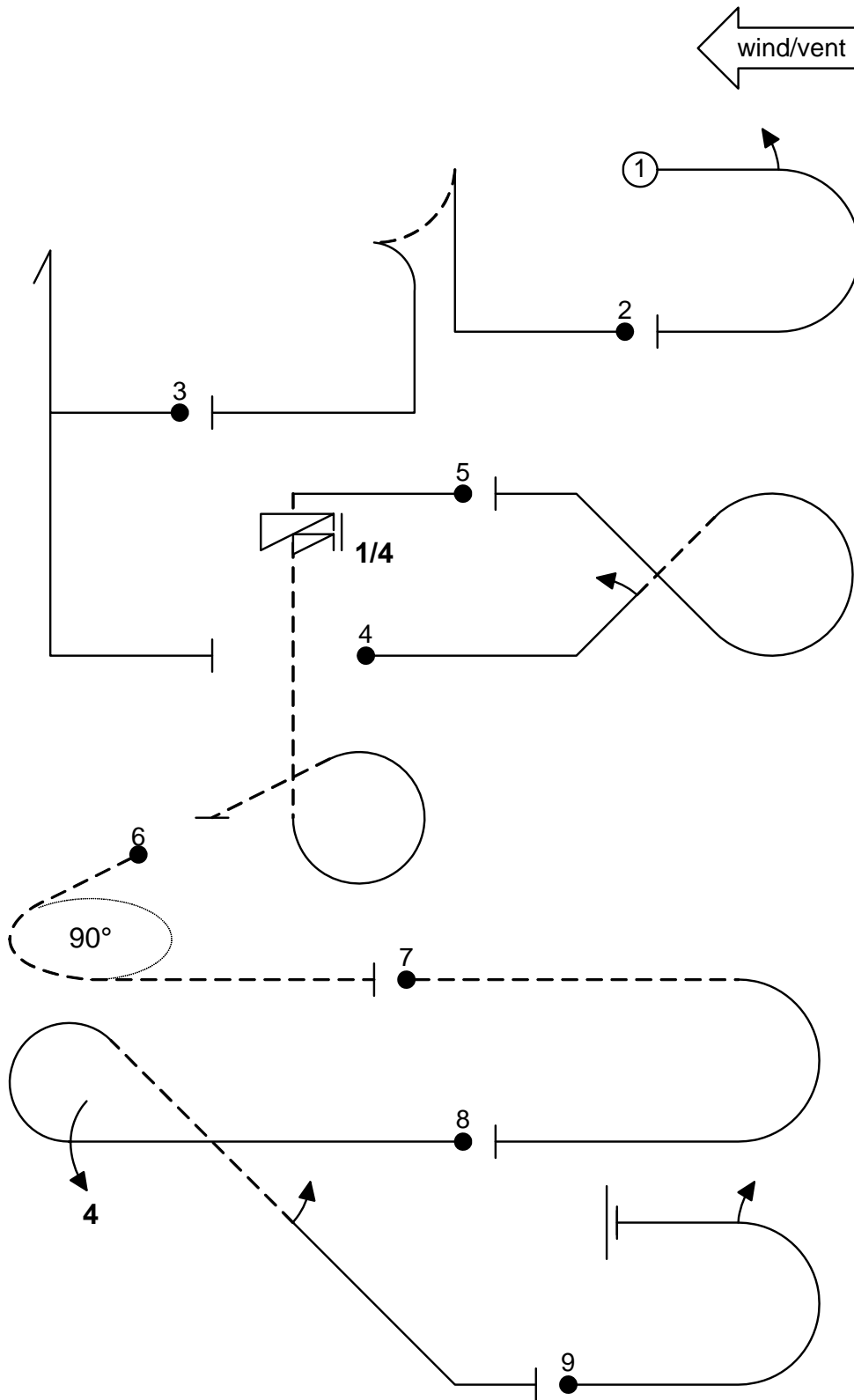



12. RECORD OF AMENDMENTS

Version Number	Date Issued
2006-1	1 February 2006
2007-1	1 January 2007
2008-1	1 March 2008
2008-2	1 May 2008
2009-1	1 January 2009
2010-1	1 February 2010
2010-2	22 February 2010 9.7.1.2; 9.8.1.2